



Gas Spring - Contents

About Gas Springs			1
Initial Force N 	Cylinder diameter mm 	Models 	
$F_{INIT} < 2500$	Ø 12 Ø 32	EP2 16, EP2 24, EPS2 24 R12, R15, R19 M2, MM2, MC3 X 170 MT 16, MT 24	2
$2500 \leq F_{INIT} < 5000$	Ø 25 Ø 38	CU 420 X 320, X 350, XG 350 TU 250, TM 250, TI 250, TMS 250 MT 300	3
$5000 \leq F_{INIT} < 7500$	Ø 38 Ø 45	CU 740 X 500, XG 500 K 500, TU 500 MT 500	4
$7500 \leq F_{INIT} < 10000$	Ø 45 Ø 75	X 750, XG 750, TL 750 K 750, KM 750 TU 750, TUS 750, LCF 750, TB 750, SL 750, SPC 750 MT 750	5
$10000 \leq F_{INIT} < 25000$	Ø 38 Ø 95	CU 1000, CU 1800 X 1000, XMS 1000, XG 1000, TX 1000, TL 1500, X 1500, XG 1500, X 2400, XG 2400, TX 2400 K 1500, TU 1500, TUS 1500, LCF 1500, TB 1500, SL 1500, SPC 1500 MT 1000	6
$25000 \leq F_{INIT} < 50000$	Ø 75 Ø 120	CU 2900, CU 4700 X 4200, XG 4200, TX 4200 TL 3000, TU 3000, TUS 3000, LCF 3000, TB 3000, SL 3000, SPC 3000	7
$50000 \leq F_{INIT} < 75000$	Ø 120 Ø 150	X 6600, XG 6600, TX 6600 TL 5000, TU 5000, TUS 5000, LCF 5000, TB 5000, SL 5000, SPC 5000	8
$75000 \leq F_{INIT} < 100000$	Ø 95 Ø 150	CU 7500 X 9500, TX 9500 TU 7500, TUS 7500, LCF 7500	9
$F_{INIT} \geq 100000$	Ø 120 Ø 195	CU 11800, CU 18300 TU 10000 X 20000	10

Volvo standard

Kaller is the Volvo standard for gas springs, hydraulic cams and roller cams. In the downloads here you find the Volvo part numbers for all Kaller parts that are Volvo standard.

- **GREEN**: Preference 1. The items that are "first choice" have the Volvo part numbers marked green.
- **YELLOW**: Preference 2. The items with yellow Volvo part numbers can be used if the green marked alternative is impossible to use in the specific case.
- **UNCOLOURED**: The items with uncoloured Volvo part numbers must not be used for new design, only for replacement in old dies.

Items that are not provided with Volvo part numbers can be used after confirmation from Volvo: please contact glarss16@volvocars.com or your technical contact person at Volvo.

About gas springs

GENERAL	Page 2.1/2
Main groups of gas springs	Page 2.1/2
Overview of models	Page 2.1/3
LCF (Low Contact Force) gas spring information	Page 2.1/4
Speed Control™ gas spring information	Page 2.1/4
USER INFORMATION	Page 2.1/5
Mounting instructions / Mounting of Gas Springs	Page 2.1/5
Stroke length	Page 2.1/6
Maximum charging pressure	Page 2.1/6
Operating temperature	Page 2.1/6
Recommended maximum strokes/minute	Page 2.1/6
Maximum piston rod velocity	Page 2.1/6
Service interval	Page 2.1/6
Service information	Page 2.1/6
CAD-files	Page 2.1/6

GENERAL

KALLER gas springs are designed to meet customer expectations for reliability, safety and service lifetime. The design, manufacture and testing of KALLER gas springs has been approved according to the European



Pressure Equipment Directive (97/23/EC).

The Pressure Equipment Directive (PED) replaces all previous European legislative laws governing the design, manufacture and testing of pressure vessels. Manufacturing is carried out, using the very latest production methods and equipment, at our modern facilities in Tranås, Sweden.

Strömsholmen AB, the designers and manufacturers of KALLER gas springs, has been ISO 9001 approved since 1994 and ISO 9000:2000 and PED (97/23/EC) approved since 2002 and is the World's first and leading manufacturer of nitrogen gas springs for the metal stamping industry.

KALLER World-wide guarantee

The World-wide service life guarantee for KALLER products is valid for specified number of strokes within 2 years after date of purchase. The product should be used according to the specifications and recommendations given in our User Guides, product and service literature. In case of misuse or mechanical damage the guarantee is no longer valid.

Gas Springs:

1 million strokes (max 100'000 stroke meters).

Controllable Gas Springs, Flex Cam and other products:

500'000 strokes.

Main groups of gas springs

KALLER gas springs can be split into two main groups, namely Piston Rod Sealed and Bore Sealed. The two basic designs can be seen below:

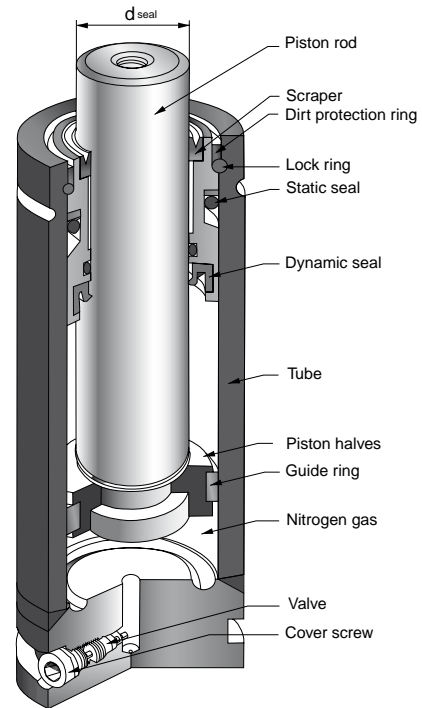

Piston Rod Sealed gas spring

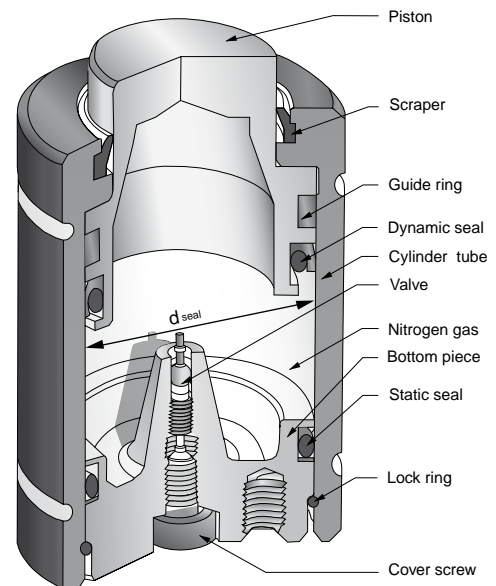

Bore Sealed gas spring

Overview of models

The following is an overview of our Tool & Die family of gas springs:

EP Series:

Non-repairable. These Ejector Pin gas springs are color coded and fully adjustable with either an M16 or M24 threaded body.

Forces: 57 N to 1700 N
94 lbf to 380 lbf
Strokes lengths: 10 mm to 125 mm
Max. strokes/min.: ~100 (at 20°C)

R Series:

Non-repairable, colour coded and fully adjustable gas springs with Ø 12, Ø 15 and Ø 19 mm outer body diameters.

Forces: 130 N to 900 N
110 lbf - 200 lbf
Strokes lengths: 7 mm to 125 mm
Max. strokes/min.: ~100-150 (at 20°C)

Mini Series:

Colour coded and fully adjustable gas springs with Ø 25, Ø 32 and M28x1.5 small outer body diameters.

Forces: 280 N to 2000 N
63 lbf to 450 lbf
Strokes lengths: 10 mm to 125 mm
Max. strokes/min.: ~80-100 (at 20°C)

CU Series:

These Super-Compact gas springs are bore sealed, providing a high amount of force while having small outer body diameters.

Forces: 4250 N to 183000 N
960 lbf to 41140 lbf
Strokes lengths: 6 mm to 50 mm
Max. strokes/min.: ~100 (at 20°C)

Power Line - X Series:

The World's shortest and strongest Rod Sealed gas spring with tapped base mounting holes and side charging port for hose system connection.

Forces: 1700 N to 200000 N
380 lbf to 44960 lbf
Strokes lengths: 7 mm to 125 mm
Max. strokes/min.: ~15-100 (at 20°C)

Power Line - XG Series:

our short and most powerful Rod Sealed gas springs offer a great deal of force in a very small space.

Forces: 3600 N to 663000 N
810 lbf to 14905 lbf
Strokes lengths: 10 mm to 125 mm
Max. strokes/min.: ~15-100 (at 20°C)

Power Line - TX Series:

A crossover between our standard TU series and our Power Line X series.

Forces: 92000 N to 950000 N
2075 lbf to 21400 lbf
Strokes: 13 mm to 300 mm
Max. strokes/min.: ~15-100 (at 20°C)

TL Series:

KALLER's TL series ranges from model sizes 750 to 5000, with the same features and technology as the TU series.

Forces: 75000 N to 50000 N
1641 lbf to 11190 lbf
Stroke lengths: 25 mm to 300 mm
Max. strokes/min.: ~15-40 (at 20°C)

TU Series:

KALLER's standard series and the World's first range of gas spring. Dimensions correspond to the ISO 11901 standard for gas springs.

Forces: 2500 N to 100000 N
600 lbf to 23830 lbf
Stroke lengths: 10 mm to 300 mm
Max. strokes/min.: ~15-40 (at 20°C)

TUS Series:

KALLER's TUS series, designed for increasing press speeds. Dimensions correspond to the ISO 11901 standard for gas springs.

Forces: 75000 N to 750000 N
1665 lbf to 16860 lbf
Stroke lengths: 25 mm to 300 mm
Max. strokes/min.: ~15-40 (at 20°C)

K Series:

Short height version of the TU Series with tapped base mounting holes and side charging port for hose system connection.

Forces: 5000 N to 15000 N
1124 lbf to 3372 lbf
Strokes lengths: 6 mm to 125 mm
Max. strokes/min.: ~30 (at 20°C)

MT Series

Mould Temp gas springs are compact and powerful piston rod sealed gas springs, which can be used in spring temperatures up to 120°C.

Forces: 420 N to 10000 N
94 lbf to 2090 lbf
Strokes lengths: 10 mm to 80 mm
Max. strokes/min.: ~20 (up to 80°C)

LCF (Low Contact Force) gas spring information

The LCF series is the future generation of nitrogen gas springs. This innovative series is engineered to address the major problems facing metal stampers today: excessive shock loads, high noise levels and extreme pad/blank-holder bounce, all factors that lead to high press maintenance costs and noise pollution. The LCF series reduces shock load by as much as 50% compared to standard gas springs. They deliver a gradual force build-up and smooth acceleration so there's less impact on gear and bearings and less wear on drive components.

The payoff is reduced press maintenance.

The LCF series lowers noise levels significantly, with a higher reduction in sound pressure level compared to standard gas springs. Its lesser impact force results in these lower noise levels and makes these springs a cost effective alternative to building noise enclosures. *The payoff is a quieter, safer and healthier working environment.*

The LCF series decreases pad/blank-holder bounce, allowing improved part transfer efficiency, increased production rates and reduced scrap. A gradual force increase and return results in smoother pad/blank-holder operation.

The payoff is higher production rates.

Because LCF gas springs mount directly to the die and are independent from the press, all benefits travel with the tool.

Standard features:

- 100% interchangeable with standard, ISO gas springs (i.e. our TU Series)
- Retrofits in existing dies
- Charged and rebuilt like standard gas springs
- Drop in, flange mount, or base plate mounting
- Can be hoses together
- Can be incorporated into press cushions

Speed Control™ - SPC gas spring information

Speed Control™ gas springs have been designed to reduce or eliminate blank holder bounce and are the latest addition to our range of Problem Solving Kaller products.

Speed Control™ gas springs work by slowing down the speed that the blank holder is travelling at just before it reaches its start position.

This is achieved by damping the Speed Control's piston rod return speed to 0.4 m/s for the last 30 mm of piston rod travel.

Blank holder bounce often occurs as a result of an excessive press stroke return speed, commonly associated with special link-drive presses.

The height of the blank holder lift depends on the speed that the blank holder is travelling at when its supporting gas springs reach their fully extended positions. At this point, the inertia of the blank holder causes it to lift up from its supporting gas springs.

If we assume that at this separation point the only force acting on the blank holder is gravity, then we can calculate the theoretical height the blank holder will lift, at various separation speeds:

Separation Speed [m/s]	Theoretical Lift [mm]
0.5	13
0.8	33
1.0	50
1.6	130

However in reality, there are other factors affecting the blank holder that can either increase or decrease these theoretical lift heights.

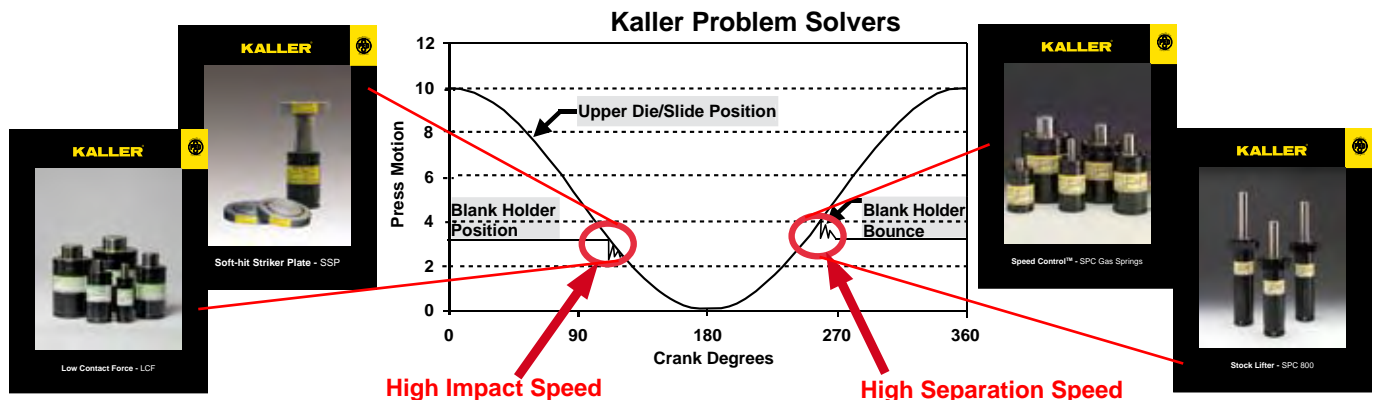

USER INFORMATION

Mounting of Gas Springs

1

Mounting Instructions

To achieve the best possible service-life and safety from the gas spring, the instructions below must be followed. The gas spring is intended for use in tool and machine applications.

- Secure the gas spring to the tool/machine whenever possible, using the threaded hole(s) in the base of the gas spring or a suitable flange.
- The threaded hole in the piston rod top should not be used for mounting purposes. It is only to be used when servicing the gas spring.
- Do not use the gas spring in such a way that the piston rod is released freely from its compressed position, as this could cause internal damage to the gas spring.
- The maximum allowed stroke speed is from 0.5 to 2.0 m/s, depending on model (see catalogue).
- Make sure the gas spring is mounted parallel to the direction of the compression stroke.
- Ensure the contact surface of the piston rod top is perpendicular to the direction of the compression stroke and is sufficiently hardened.
- The gas spring should not be subjected to side loads.
- Protect the piston rod against mechanical damage and contact with fluids.
- Ensure the entire contact surface of the piston rod/piston is used.

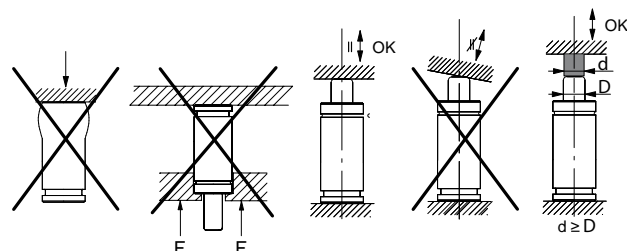
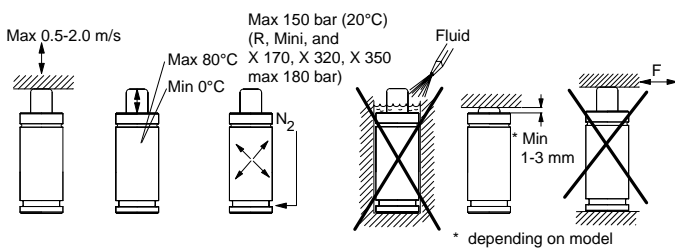

When mounting the gas spring in the tool/machine certain specifications must be followed in order to secure that the mount/flange does not come loose:

- Screws shall have a free length (clamping length) of 2 to 4 x thread diameter and a thread depth of at least 1 x thread diameter in steel and 1.5 x diameter in cast iron.
- If the free length cannot be achieved in any other way, the screw holes shall be countersunk.
- Always use a torque wrench to apply the appropriate torque.

Thread	Torque (screw class 8.8 acc. to ISO 898-1)
M6	10 Nm
M8	24 Nm
M10	45 Nm
M12	80 Nm
M16	160-200 Nm

- Make sure the bottom of the spring is always supported.

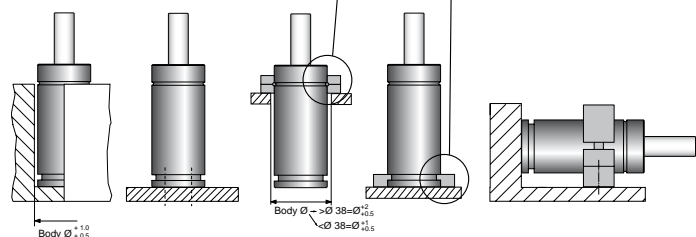
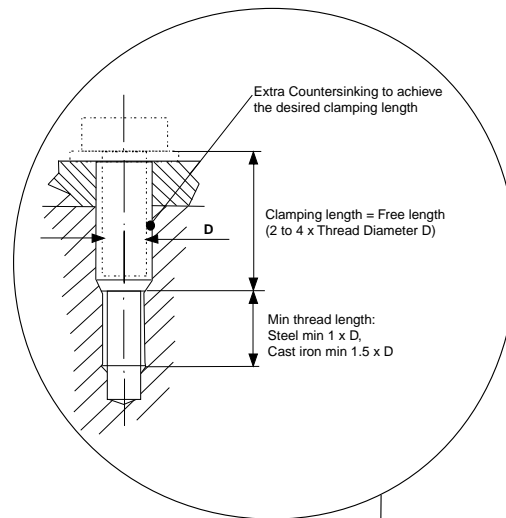

Stroke length

The nominal stroke (defined as S in the catalogue tables) may be utilised fully in all KALLER gas springs. However the recommendation is not to use the full stroke in normal operation. This is to prevent the spring from being "over-stroked" as a result of changes to the tool or mis-happenings in the tool.

We do not recommend the last 5 mm or 10 % of the nominal stroke be utilised.

Maximum charging pressure

The maximum charging pressure (at 20°C) stated for the different gas springs may not be exceeded as it may affect the safety of the product.

Operating temperature

Exceeding the gas spring's recommended max. operating temperature will shorten the service-life of the gas spring.

Recommended maximum strokes/minute

The values given for each gas spring in the catalogue are valid for "normal" applications in press tools. The lower limits given are valid for the longer stroke lengths and the higher values for short stroke springs. These values are based on a fully utilised stroke. If only a portion of the stroke is used the number of strokes per minute could be increased.

For further information contact your local distributor.

Maximum piston rod velocity

The maximum piston rod velocity is not to be exceeded because it may infringe on safety, as well as the performance of the gas spring.

Service interval

If correctly installed and used, the following minimum service-interval of the KALLER Gas Springs, except models TB and MT, is recommended.

Stroke lengths up to and including 50 mm:

after 1 million strokes.

Stroke lengths above 50 mm:

after 100 000 stroke meters.

The number of stroke meters is calculated as:

$$\text{Used stroke (in meters)} \times 2 \times \text{number of strokes.}$$

Service information

All KALLER gas springs can be serviced except the following models EP2 16, EP2 24, EP2S 24, R12, R15, R19, CU 420, X 170, X 320, X 2400-016 and MT 16, MT 24 series.

Repair Kits and Tool Kits are available for all other models. Service instructions are included in the Repair Kits.

Caution! Only specially trained personnel with good knowledge about the products should carry out the maintenance. Mistakes made during assembly and charging may infringe on safety and/or have a detrimental effect on the service-life of the product.

Your local distributor can help you with training. (Service-video in VHS-PAL, CD-ROM and DVD are also available).

CAD-files

To make it easier for tool designers to design in our gas springs, KALLER products are available as both 2D and 3D CAD files/models. These are available for download from our web-site (www.kaller.com) or can be ordered from your local distributor on CD.

Page intentionally left blank

Overview - $F_{INIT} \leq 2500$

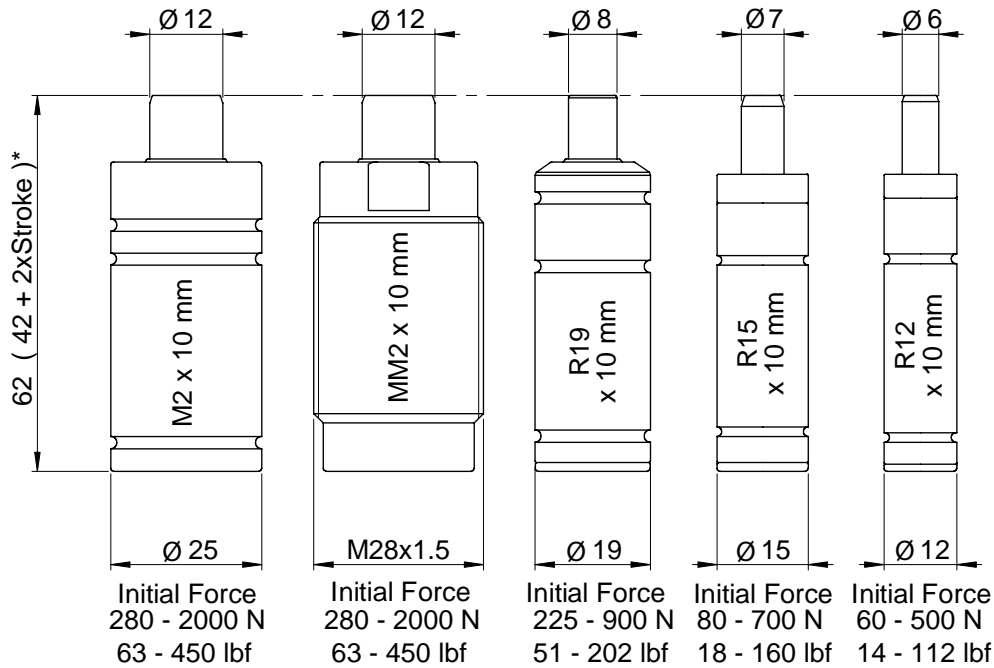







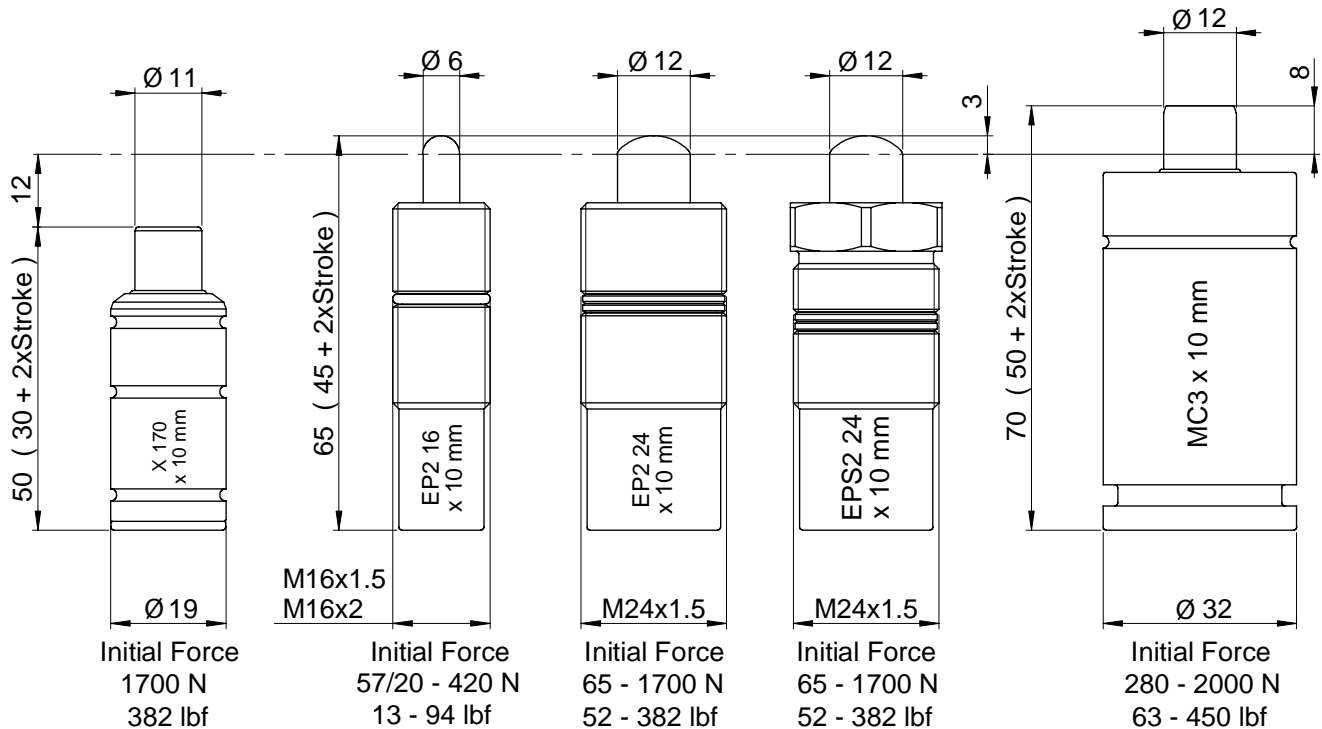

* Total length for M2 stroke length 63.5 mm and longer is $45 + (2 \times \text{Stroke})$

* Total length for R12, R15 and R19 stroke length 63.5 mm and longer is $45 + (2 \times \text{Stroke})$

* Total length for X 170 stroke length 75 mm and longer is $35 + (2 \times \text{Stroke})$



$F_{INIT} < 2500$

EP2 16		Page 2.2/2
EP2 24		Page 2.2/3
EPS2 24		Page 2.2/4
R12		Page 2.2/6
R15		Page 2.2/8
R19		Page 2.2/10
M2		Page 2.2/12
MM2		Page 2.2/14
MC3		Page 2.2/16
X 170		Page 2.2/18



2

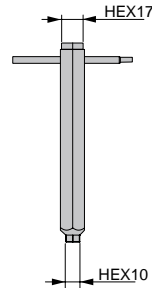
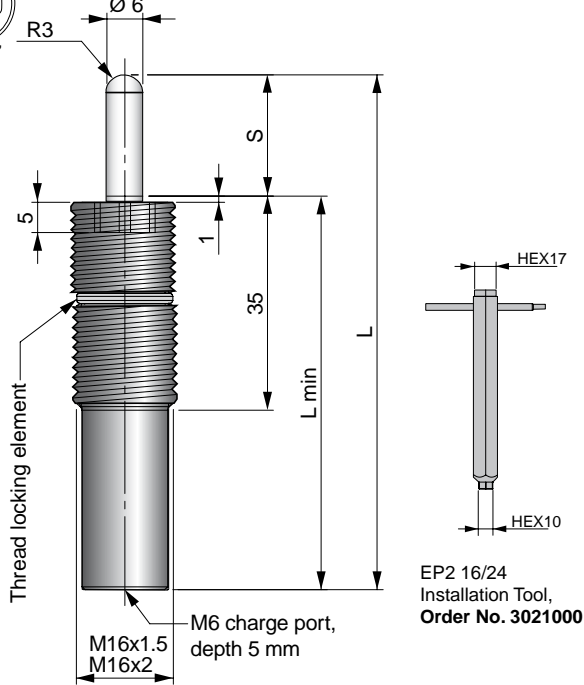

EP2 16/24 Installation Tool, Order No. 3021000

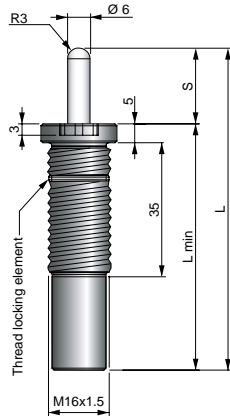
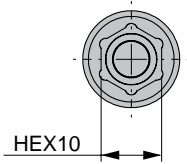

Also available with shoulder as per GM-Standard. Contact your local distributor or Strömsholmen AB for more information.

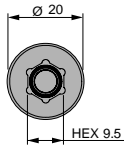

EP2 16 gas springs (Ejector Pin with an M16 thread) are available in M16x1.5 and M16x2 thread size.

In each thread size, five models are available. Six preset models (Orange, Purple, Green, Blue, Red & Yellow) and one adjustable model (Black), whose pre-charging pressure is 5-10 bar, intended for the customer to adjust the gas charge pressure.

They are all color-coded to help identify the force rating and can be adjusted and re-charged to meet individual force requirements.

How to order

EP2 16x1.5 - 10 - Blue

Model: Force: Orange, Purple, Green, Blue, Red, Yellow, Black

Thread: x1.5 = M16x1.5, x2 = M16x2, Stroke Length (mm) (10, 20, 30, 40, 50, 60, 70, 80, 100, 125)

Model	Initial Force at +20°C		Colour	Charging pressure (bar)	End force at +20°C, at full stroke	
	in N	in lbf			in N	in lbf
EP2 16x2	Being phased out!		Orange	6	32	7
EP2 16x2	40		Purple	12	64	14
EP2 16x1.5/x2	57	13	Green	20	91	20
EP2 16x1.5/x2	110	25	Blue	40	180	40
EP2 16x1.5/x2	210	47	Red	75	335	100
EP2 16x1.5/x2	420	95	Yellow	150	670	150
EP2 16x1.5/x2 XX*	40-420	9-95	Black	12-150	32-670	20-150

* Force to be set by the customer. Delivered with a pre-charge of 5-10 bar.

S Stroke	L ±0.25	L min	Gas vol. (l)	Weight (kg)
10	65	55	0.002	0.06
20	85	65	0.003	0.07
30	105	75	0.003	0.07
40	125	85	0.004	0.08
50	145	95	0.005	0.08
60	165	105	0.006	0.09
70	185	115	0.007	0.10
80	205	125	0.008	0.11
100	245	145	0.009	0.11
125	295	170	0.012	0.13

Basic Information

- For general information see "About gas springs", 2.1
- Pressure medium Nitrogen
- Max. charging pressure 150 bar
- Min. charging pressure 12 bar
- Operating temperature 0 to +80°C
- Force increase by temperature ± 0.3%/°C
- Recommended max strokes/min ~ 100 (at 20°C)
- Max piston rod velocity 1.6 m/s
- Rod surface..... Nitrided
- Tube surface Black Oxide
- Repair kit..... Non-repairable

Mounting Possibilities

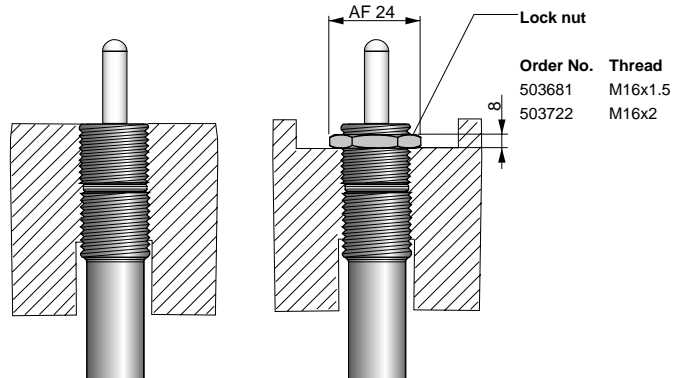

Order No.	Thread
503681	M16x1.5
503722	M16x2

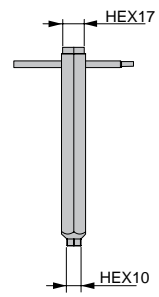
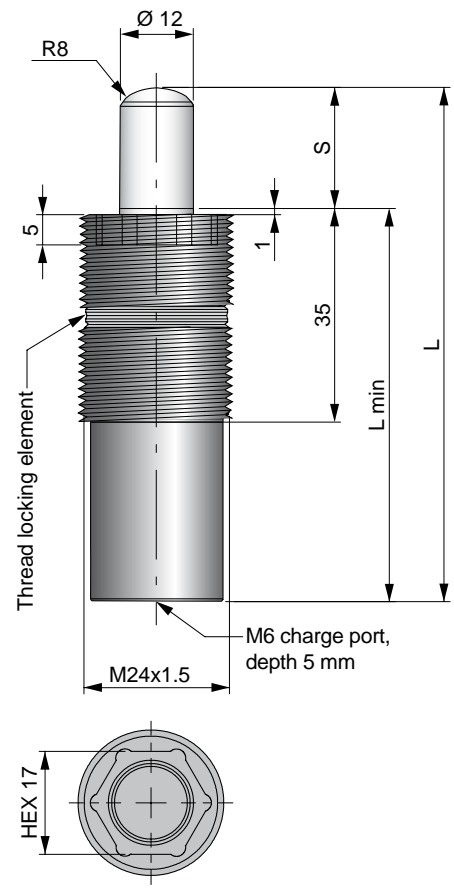

EP2 16/24 Installation Tool, Order No. 3021000

How to order

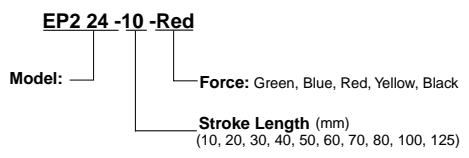

EP2 24 (Ejector Pin with an M24 thread). It is available with four pre-set models. Each model is color-coded for easy identification of force rating. If needed, these models can be re-charged or adjusted to meet individual force requirements.

Also available is a model (black) which is delivered with a pre-charge of 5 to 10 bar, intended to be adjusted to the desired force.

Model	Initial Force at +20°C		Colour	Charging pressure (bar)	End force at + 20°C, at full stroke	
	in N	in lbf			in N	in lbf
EP2 24	230	52	Green	20	390	90
EP2 24	450	101	Blue	40	800	180
EP2 24	850	191	Red	75	1500	340
EP2 24	1700	382	Yellow	150	2900	650
EP2 24 XX*	65-1700	52-382	Black	6-150	110-2900	25-650

* Force to be set by the customer. Delivered with a pre-charge of 5-10 bar.

S Stroke	L ±0.25	L min	Gas vol. (l)	Weight (kg)
10	65	55	0.003	0.13
20	85	65	0.006	0.15
30	105	75	0.008	0.17
40	125	85	0.011	0.19
50	145	95	0.012	0.21
60	165	105	0.014	0.23
70	185	115	0.017	0.25
80	205	125	0.019	0.27
100	245	145	0.024	0.31
125	295	170	0.030	0.35

Basic Information | **Mounting Possibilities**

For general information see "About gas springs", 2.1
 Pressure medium Nitrogen
 Max. charging pressure 150 bar
 Min. charging pressure 6 bar
 Operating temperature 0 to +80°C
 Force increase by temperature ± 0.3%/°C
 Recommended max strokes/min ~ 30-80 (at 20°C)
 Max piston rod velocity 1.6 m/s

Rod surface..... Nitrided
 Tube surface Nitrided
 Repair kit..... Non-repairable

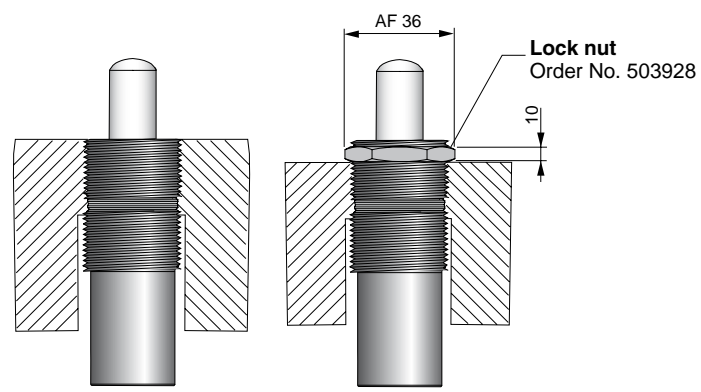

We reserve the right to add, delete or modify components without notification.

All dimensions are stated in mm. All dimensions are nominal unless tolerance is stated.

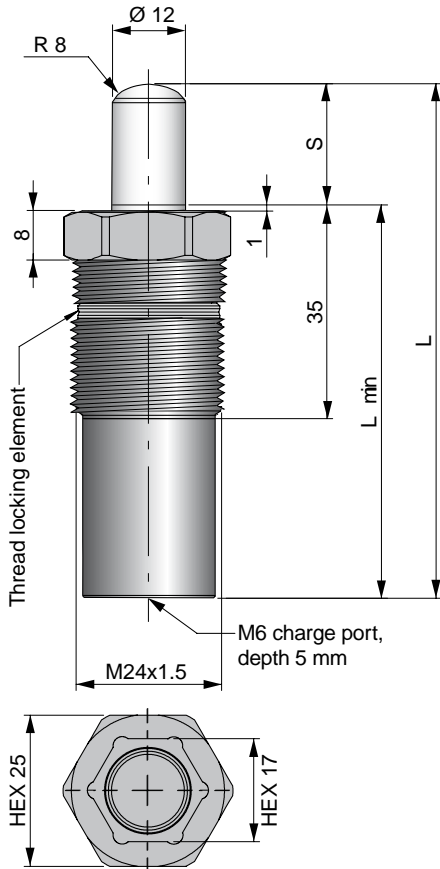

EPS2 24 (Ejector Pin Special with an M24 thread). It is available with six pre-set models. Each model is color-coded for easy identification of force rating. If needed, these models can be re-charged or adjusted to meet individual force requirements.

Also available is a model (black) which is delivered with a pre-charge of 5 to 10 bar, intended to be adjusted to the desired force.

Model	Initial Force at +20°C		Colour	Charging pressure (bar)	End force at + 20°C, at full stroke	
	in N	in lbf			in N	in lbf
EPS2 24	65		Orange	6	110	25
EPS2 24	110		Purple	10	190	45
EPS2 24	230	52	Green	20	390	90
EPS2 24	450	101	Blue	40	800	180
EPS2 24	850	191	Red	75	1500	340
EPS2 24	1700	382	Yellow	150	2900	650
EPS2 24 XX*	65-1700	52-382	Black	6-150	25-650	110-2900

* Force to be set by the customer. Delivered with a pre-charge of 5-10 bar.

S Stroke	L ±0.25	L min	Gas vol. (l)	Weight (kg)
10	65	55	0.005	0.14
16	77	61	0.006	0.15
20	85	65	0.007	0.16
25	95	70	0.008	0.17
30	105	75	0.010	0.18
38	121	83	0.011	0.19
40	125	85	0.012	0.20
50	145	95	0.014	0.21
60	165	105	0.017	0.23
70	185	115	0.019	0.25
80	205	125	0.022	0.27
100	245	145	0.026	0.31
125	295	170	0.032	0.36

How to order

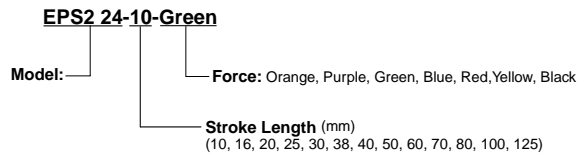

Basic Information

- For general information see "About gas springs", 2.1
- Pressure medium Nitrogen
- Max. charging pressure 150 bar
- Min. charging pressure 6 bar
- Operating temperature 0 to +80°C
- Force increase by temperature ± 0.3%/°C
- Recommended max strokes/min ~ 30-80 (at 20°C)
- Max piston rod velocity 1.6 m/s
- Rod surface..... Nitrided
- Tube surface Nitrided
- Repair kit..... Non-repairable

Mounting Possibilities

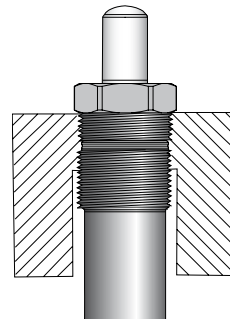

Page intentionally left blank

2

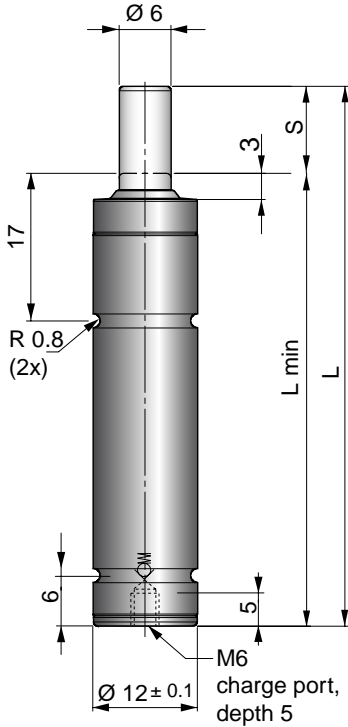

The R series get their name from the fact their tube is roll formed and therefore permanently closed, making them non-repairable.

R series springs are available with Ø 12, Ø 15, and Ø 19 mm tube diameters and with stroke lengths up to 125 mm.

There are 4 color-coded models, whose forces are preset. An adjustable model (black) is also available, that can be ordered to a specific charge pressure or adjusted by customers with the appropriate charging equipment and training.

How to order

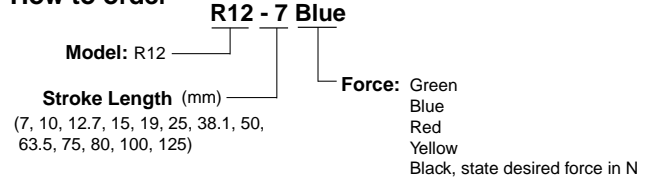

Model	Force in N at +20°C	Colour	Charging pressure [bar]
	Initial		
R12 13	130	Green	45
R12 25	250	Blue	90
R12 38	380	Red	135
R12 50	500	Yellow	180
R12 XX*	60-500	Black	20-180

*Force to be set by the end user. Delivered with a pre-charge of 5-10 bar.

S Stroke	End force in N at + 20°C*				L ±0.25	L min	Gas vol. [l]	Weight [kg]
	R12 13	R12 25	R12 38	R12 50				
7	149	299	448	597	56	49	0.001	0.03
10	158	317	475	634	62	52	0.001	0.03
12.7	164	329	493	657	67.4	54.7	0.001	0.03
15	168	335	503	670	72	57	0.002	0.03
19	172	344	517	689	80	61	0.002	0.04
25	177	354	530	707	92	67	0.002	0.04
38.1**	183	365	548	730	118	80	0.003	0.04
50**	185	371	556	742	142	92	0.004	0.05
63.5**	197	395	592	789	172	108.5	0.005	0.06
75**	197	394	591	788	195	120	0.006	0.06
80**	207	414	620	827	205	122	0.006	0.07
100**	204	409	613	817	245	145	0.008	0.07
125**	202	405	607	810	295	170	0.010	0.09

Basic Information

- For general information see "About gas springs" 2.1
- Pressure medium Nitrogen
- Max. charging pressure 180 bar (at 20°C)
- Min. charging pressure 20 bar (at 20°C)
- Operating temperature 0 to +80°C
- Force increase by temperature ±0.3%/°C
- Recommended max strokes/min ~40-100 (at 20°C)
- Max piston rod velocity 1.6 m/s

- Rod surface..... Nitrided
- Tube surface Black oxide
- Repair Kit Non-repairable

Mounting Possibilities

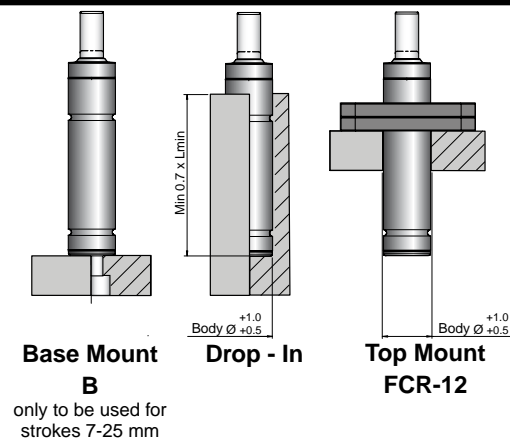

only to be used for strokes 7-25 mm

FCR-12

Order No: FCR-12

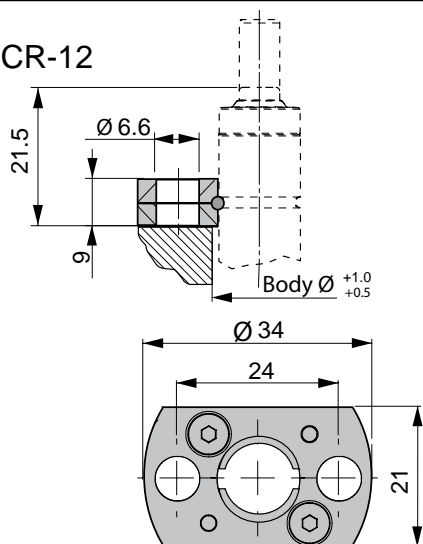

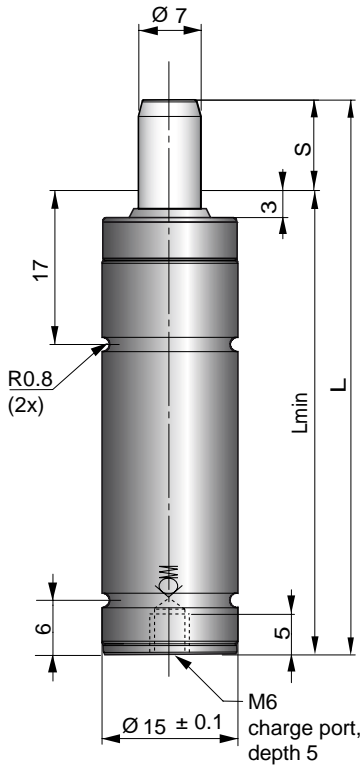

The R series get their name from the fact their tube is roll formed and therefore permanently closed, making them non-repairable.

R series springs are available with Ø 12, Ø 15, and Ø 19 mm tube diameters and with stroke lengths up to 125 mm.

There are 4 color-coded models, whose forces are preset. An adjustable model (black) is also available, that can be ordered to a specific charge pressure or adjusted by customers with the appropriate charging equipment and training.

How to order

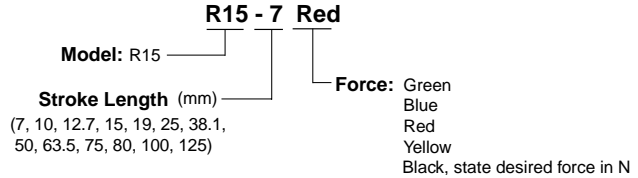

Model	Force in N at +20°C	Colour	Charging pressure (bar)
	Initial		
R15 18	180	Green	45
R15 35	350	Blue	90
R15 50	500	Red	135
R15 70	700	Yellow	180
R15 XX*	80-700	Black	20-180

S Stroke	End force in N at + 20°C*				L ±0.25	L min	Gas vol. (l)	Weight (kg)
	R15 18	R15 35	R15 50	R15 70				
7	216	432	648	865	56	49	0.001	0.05
10	224	447	671	895	62	52	0.001	0.05
12.7	228	457	685	914	68	55	0.001	0.05
15	232	463	695	927	72	57	0.002	0.05
19	236	471	707	943	80	61	0.002	0.05
25	240	480	720	961	92	67	0.002	0.06
38.1**	258	516	774	1032	118	80.1	0.003	0.07
50**	258	516	774	1033	142	92	0.004	0.08
63.5**	273	546	819	1092	172	108.5	0.005	0.09
75**	270	541	811	1082	195	120	0.006	0.10
80**	270	539	809	1079	205	125	0.006	0.11
100**	267	534	802	1069	245	145	0.008	0.12
125**	265	531	796	1062	295	170	0.010	0.14

*= at full stroke.

**Force to be set by the end user. Delivered with a pre-charge of 5-10 bar.

Basic Information

For more information, see "About gas springs" 2.1
 Pressure mediumNitrogen
 Max. charging pressure 180 bar
 Min. charging pressure20 bar
 Operating temperature0 to +80°C
 Force increase by temperature.....±0.3%/°C
 Recommended max strokes/min~100-150 (at 20°C)
 Max piston rod velocity 1.6 m/s

Rod surfaceNitrided
 Tube surfaceBlack oxide
 Repair KitNon-repairable

Mounting Possibilities

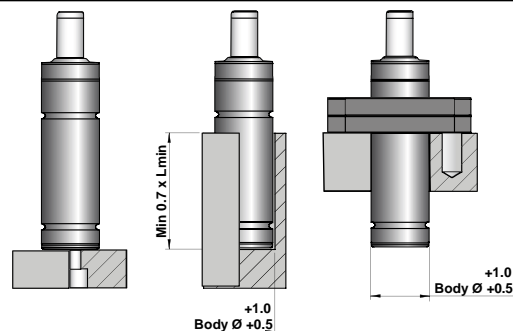

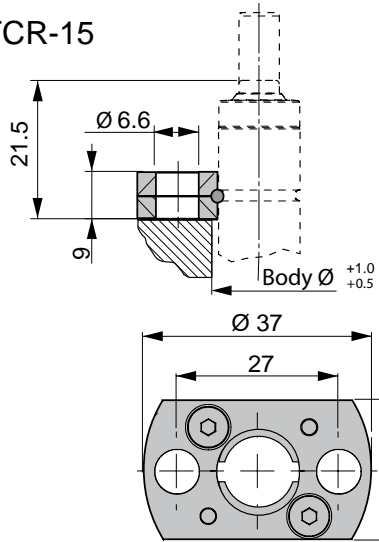
FCR-15
Order No: FCR-15

R19

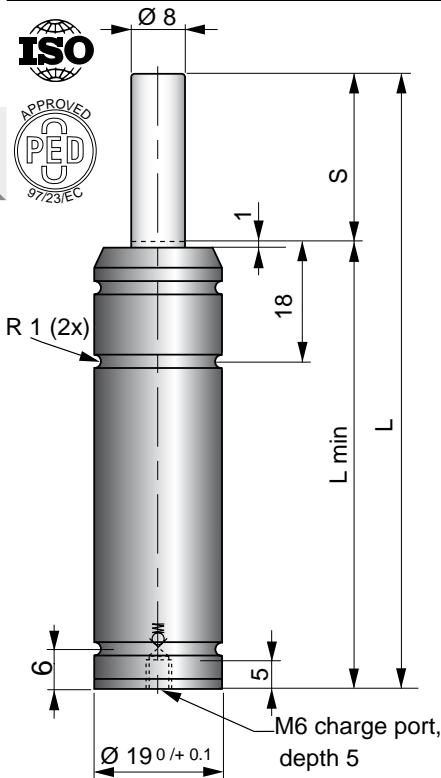

TM sleeve, M24 x 1.5
Order No. 3020615-M24

TI sleeve, UNC 1"- 8
Order No. 3020615-UNC1

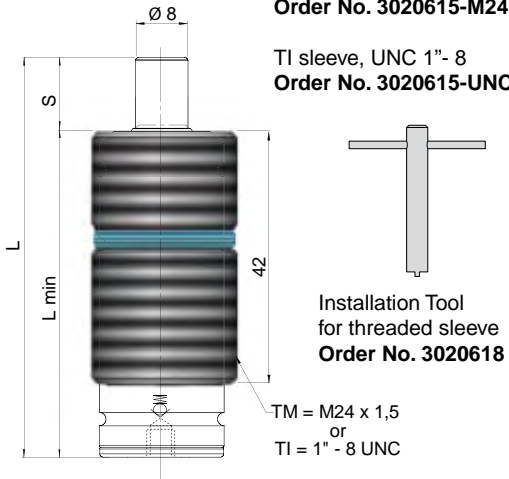

The R series get their name from the fact their tube is roll formed and therefore permanently closed, making them non-repairable.

R series springs are available with Ø 12, Ø 15, and Ø 19 mm tube diameters and with stroke lengths up to 125 mm.

There are 4 color-coded models, whose forces are preset. An adjustable model (black) is also available, that can be ordered to a specific charge pressure or adjusted by customers with the appropriate charging equipment and training.

How to order R19 - 7 Yellow

Model: R19
 Stroke Length (mm) (7, 10, 15, 25, 38.1, 50, 63.5, 80, 100, 125)
 Force: Green, Blue, Red, Yellow, Black, state desired force in N

Model	Force in N at +20°C		Colour	Charging pressure (bar)
	Initial			
R19 30	300		Green	60
R19 50	500		Blue	100
R19 70	700		Red	140
R19 90	900		Yellow	180
R19 XX*	125-900		Black	25-180

*Force to be set by the end user. Delivered with a pre-charge of 5-10 bar.

S Stroke	End force in N at + 20°C*				L ±0.25	L min	Gas vol. (l)	Weight (kg)	ISO
	R19 30	R19 50	R19 70	R19 90					
7	530	880	1200	1600	56	49	0.003	0.07	
10	470	780	1100	1400	62	52	0.003	0.08	
15	440	730	1000	1300	72	57	0.004	0.08	✓
25	420	700	980	1300	92	67	0.006	0.08	✓
38.1	410	690	970	1200	118.2	80.1	0.009	0.10	✓
50	410	680	960	1200	142	92	0.011	0.12	✓
63.5	410	680	950	1200	172	108.5	0.014	0.13	✓
80	410	680	950	1200	205	125	0.018	0.14	✓
100	410	670	940	1200	245	145	0.022	0.17	
125	410	670	940	1200	295	170	0.027	0.20	

*at full stroke

Basic Information

For general information see "About gas springs", 2.1
 Pressure medium Nitrogen
 Max. charging pressure 180 bar
 Min. charging pressure 25 bar
 Operating temperature 0 to +80°C
 Force increase by temperature ± 0.3%/°C
 Recommended max strokes/min ~ 100-150 (at 20°C)
 Max piston rod velocity 1.6 m/s

Rod surface..... Nitrided
 Tube surface Black oxide
 Repair kit..... Non-repairable

Mounting Possibilities

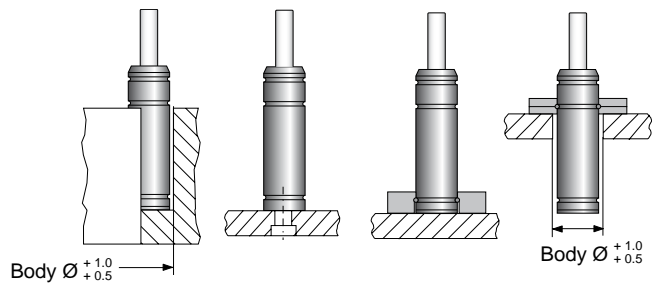

Drop - In
Base Mount B only to be used for strokes 7-25 mm
Foot Mount BF-19 only to be used for strokes 7-25 mm
Top Mount FCR-19

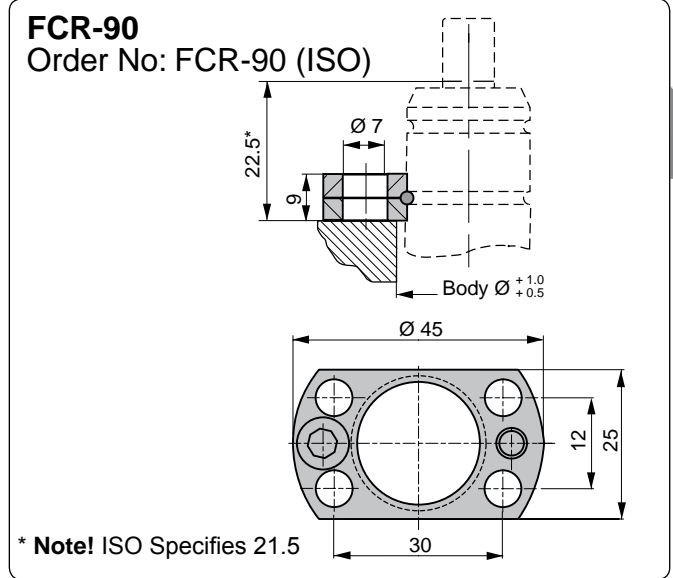
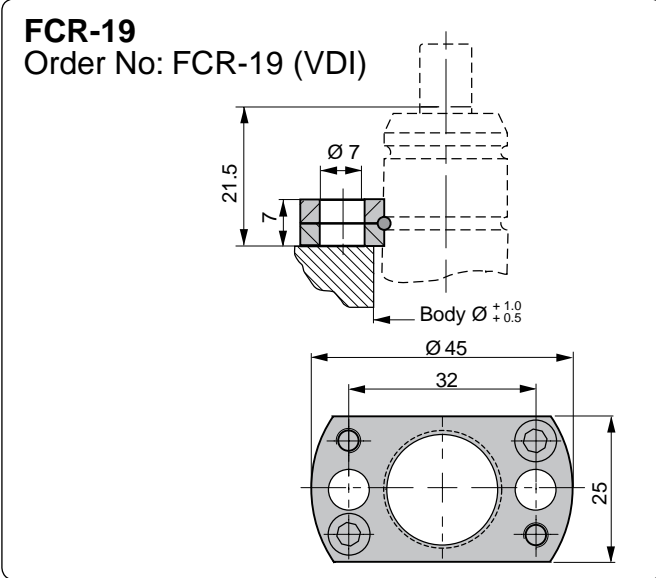

2

* Note! ISO Specifies 21.5

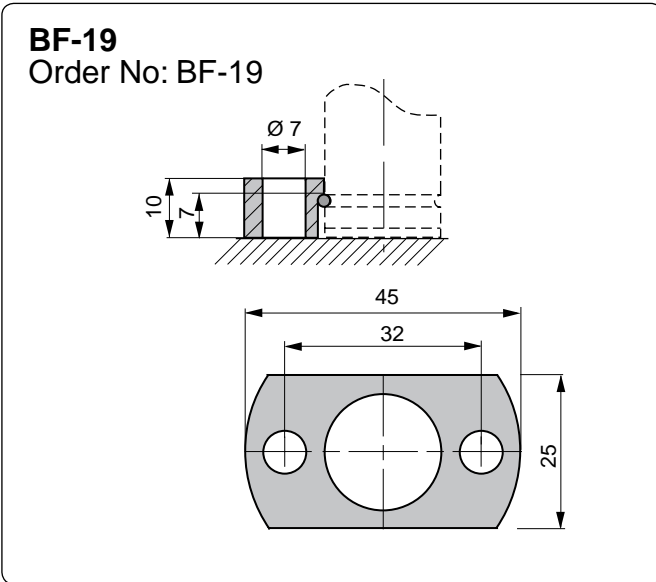



2

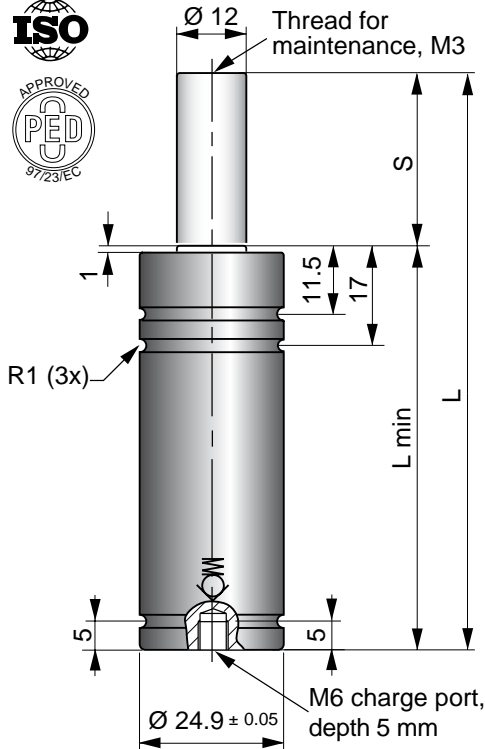

The M2 is available in four preset models, with initial forces from 500 to 2000 N. The body of the spring and the mount are designed to meet the ISO-dimension found in ISO 11901 as well as in VDI 3003. Each spring is color-coded for easy identification of force rating.

We also offer a model with adjustable force (black) that can be customised to meet individual force requirements. The adjustable model may be set to desired pressure when ordered from us or by customers with charging equipment.

The M2 spring can in many cases directly replace mechanical die springs of 25 mm (1 inch) diameter.

All M2 springs can be repaired and recharged. The spring can be attached to the tool, using a mount (FCR or SM). The M6 thread in the base of the spring is used for charging and is also a mounting option.

Model	Force in Nat +20°C	Colour	Charging pressure (bar)
	Initial		
M2 50	500	Green	45
M2 100	1000	Blue	90
M2 150	1500	Red	135
M2 200	2000	Yellow	180
M2 XX*	280-2000	Black	25-180

*Force to be set by the end user. Delivered with a pre-charge of 5-10 bar.

S Stroke	End force in N at + 20°C*								L ±0.25	L min	Gas vol. (l)	Weight (kg)	ISO
	Volvo Part No.	M2 050	Volvo Part No.	M2 100	Volvo Part No.	M2 150	Volvo Part No.	M2 200					
10	3044235	770	3044243	1530	3044251	2300	3045021	3060	62	52	0.005	0.14	
12.7	3044236	770	3044244	1530	3044252	2300	3045022	3070	67.4	54.7	0.006	0.15	
15		770		1540		2310		3070	72	57	0.007	0.16	✓
16	3044237	770	3044245	1540	3044253	2310	3045023	3070	74	58	0.007	0.16	
25	3044238	770	3044246	1540	3044254	2310	3045024	3080	92	67	0.010	0.18	✓
38.1	3044239	770	3044247	1540	3044255	2320	3045025	3090	118.2	80.1	0.015	0.20	✓
50	3044240	770	3044248	1540	3044256	2320	3045026	3090	142	92	0.019	0.22	✓
63.5	3044241	760	3044249	1520	3044257	2270	3045027	3020	172	108.5	0.024	0.26	✓
80	3044242	760	3044250	1520	3044258	2280	3045028	3040	205	125	0.029	0.30	✓
100	3049564	760	3049566	1520	3049568	2290	3045029	3050	245	145	0.036	0.33	✓
125	3049565	760	3049567	1530	3049569	2290	3045030	3060	295	170	0.044	0.39	✓

*at full stroke

How to order

M2 -10 Green

Model
Stroke Length (mm)
(10, 12.7, 15, 16, 25, 38.1, 50, 63.5, 80, 100, 125)

Force:
Green
Blue
Red
Yellow
Black, state
desired force in N

Basic Information

- For general information see "About gas springs", 2.1
- Pressure medium Nitrogen
- Max. charging pressure 180 bar
- Min. charging pressure 25 bar
- Operating temperature 0 to +80°C
- Force increase by temperature ±0.3%/°C
- Recommended max strokes/min ... ~ 80-100 (at 20°C)
- Max piston rod velocity 1.6 m/s
- Rod surface Nitrided
- Tube surface Black oxide
- Repair kit 3016385

Mounting Possibilities

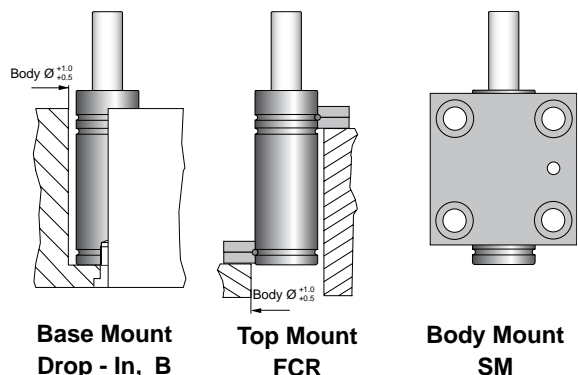

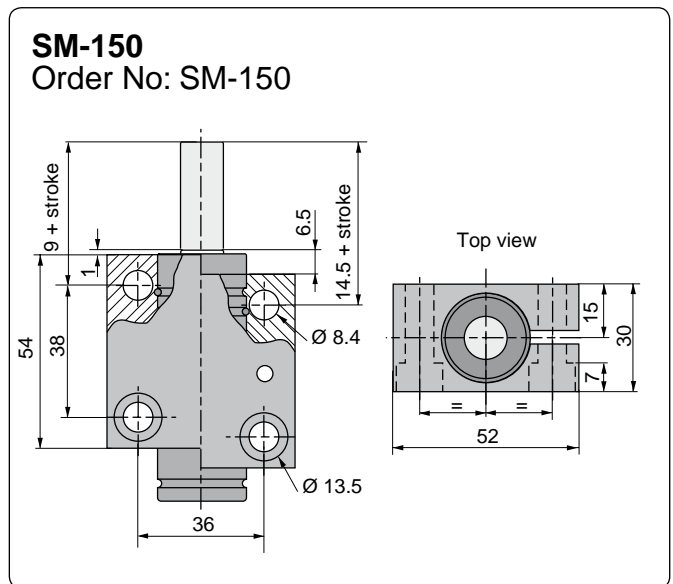
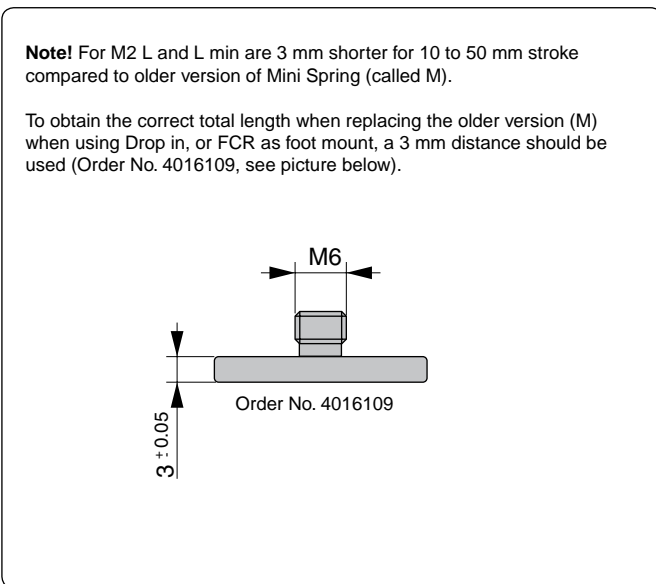
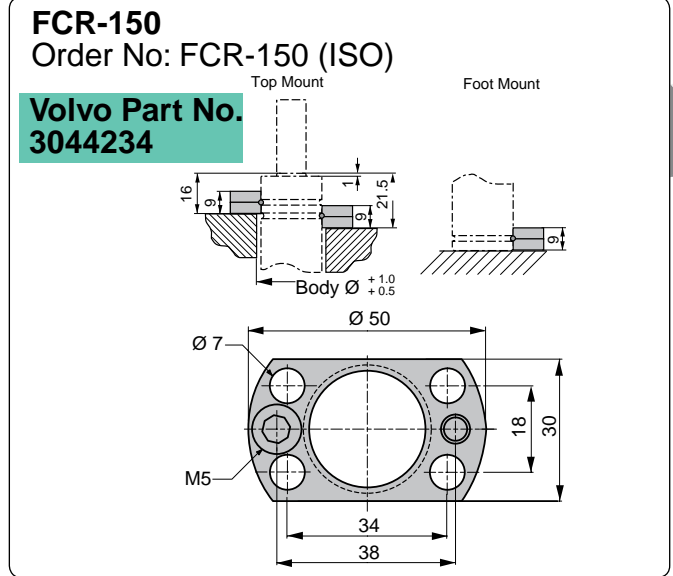
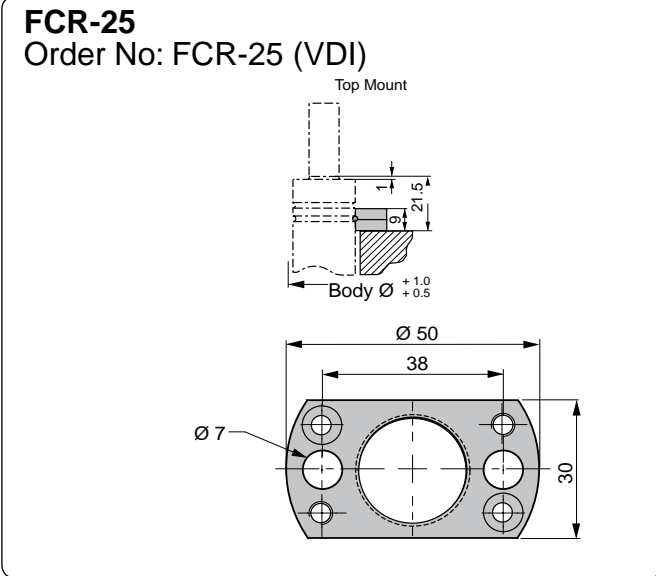

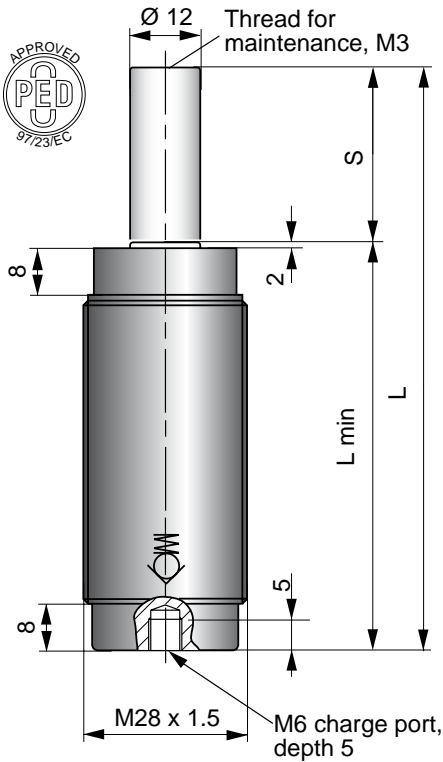

How to order

MM2 -10 Black

Model

Stroke Length (mm)
(10, 12.7, 15, 16, 25, 38.1, 50, 63.5, 80, 100, 125)

Force:
Green
Blue
Red
Yellow
Black, state desired force in N

The MM2 is a version of the M2 spring with a threaded body, (M28 x 1.5). All internal parts and technical data are the same as for M2 springs (with the exception of strokes 63.5 to 125 whose total lengths are 3 mm shorter). Each spring is color-coded for easy identification of force rating.

We also offer a model with adjustable force (black) that can be customised to meet individual force requirements. The adjustable model may be set to desired pressure when ordered from us or by customers with charging equipment.

All MM2 springs can be repaired and recharged.

For locking the spring in the tool a lock nut is available.

Model	Force in N at +20°C		Colour	Charging pressure (bar)
	Initial			
MM2 50	500		Green	45
MM2 100	1000		Blue	90
MM2 150	1500		Red	135
MM2 200	2000		Yellow	180
MM2 XX*	280-2000		Black	25-180

*Force to be set by the end user. Delivered with a pre-charge of 5-10 bar.

S Stroke	End force in N at + 20°C*				L ±0.25	L min	Gas vol. (l)	Weight (kg)
	MM2 50	MM2 100	MM2 150	MM2 200				
10	770	1530	2300	3060	62	52	0.005	0.14
12.7	770	1530	2300	3070	67.4	54.7	0.006	0.15
15	770	1540	2310	3070	72	57	0.007	0.16
16	770	1540	2310	3070	74	58	0.007	0.16
25	770	1540	2310	3080	92	67	0.010	0.18
38.1	770	1540	2320	3090	118.2	80.1	0.015	0.20
50	770	1540	2320	3090	142	92	0.019	0.22
63.5	760	1520	2270	3020	169	105.5	0.024	0.26
80	760	1520	2280	3040	202	122	0.029	0.30
100	760	1520	2290	3050	242	142	0.036	0.33
125	760	1530	2290	3060	292	167	0.044	0.39

*at full stroke

Basic Information

- For general information see "About gas springs", 2.1
- Pressure medium Nitrogen
- Max. charging pressure 180 bar
- Min. charging pressure 25 bar
- Operating temperature 0 to +80°C
- Force increase by temperature ±0.3%/°C
- Recommended max strokes/min ... ~ 80-100 (at 20°C)
- Max piston rod velocity 1.6 m/s
- Rod surface..... Nitrided
- Tube surface Black oxide
- Repair kit 3016385

Mounting Possibilities

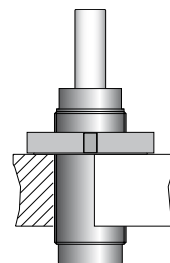

Thread Mount FRM

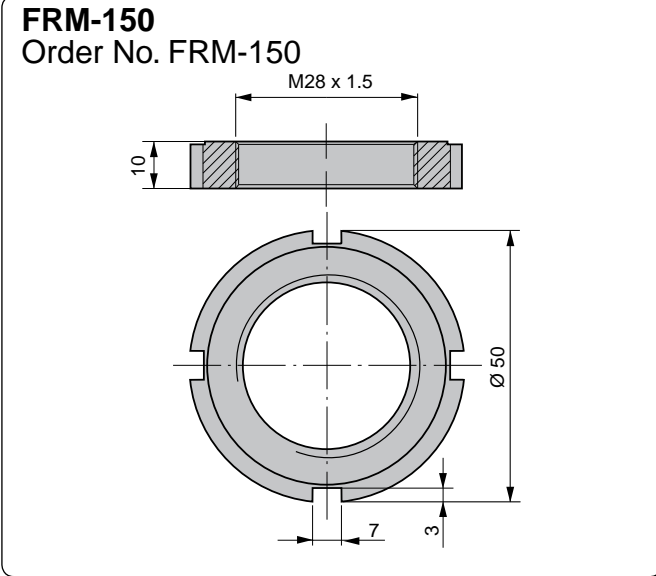



2

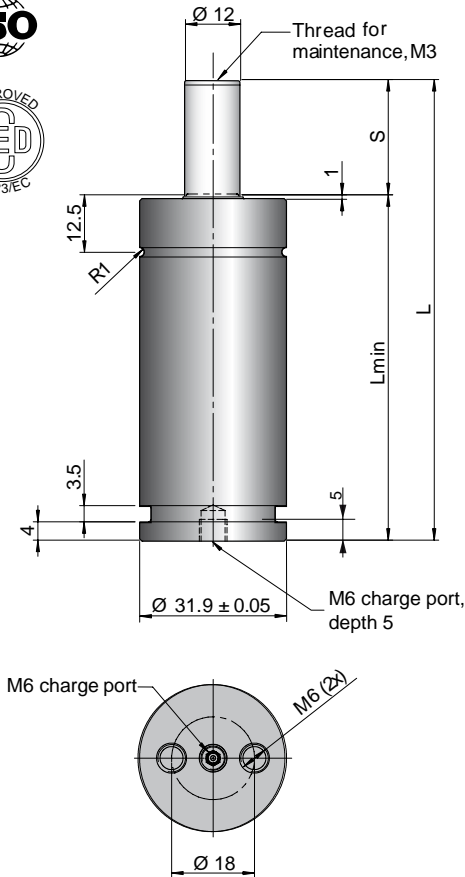

The MC3 spring is based on the M2 spring, using the same piston rod and internal components. The body of the spring and the mount are designed to meet the ISO-dimension found in ISO 11901 as well as in VDI 3003.

Each spring is color-coded for easy identification of force rating. We also offer a model with adjustable force (black) that can be customised to meet individual force requirements. The adjustable model may be set to desired pressure at the factory or by customers with charging equipment.

The spring can be attached to the tool, using mounts FC-MC or FFC-MC. The M6 threads in the base of the spring are used for charging respective as mounting option.

Model	Force in N at +20°C		Colour	Charging pressure (bar)
	Initial			
MC3 50	500		Green	45
MC3 100	1000		Blue	90
MC3 150	1500		Red	135
MC3 200	2000		Yellow	180
MC3 XX*	280-2000		Black	25-180

*Force to be set by the end user. Delivered with a pre-charge of 5-10 bar.

How to order

MC3 -10 Red

Model

Stroke Length (mm)
(10, 12.7, 15, 16, 25, 38.1, 50, 63.5, 80, 100, 125)

Force:

- Green
- Blue
- Red
- Yellow
- Black, state desired force in N

S Stroke	End force in N at +20°C*				L ±0.25	L min	Gas vol. (l)	Weight (kg)	ISO
	MC3 50	MC3 100	MC3 150	MC3 200					
10	770	1530	2300	3060	70	60	0.005	0.30	✓
12.7	770	1530	2300	3070	75.4	62.7	0.006	0.31	
16	770	1540	2310	3070	82	66	0.007	0.33	✓
25	770	1540	2310	3080	100	75	0.010	0.38	✓
38.1	770	1540	2320	3090	126.2	88.1	0.015	0.43	
50	770	1540	2320	3090	150	100	0.019	0.48	✓
63.5	760	1520	2270	3020	177	113.5	0.024	0.54	
80	760	1520	2280	3040	210	130	0.029	0.62	✓
100	760	1520	2290	3050	250	150	0.036	0.71	
125	760	1530	2290	3060	300	175	0.044	0.83	

*at full stroke

Basic Information

- For general information see "About gas springs", 2.1
- Pressure medium Nitrogen
- Max. charging pressure 180 bar
- Min. charging pressure 25 bar
- Operating temperature 0 to +80°C
- Force increase by temperature ±0.3%/°C
- Recommended max strokes/min ... ~ 80-100 (at 20°C)
- Max piston rod velocity 1.6 m/s

- Rod surface..... Nitrided
- Tube surface Black oxide
- Repair kit 3016385

Mounting Possibilities

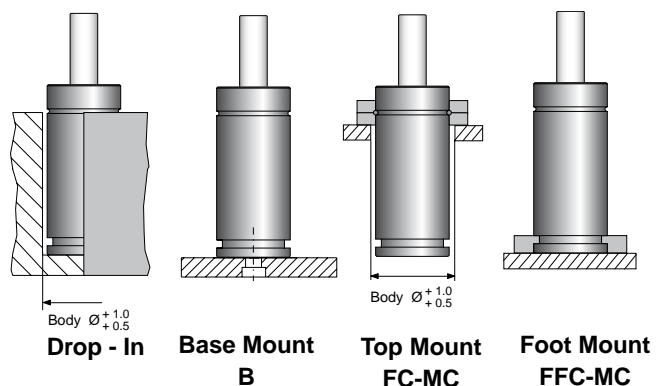

FC-MC-150
Order No. FC-MC-150

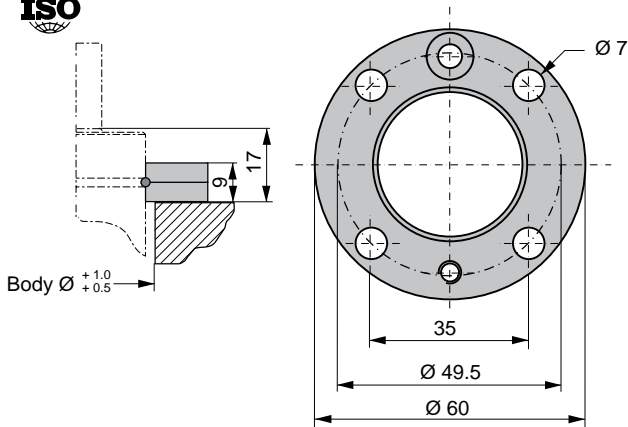

FFC-MC-150
Order No. FFC-MC-150

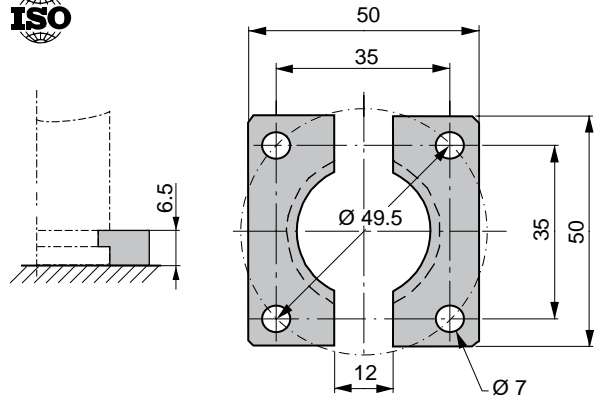

S-MC
Order No. S-MC

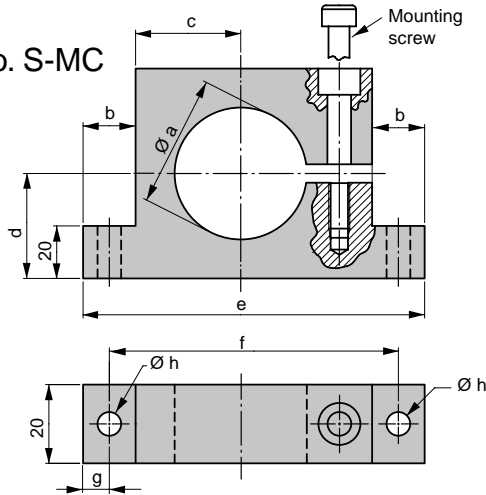

Order No.	Ø a	b	c	d	e	f	g	Ø h
S-MC	32.1	18	22	22.5	90	72	9	8.5

FCS-32
Order No. FCS-32

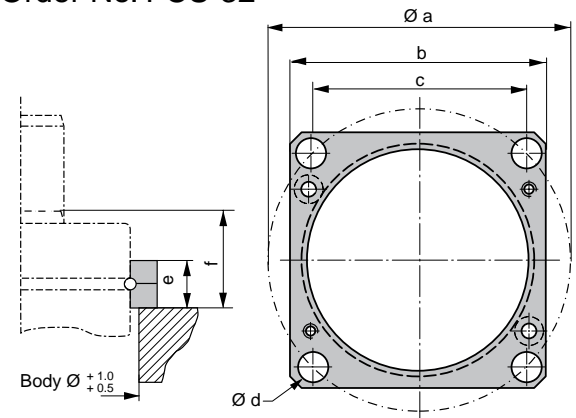

Order No.	Ø a	b	c	Ø d	e	f
FCS-32	49.5	45	35	7	9	16



2

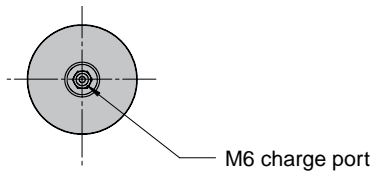
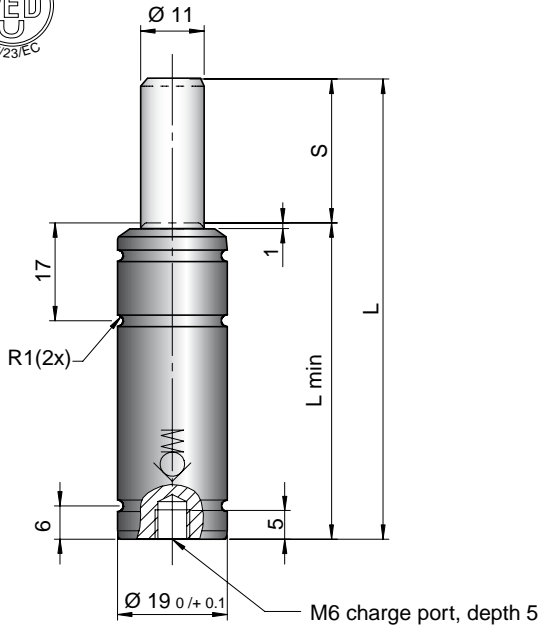

The Power Line series are our shortest and most powerful Piston Rod Sealed gas springs, giving you a great deal of force in a very small amount of space.

The Power Line springs are available with forces from 1700 N up to 200000 N and stroke lengths between 7 and 125 mm.

The X 170 has a bottom port for gas charging that can also be used to connect to a gas link system.

The X 170 has an upper ISO-Standard C-groove and a lower C-groove which together with a threaded bottom hole offers various mounting possibilities using our standard mounts.

Order No.	S Stroke	Force in N at 180 bar/+20°C		L ±0.25	L min	Gas vol. (l)	Weight (kg)
		Initial	End force*				
X 170-007	7	1700	2800	44	37	0.002	0.06
X 170-010	10			50	40	0.002	0.06
X 170-015	15			60	45	0.004	0.07
X 170-019	19			68	49	0.005	0.07
X 170-025	25			80	55	0.006	0.08
X 170-038	38			106	68	0.009	0.09
X 170-050	50			130	80	0.012	0.10
X 170-063	63			156	93	0.015	0.12
X 170-075	75			185	110	0.018	0.13
X 170-080	80			195	115	0.019	0.14
X 170-100	100			235	135	0.024	0.16
X 170-125	125			285	160	0.030	0.19

* = at full stroke

Basic Information

- For general information see "About gas springs", 2.1
- Pressure medium Nitrogen
- Max. charging pressure 180 bar (at 20° C)
- Min. charging pressure 25 bar (at 20° C)
- Operating temperature 0 to +80°C
- Force increase by temperature ±0.3%/°C
- Recommended max strokes/min ... ~ 40-100 (at 20°C)
- Max piston rod velocity 1.6 m/s
- Rod surface..... Nitrided
- Tube surface Black oxide
- Repair kit Non-repairable

Mounting Possibilities

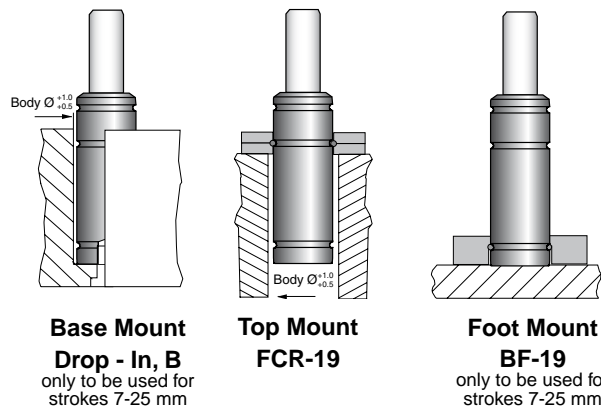

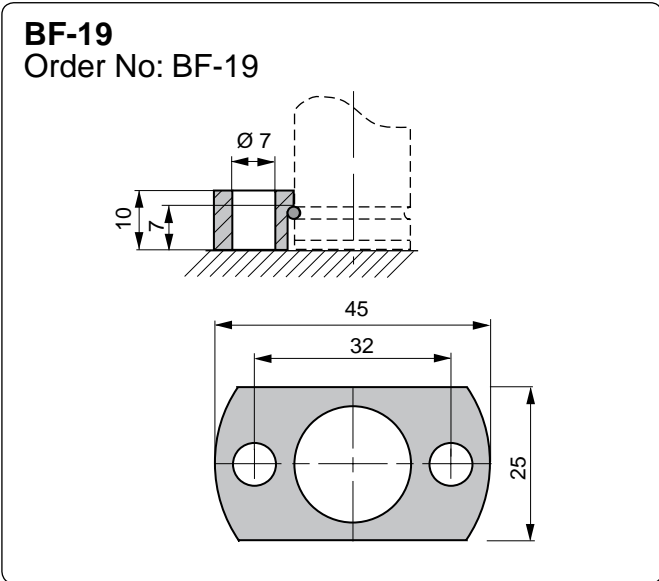
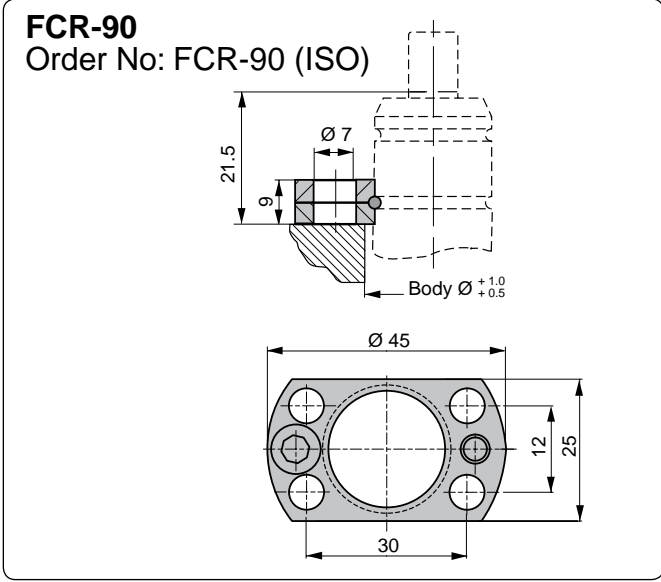
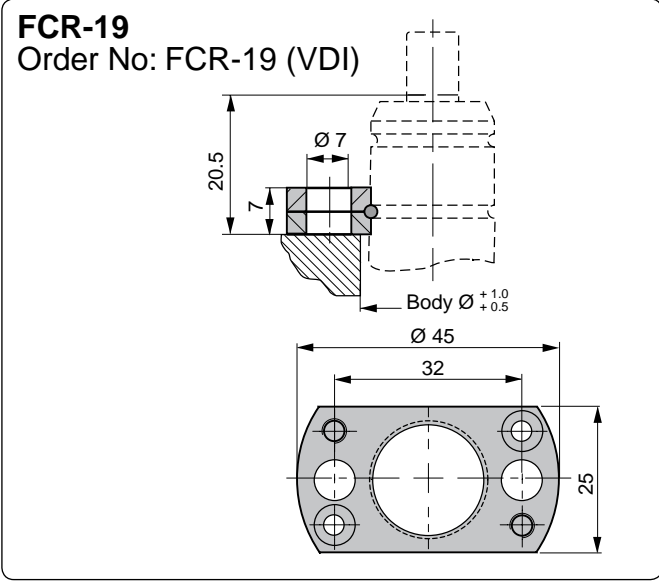

Overview - $2500 \leq F_{INIT} < 5000$

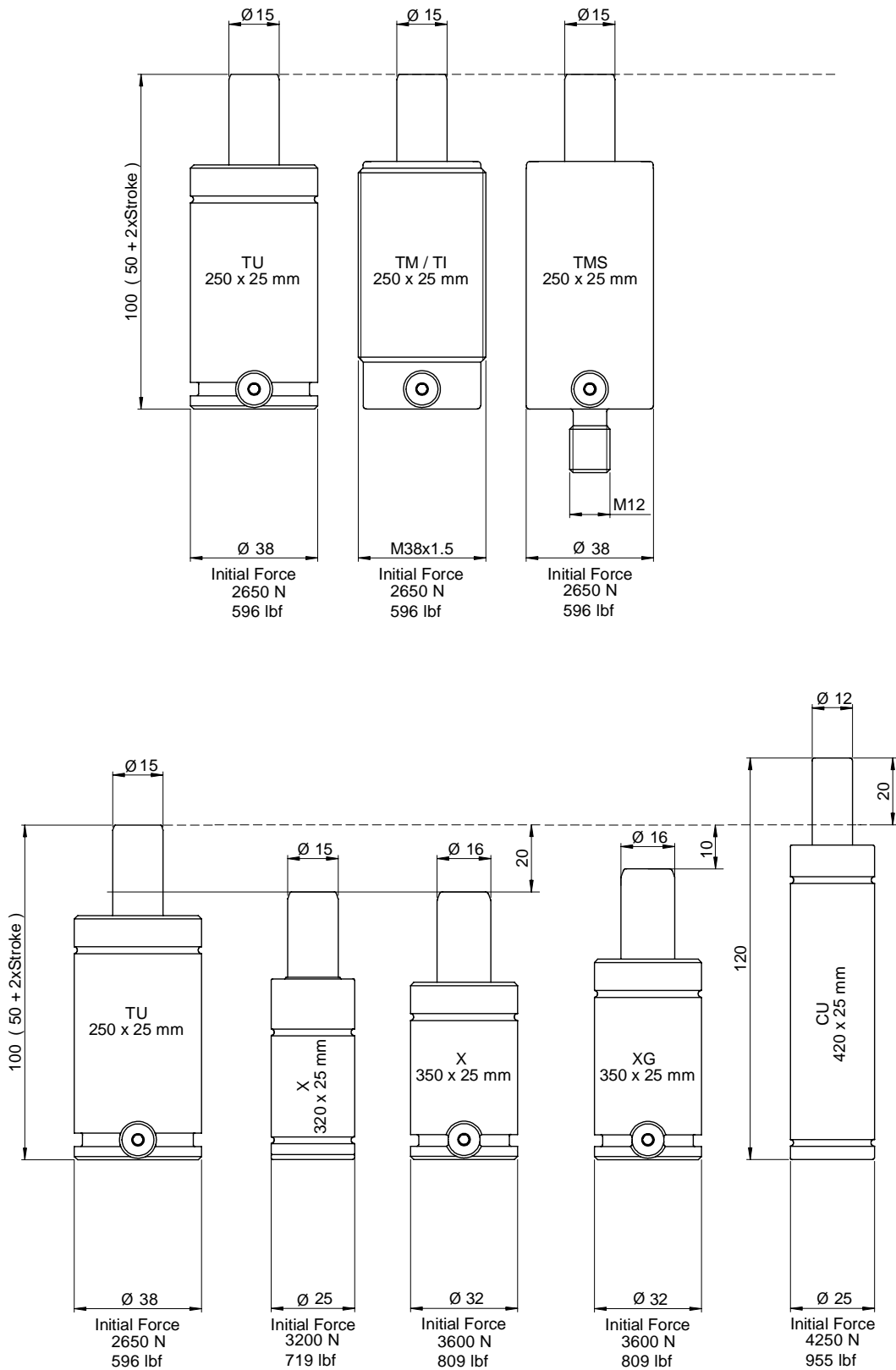

$2500 \leq F_{INIT} < 5000$

CU 420

Page 2.3/2

X 320



Page 2.3/4

X 350

Page 2.3/6

XG 350



Page 2.3/8

TU 250



Page 2.3/10

TM/TI 250



Page 2.3/12

TMS 250



Page 2.3/14



This is the smallest member of the CU family. As with the rest of the CU springs it has a very high force compared to its outer diameter.

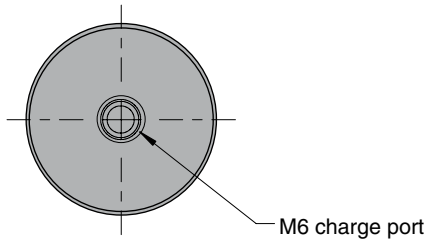
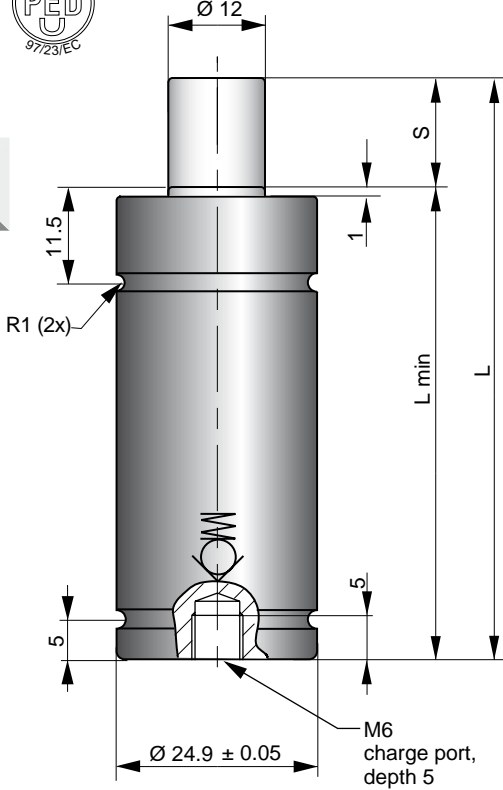

Volvo Part No.	Order No.	S Stroke	Force in N at 150 bar/+20°C		L ±0.25	L min	Gas vol. (l)	Weight (kg)
			Initial	End force*				
3054657	CU 420-006	6	4250	7000	56	50	0.003	0.13
	CU 420-010	10		6900	70	60	0.005	0.15
3054658	CU 420-016	16		6900	91	75	0.008	0.18
3054659	CU 420-025	25		6900	120	95	0.011	0.22
3054660	CU 420-032	32		7600	140	108	0.021	0.24
3054661	CU 420-040	40		7600	165	125	0.026	0.27
3054662	CU 420-050	50		7600	195	145	0.032	0.31

* = at full stroke

Basic Information

For general information see "About gas springs", 2.1
 Pressure medium..... Nitrogen
 Max. charging pressure..... 150 bar (at 20°C)
 Min. charging pressure..... 25 bar (at 20°C)
 Operating temperature 0 to +80°C
 Force increase by temperature ±0.3%/°C
 Recommended max strokes/min 50~100 (at 20° C)
 Max piston rod velocity 0.5 m/s

Rod surface..... Nitrided
 Tube surface Nitrided
 Repair kit Non-repairable

Mounting Possibilities

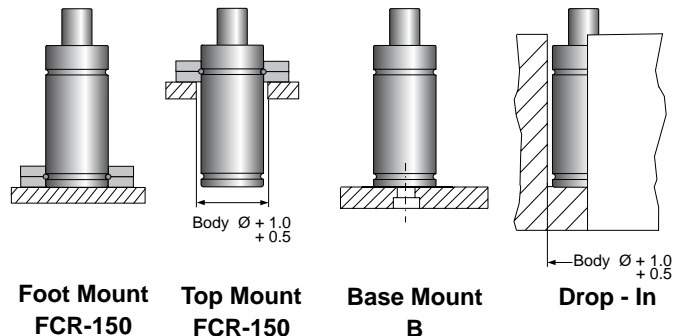

FCR

Order No: FCR-150

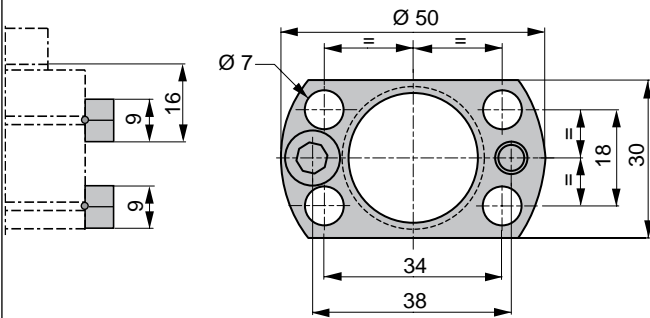
Volvo Part No.
3044234

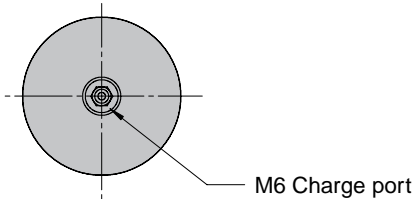
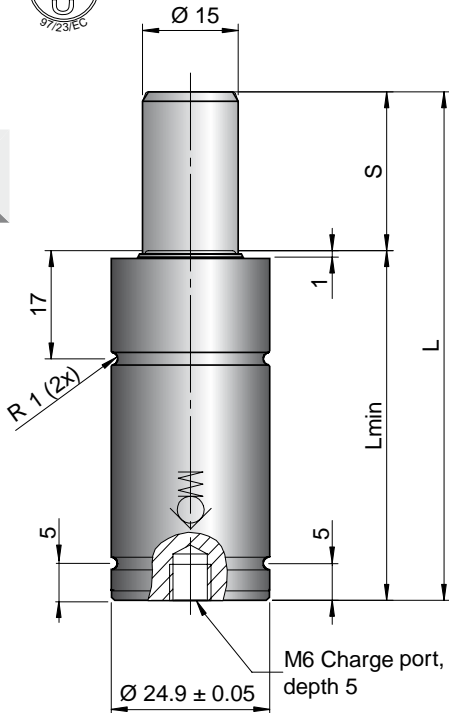

The Power Line series are our shortest and most powerful Piston Rod Sealed gas springs, giving you a great deal of force in a very small amount of space.

The Power Line springs are available with forces from 1700 N up to 200000 N and stroke lengths between 7 and 125 mm.

The X 320 has a bottom port for gas charging that can also be used to connect to a gas link system.

The X 320 has an upper ISO-Standard C-groove that together with a threaded bottom hole offers various mounting possibilities using our standard mounts.

Order No.	S Stroke	Force in N at 180 bar/+20°C		L ±0.25	L min	Gas vol. (l)	Weight (kg)
		Initial	End force*				
X 320-007	7	3200	4800	44	37	0.004	0.10
X 320-010	10		4900	50	40	0.005	0.11
X 320-015	15		5100	60	45	0.007	0.12
X 320-019	19		5100	68	49	0.009	0.13
X 320-025	25		5200	80	55	0.011	0.14
X 320-038	38**		5300	106	68	0.017	0.16
X 320-050	50**		5300	130	80	0.022	0.18
X 320-063	63**		5300	156	93	0.028	0.21
X 320-075	75**		5300	185	110	0.034	0.24
X 320-080	80**		5300	195	115	0.036	0.25
X 320-100	100**		5300	235	135	0.044	0.29
X 320-125	125**		5300	285	160	0.055	0.33

*= at full stroke.

Basic Information

For general information see "About gas springs", 2.1
 Pressure medium Nitrogen
 Max. charging pressure 180 bar (at 20° C)
 Min. charging pressure 25 bar (at 20° C)
 Operating temperature 0 to +80°C
 Force increase by temperature ±0.3%/°C
 Recommended max strokes/min ... ~ 40-100 (at 20°C)
 Max piston rod velocity 1.6 m/s

Rod surface..... Nitrided
 Tube surface Black oxide
 Repair kit Non-repairable

Mounting Possibilities

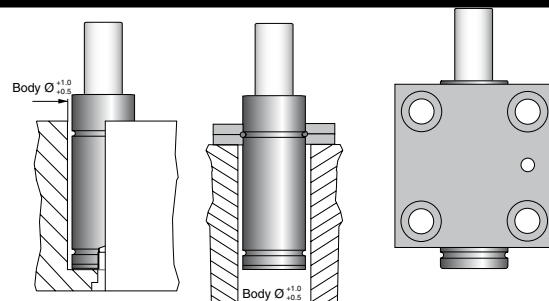

Base Mount Drop - In, B
only to be used for strokes 7-25

Top Mount FCR-150

Body Mount SM -150

FCR

Order No: FCR-150

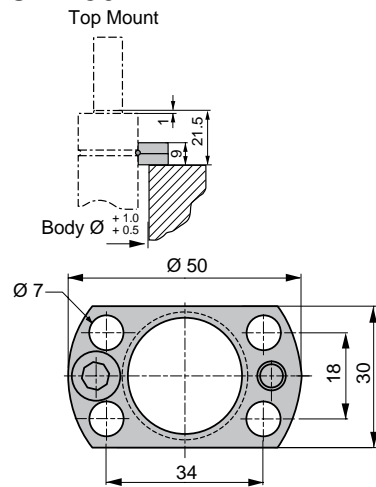
**SM**

Order No: SM-150

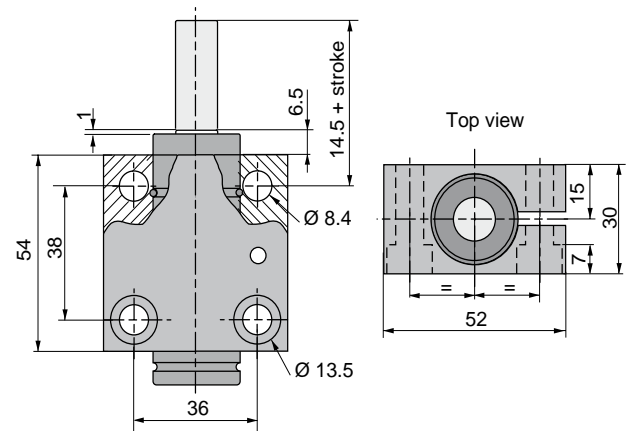

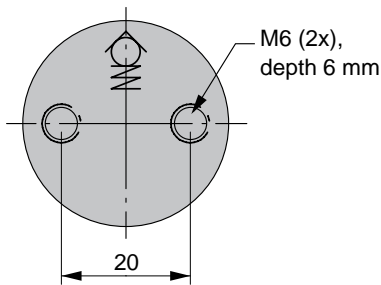
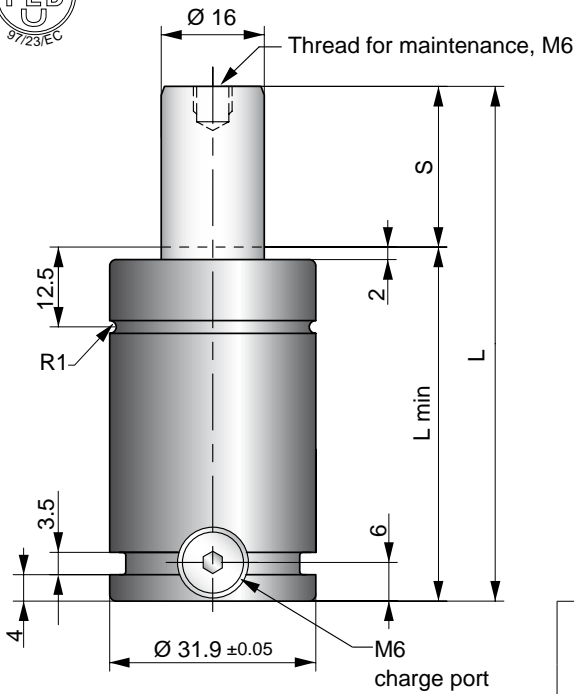

The Power Line series are our shortest and most powerful Piston Rod Sealed gas springs, giving you a great deal of force in a very small amount of space.

These gas springs are available with forces from 1700 N up to 200000 N and stroke lengths between 7 and 125 mm.

There is a side port for gas charging that can also be used to connect to a gas link system.

An upper C-groove, lower U-groove together with two M6 threaded holes allow various mounting possibilities using our standard mounts.

Volvo Part No.	Order No.	S Stroke	Force in N at 180 bar/+20°C		L ±0.25	L min	Gas vol. (l)	Weight (kg)
			Initial	End force*				
3050731	X 350-010	10	3600	5900	50	40	0.01	0.17
3050732	X 350-013	13		5200	56	43	0.01	0.18
3050733	X 350-016	16		5300	62	46	0.01	0.19
3050734	X 350-019	19		5600	68	49	0.01	0.20
3050735	X 350-025	25		5500	80	55	0.02	0.22
3050736	X 350-032	32		5500	94	62	0.02	0.24
3050737	X 350-038	38		5500	106	68	0.03	0.26
3050738	X 350-050	50		5600	130	80	0.03	0.29
3050739	X 350-063	63		5500	156	93	0.04	0.33
3050740	X 350-075	75		5500	180	105	0.05	0.37
3050741	X 350-080	80		5500	190	110	0.05	0.39
3050742	X 350-100	100		5500	230	130	0.06	0.45
	X 350-125	125		5500	280	155	0.08	0.53

* = at full stroke

Basic Information

- For general information see "About gas springs", 2.1
- Pressure medium Nitrogen
- Max. charging pressure 180 bar (at 20°C)
- Min. charging pressure 25 bar (at 20°C)
- Operating temperature 0 to +80°C
- Force increase by temperature ±0.3%/°C
- Recommended max strokes/min ... ~ 50 to 100 (at 20°C)
- Max piston rod velocity 1.6 m/s

- Rod surface Nitrided
- Tube surface Black oxide
- Repair kit 3018845

Repair kit volvo Part No.....3050726

Mounting Possibilities

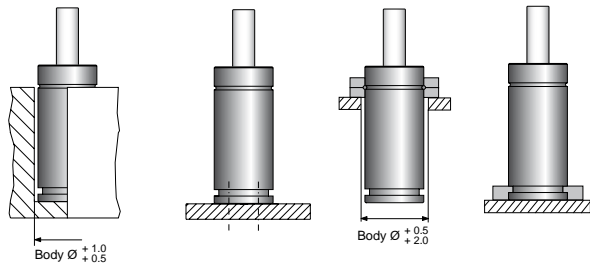

Drop - In

Base Mount B

Top Mount FC-MC

Foot Mount FFC-MC

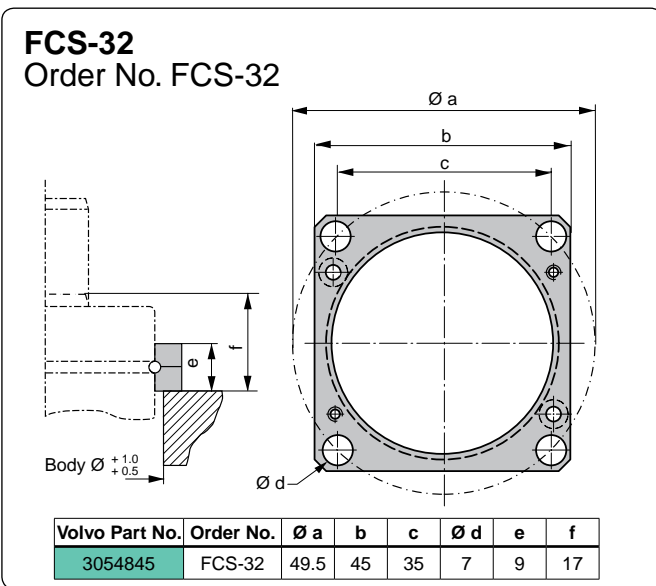
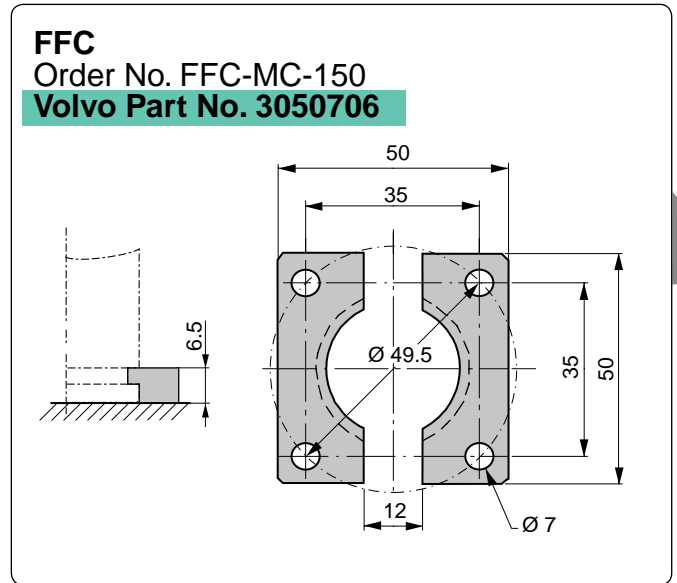
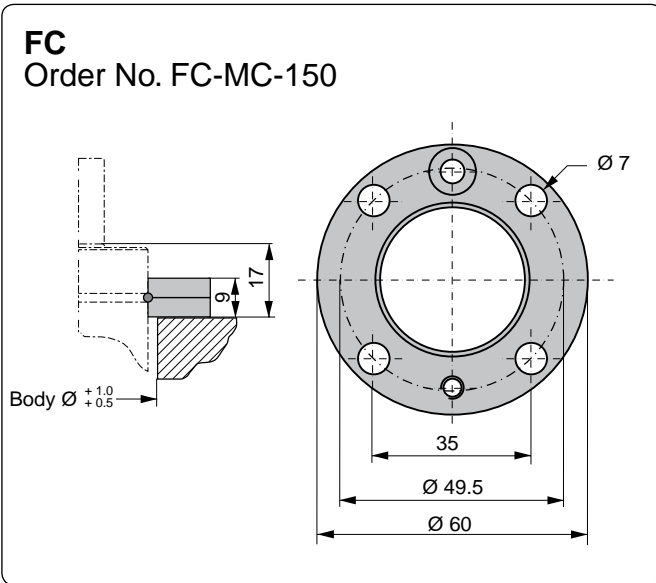

The Power Line series are our shortest and most powerful Piston Rod Sealed gas springs, giving you a great deal of force in a very small amount of space.

These gas springs are available with forces from 3500 N up to 66000 N and stroke lengths between 10 and 125 mm.

There is a side and a bottom port for gas charging that can also be used to connect to a hose system.

An upper C-groove, lower U-groove together with two M6 threaded holes allow various mounting possibilities using our standard mounts.

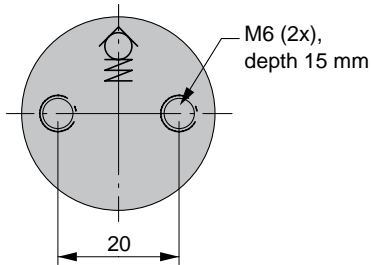
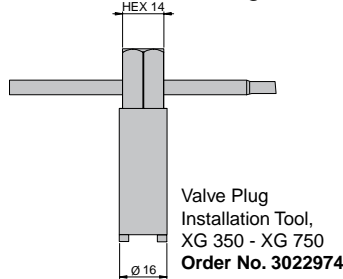
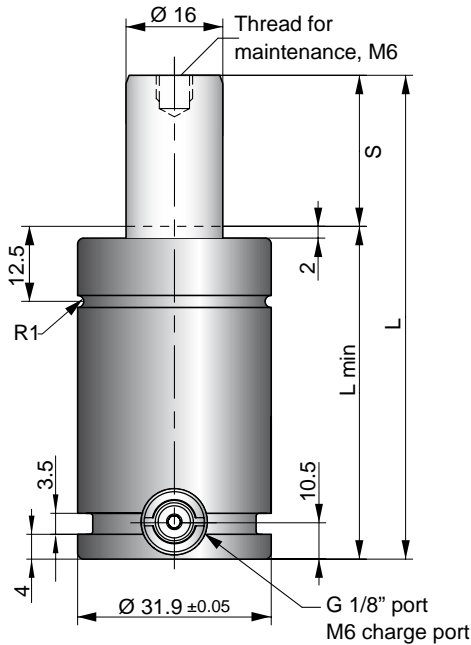

Order No.	S Stroke	Force in N at 180 bar/+20°C		L ±0.25	L min	Gas vol. (l)	Weight (kg)
		Initial	End force*				
XG 350-010	10	3600	5900	60	50	0.01	0.23
XG 350-013	13		5200	66	53	0.01	0.23
XG 350-016	16		5300	72	56	0.01	0.24
XG 350-019	19		5600	78	59	0.01	0.25
XG 350-025	25		5500	90	65	0.02	0.27
XG 350-032	32		5500	104	72	0.02	0.29
XG 350-038	38		5500	116	78	0.03	0.31
XG 350-050	50		5600	140	90	0.03	0.35
XG 350-063	63		5500	166	103	0.04	0.39
XG 350-075	75		5500	190	115	0.05	0.43
XG 350-080	80		5500	200	120	0.05	0.44
XG 350-100	100		5500	240	140	0.06	0.50
XG 350-125	125		5500	290	165	0.08	0.58

* = at full stroke

Basic Information

- For general information see "About gas springs", 2.1
- Pressure medium Nitrogen
- Max. charging pressure 180 bar (at 20°C)
- Min. charging pressure 25 bar (at 20°C)
- Operating temperature 0 to +80°C
- Force increase by temperature ±0.3%/°C
- Recommended max strokes/min ... ~ 50 to 100 (at 20°C)
- Max piston rod velocity 1.6 m/s

- Rod surface Nitrided
- Tube surface Black oxide
- Repair kit 3018845

Mounting Possibilities

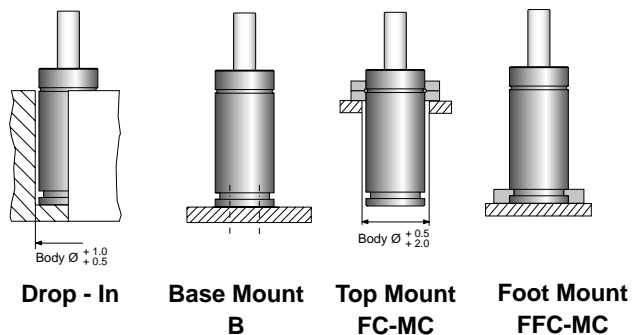

FC

Order No. FC-MC-150

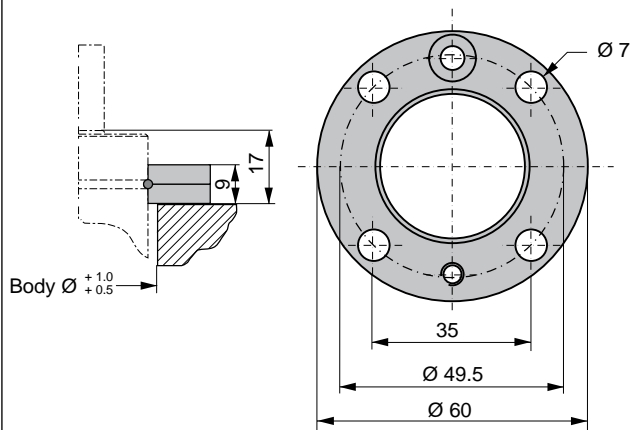
**FFC**

Order No. FFC-MC-150

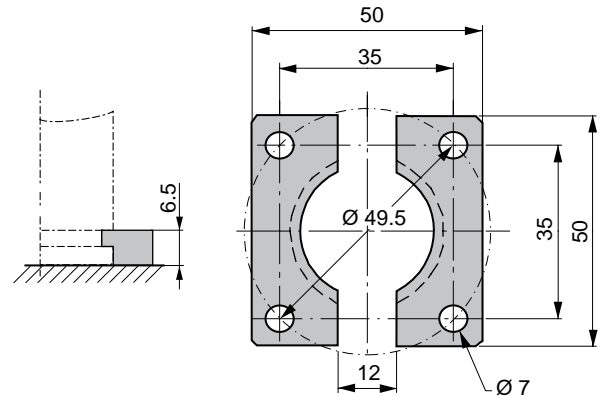



3

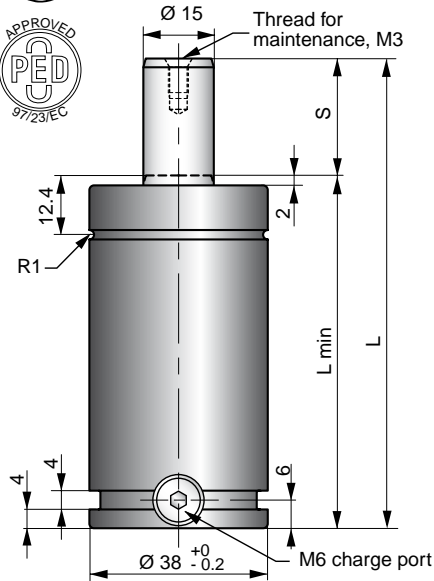

Standard line of gas springs is the TU- line. Sizes 250 to 10 000 correspond to the ISO 11901 standard for gas springs as well as VDI 3003.

The total length L is 50 mm + (2 x stroke).

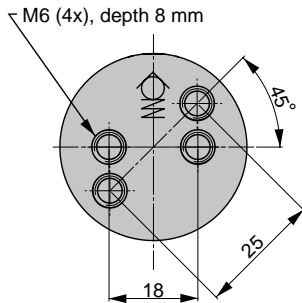

Volvo Part No.	Order No.	S Stroke	Force in Nat 150 bar/+20°C		L ±0.25	L min	Gas vol. (l)	Weight (kg)	ISO 11901
			Initial	End force*					
3044172	TU 250-010	10	2650	3500	70	60	0.011	0.40	√
	TU 250-013	12.7		3500	75.4	62.7	0.013	0.42	
3044173	TU 250-016	16		3500	82	66	0.016	0.43	√
3044174	TU 250-025	25		3500	100	75	0.023	0.48	√
	TU 250-038	38.1		3500	126.2	88.1	0.032	0.54	
3044175	TU 250-050	50		3500	150	100	0.041	0.60	√
	TU 250-064	63.5		3500	177	113.5	0.051	0.67	
3044176	TU 250-080	80		3500	210	130	0.062	0.75	√
	TU 250-100	100		3500	250	150	0.077	0.85	
	TU 250-125	125		3500	300	175	0.096	0.97	

* = at full stroke

Basic Information

For general information see "About gas springs", 2.1
 Pressure medium Nitrogen
 Max. charging pressure 150 bar
 Min. charging pressure 50 bar
 Operating temperature 0 to +80°C
 Force increase by temperature ±0.3%/°C
 Recommended max strokes/min ... ~ 80-100 (at 20°C)
 Max piston rod velocity 1.6 m/s

Rod surface..... Nitrided
 Tube surface Black oxide
 Repair kit 3016873
 Repair kit volvo Part No..... 3050719

Mounting Possibilities

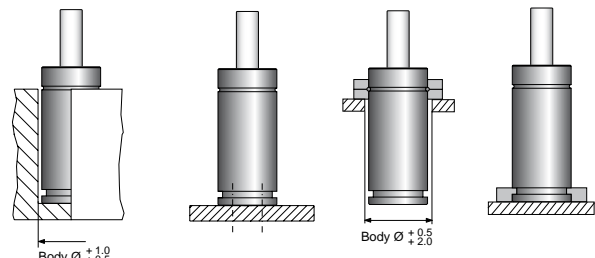

Drop - In **Base Mount B** **Top Mount FC, FCS** **Foot Mount K, FFC**

Note! For dimensions on mounting possibilities K-250 refer to Chapter 3.

FC
ISO

Order No.	Ø a	Ø b	c	Ø d	e	f
FC-250	68	56.5	40	7	9	17

FCS
ISO

Volvo Part No.	Order No.	Ø a	b	c	Ø d	e	f
3044689	FCS-250	56.5	52	40	7	9	17

FFC
ISO

Volvo Part No.	Order No.	a	b	Ø c	Ø d	e	f
3050707	FFC-250	55	40	56.6	7	12	6.5

S
ISO

Note! Support S is designed to be used in combination with flanges mounted in the U or C groove or mount option B.

The mounting screw (M6) should be tightened with torque 25 Nm.

Order No.	Ø a	b	c	d	e	f	g	Ø h
S-250	38.1	18	24	27.5	95	77	8	9

Note! For dimensions on mounting possibilities K-250 refer to Chapter 3.

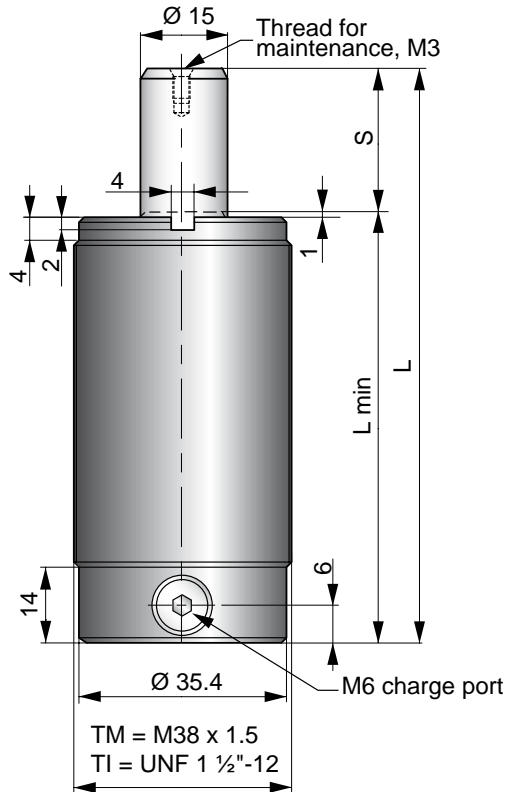

The TM and TI are threaded body 250 springs with the same length as the TU 250.

The TM spring has a metric thread M38 x 1.5.

The TI spring has an Inch thread UNF 1½-12.

Order No.	S Stroke	Force in N at 150 bar/+20°C		L ±0.25	L min	Gas vol. (l)	Weight (kg)
		Initial	End force*				
TM/TI 250-013	12.7	2650	3400	75.4	62.7	0.015	0.37
TM/TI 250-025	25		3400	100	75	0.024	0.42
TM/TI 250-038	38.1		3400	126.2	88.1	0.033	0.47
TM/TI 250-050	50		3400	150	100	0.042	0.52
TM/TI 250-064	63.5		3500	177	113.5	0.052	0.57
TM/TI 250-080	80		3500	210	130	0.063	0.64
TM/TI 250-100	100		3500	250	150	0.078	0.72

* = at full stroke

Basic Information

- For general information see "About gas springs", 2.1
- Pressure medium Nitrogen
- Max. charging pressure 150 bar
- Min. charging pressure 50 bar
- Operating temperature 0 to +80°C
- Force increase by temperature ±0.3%/°C
- Recommended max strokes/min ... ~ 80-100 (at 20°C)
- Max piston rod velocity 1.6 m/s

- Rod surface..... Nitrided
- Tube surface Black oxide
- Repair kit 2013691-0250

Mounting Possibilities

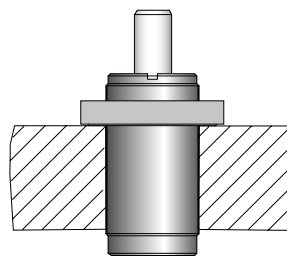

Lock Nut
FRM, FRI,
FHM, FHI

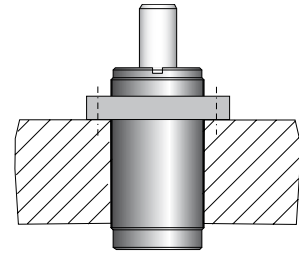

Top Mount
FTM, FTI

FRM/FRI

Order No.	Ø a	b	c	d	e
FRM-250	58	3.5	8	11	M38 x 1.5
FRI-250	58	3.5	8	11	UNF 1 ½-12

FHM/FHI

Order No.	a	b	c
FHM-250	47	M38 x 1.5	8
FHI-250	50.8	UNF 1 ½-12	8

FTM/FTI

Order No.	a
FTM-250	M38 x 1.5
FTI-250	UNF 1 ½-12

FTI - 250 *Being phased out!*



3

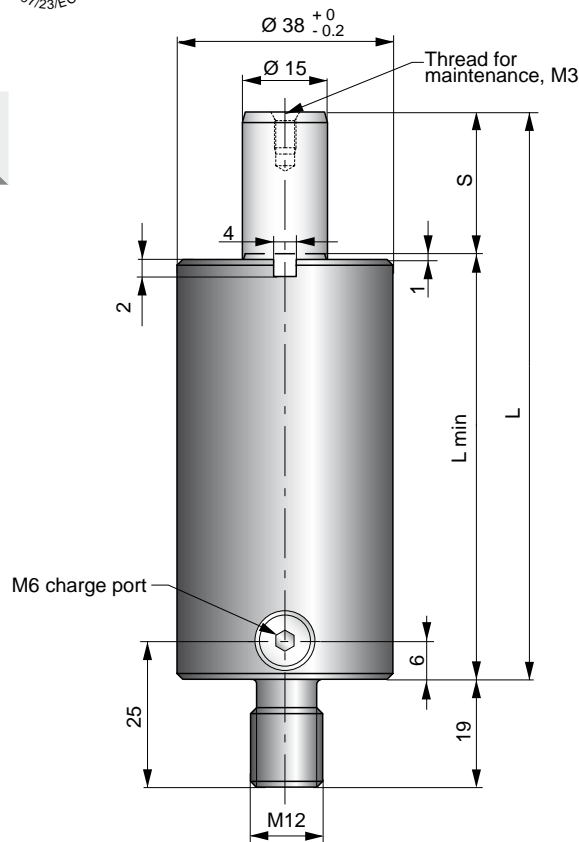

The TMS are 250 springs equipped with a threaded stud for mounting.

The TMS (Tube Metric Stud) has a M12 thread.

It has the same basic length as the TU 250 spring.

Order No.	S Stroke	Force in N at 150 bar/+20°C		L ±0.25	L min	Gas vol. (l)	Weight (kg)
		Initial	End force*				
TMS 250-013	12.7	2650	3400	75.4	62.7	0015	0.45
TMS 250-025	25		3400	100	75	0.024	0.50
TMS 250-038	38.1		3400	126.2	88.1	0.033	0.55
TMS 250-050	50		3400	150	100	0.042	0.60
TMS 250-064	63.5		3500	177	113.5	0.052	0.65
TMS 250-080	80		3500	210	130	0.063	0.70
TMS 250-100	100		3500	250	150	0.078	0.80

* = at full stroke

Basic Information

- For general information see "About gas springs", 2.1
- Pressure medium Nitrogen
- Max. charging pressure 150 bar
- Min. charging pressure 50 bar
- Operating temperature 0 to +80°C
- Force increase by temperature ±0.3%/°C
- Recommended max strokes/min ... ~ 80-100 (at 20°C)
- Max piston rod velocity 1.6 m/s
- Rod surface..... Nitrided
- Tube surface Black oxide
- Repair kit 2013691

Mounting Possibilities

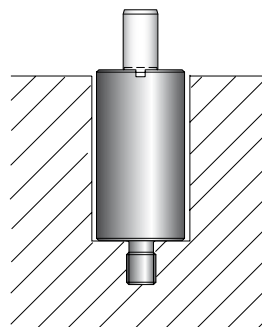

Thread Mount

Page intentionally left blank

Overview - $5000 \leq F_{INIT} < 7500$

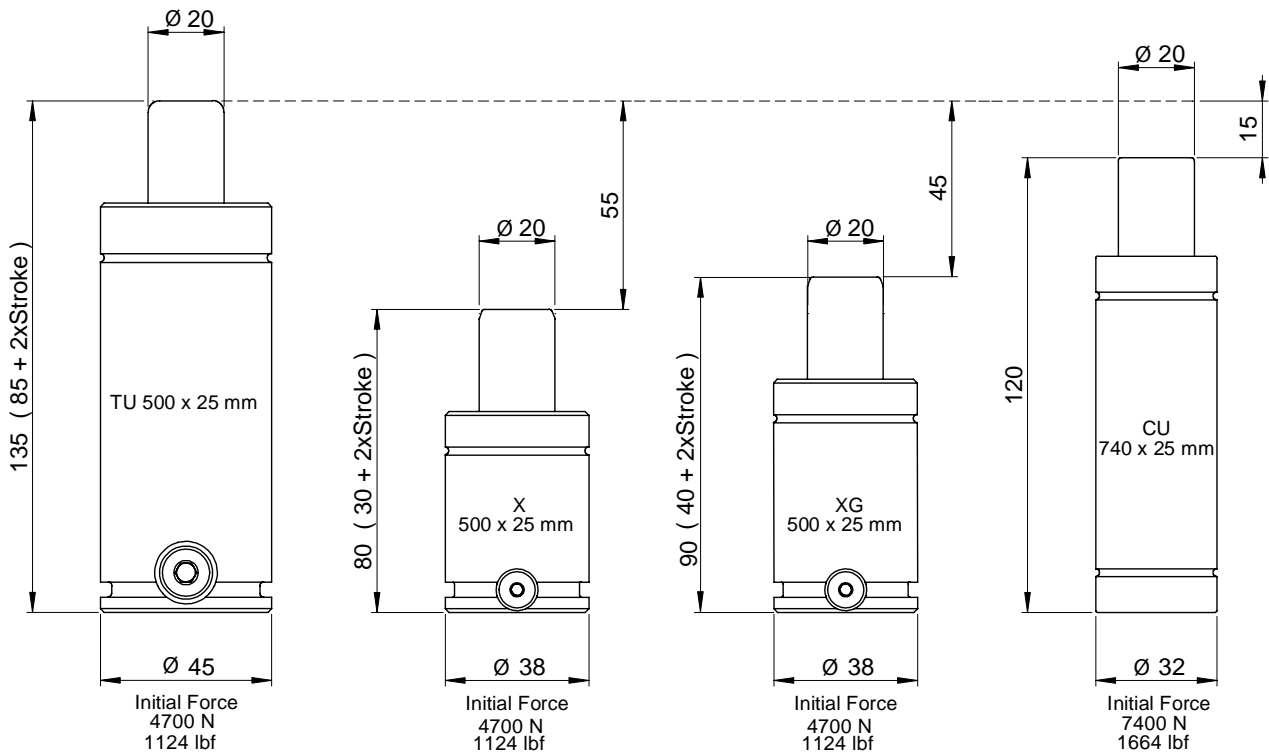
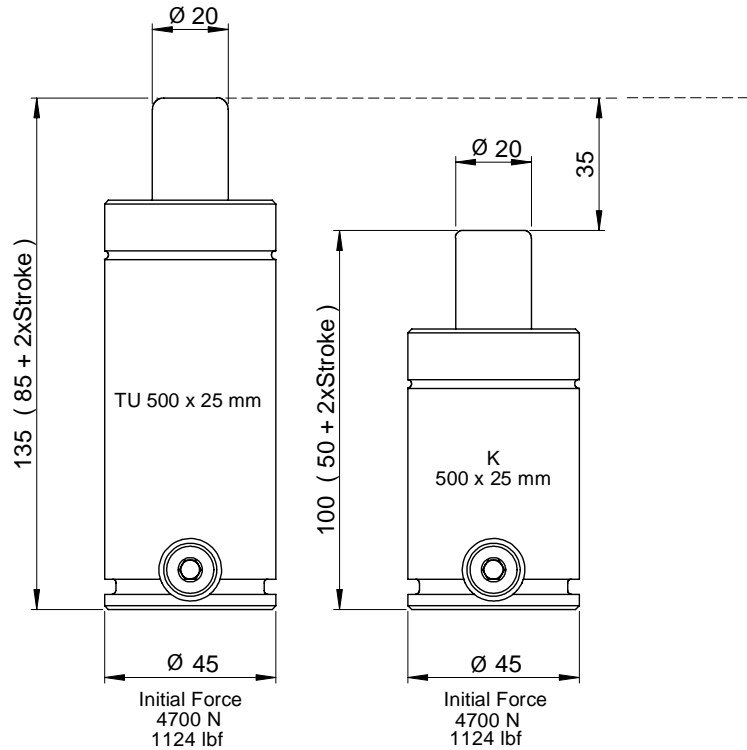

$5000 \leq F_{INIT} < 7500$

CU 740		Page 2.4/2
X 500		Page 2.4/4
XG 500		Page 2.4/6
K 500		Page 2.4/8
TU 500	 	Page 2.4/10

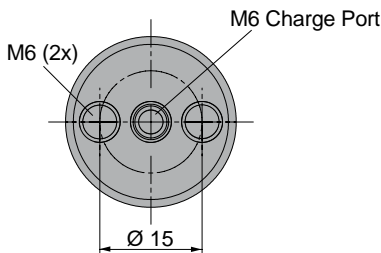
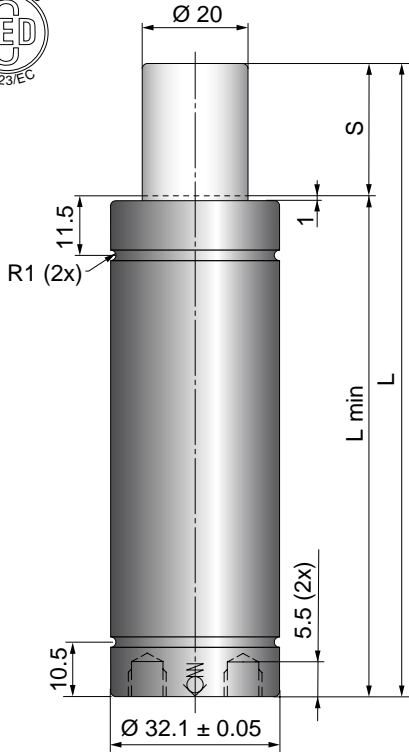

The CU gas springs are a very compact Bore Sealed gas spring, that gives a high force in a limited space.

Springs with stroke lengths over 25 mm should always be attached to the tool, using a flange or the tapped holes in the bottom of the spring. We also recommend shorter stroke springs to be fastened for optimal service-life.

Volvo Part No.	Order No.	S Stroke	Force in N at 150 bar/+20°C		L ±0.25	L min	Gas vol. (l)	Weight (kg)
			Initial	End force**				
3054663	CU 740-006	6	7400	9800	63	57	0.012	0.20
	CU 740-010	10		10000	75	65	0.017	0.24
3054664	CU 740-016	16		11000	93	77	0.024	0.28
3054665	CU 740-025	25		12000	120	95	0.034	0.33
3054666	CU 740-032	32*		12000	140	108	0.042	0.37
3054667	CU 740-040	40*		12000	165	125	0.052	0.42
3054668	CU 740-050	50*		12000	195	145	0.063	0.48

* = Should always be attached to the tool using the tapped holes in the bottom or a flange
 ** = at full stroke

Basic Information

For general information see "About gas springs", 2.1
 Pressure medium Nitrogen
 Max. charging pressure 150 bar (at 20° C)
 Min. charging pressure 25 bar (at 20° C)
 Operating temperature 0 to +80°C
 Force increase by temperature ±0.3%/°C
 Recommended max strokes/min ... ~ 50-100 (at 20°C)
 Max piston rod velocity 0.5 m/s

Rod surface..... Nitrided
 Tube surface Nitrided
 Repair kit Non-repairable

Mounting Possibilities

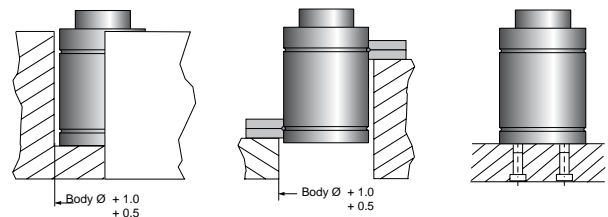

Drop - In

Top Mount
FC-MC

Base Mount
B

FC-MC

Order No. FC-MC-150

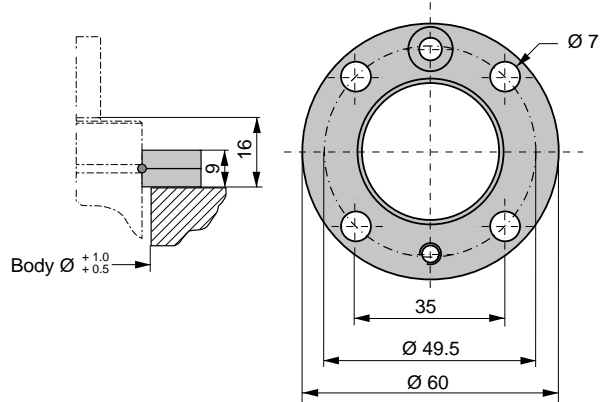
**FCS-32**

Order No. FCS-32

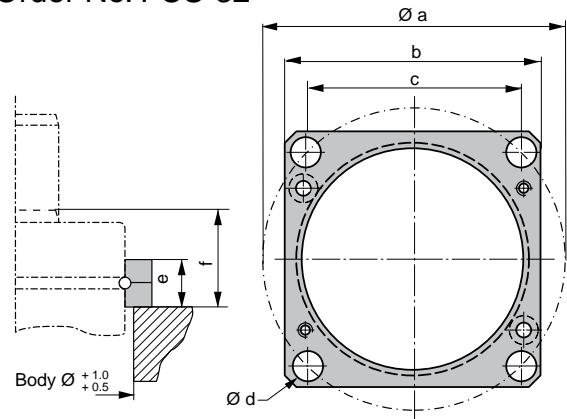

Order No.	$\varnothing a$	b	c	$\varnothing d$	e	f
FCS-32	49.5	45	35	7	9	16

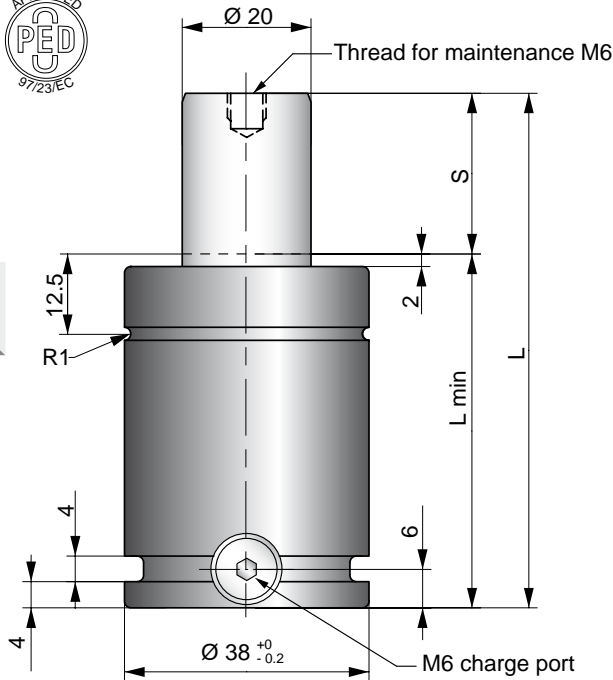

The Power Line series are our shortest and most powerful Piston Rod Sealed gas springs, giving you a great deal of force in a very small amount of space.

These gas springs are available with forces from 1700 N up to 200000 N and stroke lengths between 7 and 125 mm.

There is a side port for gas charging that can also be used to connect to a hose system.

An upper C-groove, lower U-groove together with two M6 threaded holes allow various mounting possibilities using our standard mounts.

4

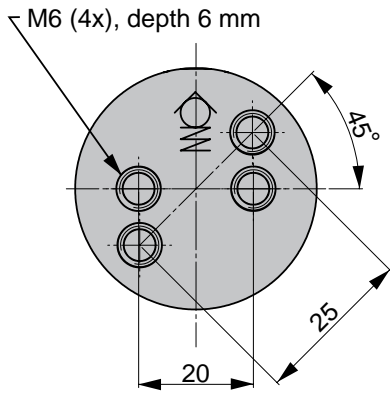

Volvo Part No.	Order No.	S Stroke	Force in Nat 150 bar/+20°C		L ±0.25	L min	Gas vol. (l)	Weight (kg)
			Initial	End force*				
3050743	X 500-010	10	4700	7200	50	40	0.01	0.25
3050744	X 500-013	13		7100	56	43	0.01	0.26
3050745	X 500-016	16		7200	62	46	0.02	0.27
3050746	X 500-019	19		7400	68	49	0.02	0.29
3050747	X 500-025	25		7300	80	55	0.03	0.31
3050748	X 500-032	32		7200	94	62	0.03	0.34
3050749	X 500-038	38		7200	106	68	0.04	0.36
3050750	X 500-050	50		7200	130	80	0.05	0.41
3050751	X 500-063	63		7200	156	93	0.06	0.46
3050752	X 500-075	75		7100	180	105	0.07	0.50
3050753	X 500-080	80		7100	190	110	0.08	0.52
3050754	X 500-100	100		7100	230	130	0.10	0.60
	X 500-125	125		7100	280	155	0.12	0.69

* = at full stroke

Basic Information

For general information see "About gas springs", 2.1
 Pressure medium Nitrogen
 Max. charging pressure 150 bar (at 20°C)
 Min. charging pressure 25 bar (at 20°C)
 Operating temperature 0 to +80°C
 Force increase by temperature ±0.3%/°C
 Recommended max strokes/min ... ~ 50 to 100 (at 20°C)
 Max piston rod velocity 1.6 m/s

Rod surface Nitrided
 Tube surface Black oxide
 Repair kit 3018846
 Repair kit 3050727

Mounting Possibilities

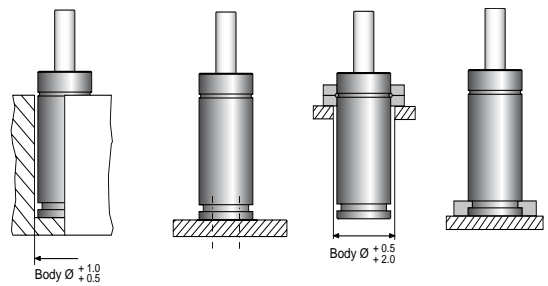

Drop - in Base Mount B Top Mount FC, FCS Foot Mount K, FFC

Note! For dimensions on mounting possibility K-500 refer to Chapter 3.

FC
ISO

Order No.	Ø a	Ø b	c	Ø d	e	f
FC-250	68	56.5	40	7	9	17

FCS
ISO

Volvo Part No.	Order No.	Ø a	b	c	Ø d	e	f
3044689	FCS-250	56.5	52	40	7	9	17

FFC
ISO

Volvo Part No.	Order No.	a	b	Ø c	Ø d	e	f
3050707	FFC-250	55	40	56.6	7	12	6.5

Note! For dimensions on mounting possibility K-500 refer to Chapter 3.

The Power Line series are our shortest and most powerful Piston Rod Sealed gas springs, giving you a great deal of force in a very small amount of space.

These gas springs are available with forces from 3500 N up to 66000 N and stroke lengths between 10 and 125 mm.

There is a side and a bottom port for gas charging that also can be used to connect to a hose system.

An upper C-groove, lower U-groove together with two M6 threaded holes allow various mounting possibilities using our standard mounts.

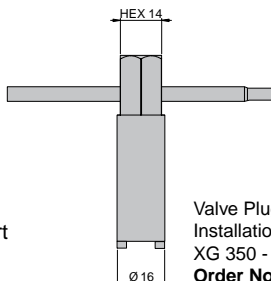
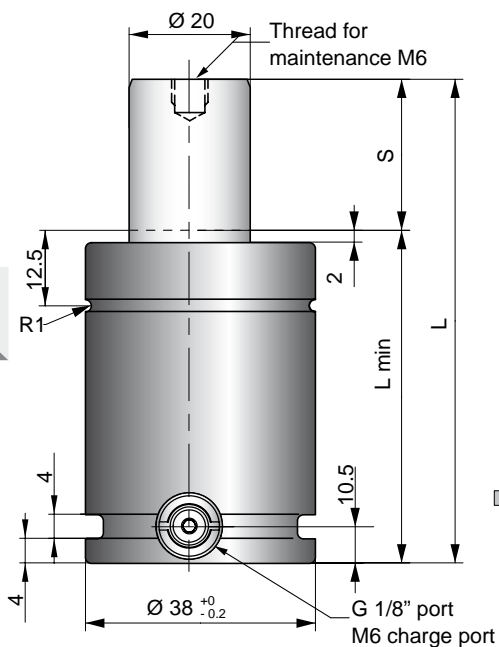

Valve Plug
Installation Tool,
XG 350 - XG 750
Order No. 3022974

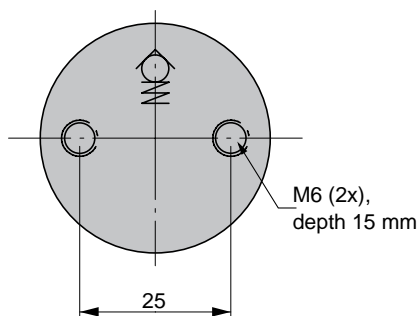

Order No.	S Stroke	Force in Nat 150 bar/+20°C		L ±0.25	L min	Gas vol. (l)	Weight (kg)
		Initial	End force*				
XG 500-010	10	4700	7200	60	50	0.01	0.33
XG 500-013	13		7100	66	53	0.01	0.34
XG 500-016	16		7200	72	56	0.02	0.36
XG 500-019	19		7400	78	59	0.02	0.37
XG 500-025	25		7300	90	65	0.03	0.39
XG 500-032	32		7200	104	72	0.03	0.42
XG 500-038	38		7200	116	78	0.04	0.44
XG 500-050	50		7200	140	90	0.05	0.49
XG 500-063	63		7200	166	103	0.06	0.54
XG 500-075	75		7100	190	115	0.07	0.58
XG 500-080	80		7100	200	120	0.08	0.60
XG 500-100	100		7100	2340	140	0.10	0.68
XG 500-125	125		7100	290	165	0.12	0.77

* = at full stroke

Basic Information

- For general information see "About gas springs", 2.1
- Pressure medium Nitrogen
- Max. charging pressure 150 bar (at 20°C)
- Min. charging pressure 25 bar (at 20°C)
- Operating temperature 0 to +80°C
- Force increase by temperature ±0.3%/°C
- Recommended max strokes/min ... ~ 50 to 100 (at 20°C)
- Max piston rod velocity 1.6 m/s

- Rod surface Nitrided
- Tube surface Black oxide
- Repair kit 3018846

Mounting Possibilities

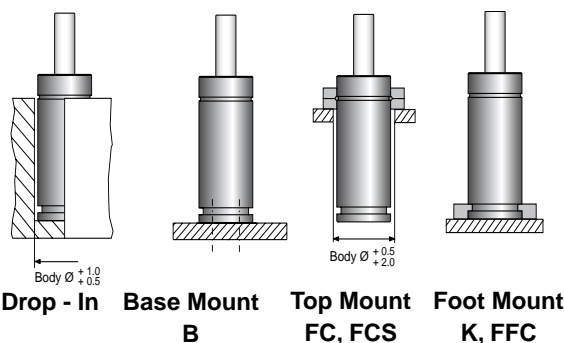

Note! For dimensions on mounting possibility K refer to chapter 3.

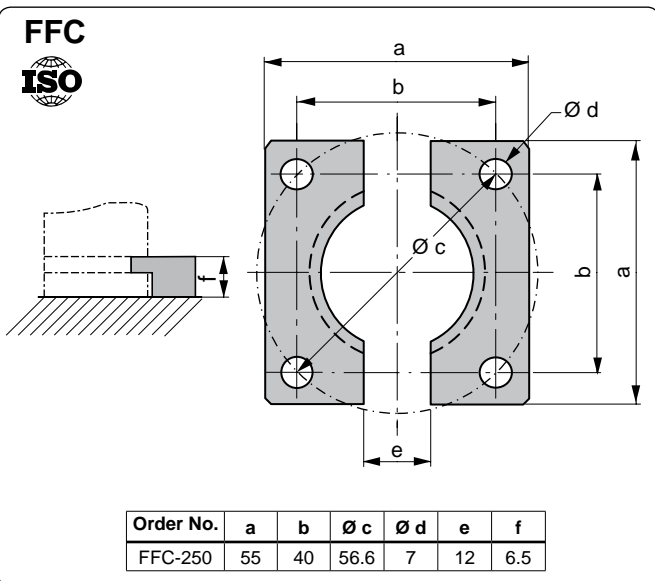
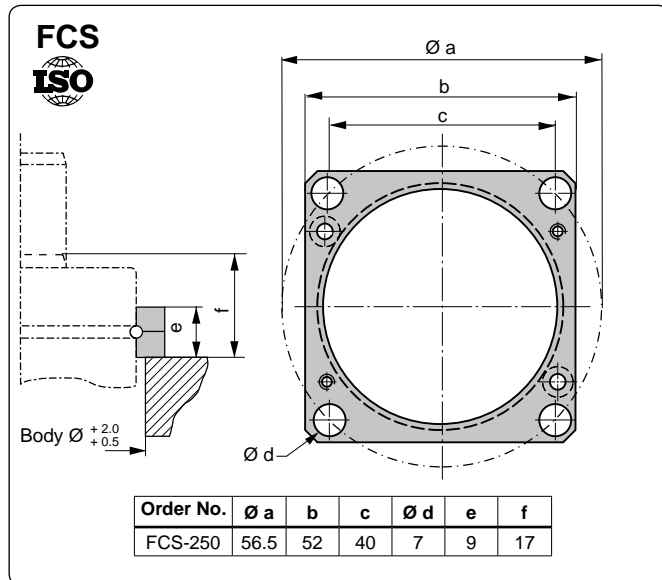
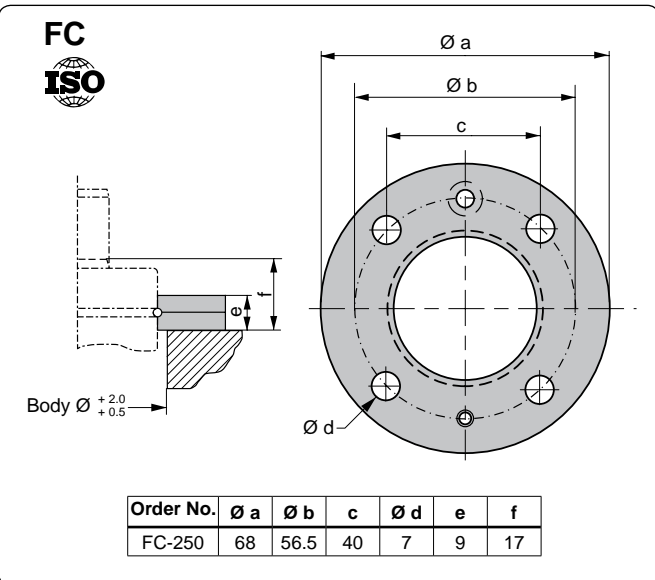

Note! For dimensions on mounting possibility K refer to chapter 3.



This is a short height hoseable spring with an initial force of 4700 N.

The K 500 has a total length of 50 mm + (2 x stroke). This spring is 35 mm shorter than the TU 500. Mounting options are the same as for the TU 500.

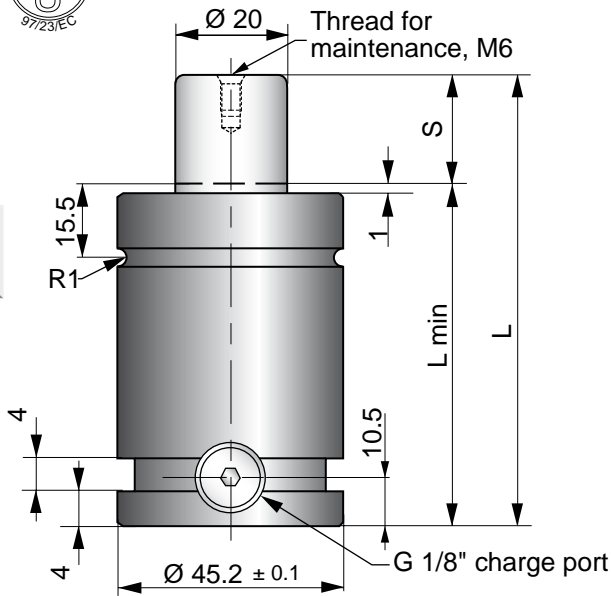

4

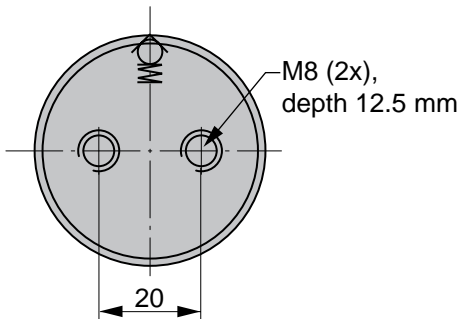

Order No.	S Stroke	Force in N at 150 bar/+20°C		L ±0.25	L min	Gas vol. (l)	Weight (kg)
		Initial	End force*				
K 500-006	6	4700	5600	62	56	0.02	0.50
K 500-013	12.7		5900	75.4	62.7	0.03	0.54
K 500-019	19		6100	88.1	69.05	0.04	0.59
K 500-025	25		6100	100	75	0.04	0.62
K 500-038	38.1		6200	126.2	88.1	0.06	0.71
K 500-050	50		6300	150	100	0.07	0.78
K 500-064	63.5		6300	177	113.5	0.09	0.88
K 500-080	80		6600	210	130	0.11	0.98
K 500-100	100		6600	250	150	0.12	1.12
K 500-125	125		6600	300	175	0.15	1.28

* = at full stroke

Basic Information

For general information see "About gas springs", 2.1
 Pressure medium Nitrogen
 Max. charging pressure 150 bar
 Min. charging pressure 25 bar
 Operating temperature 0 to +80°C
 Force increase by temperature ±0.3t 20°C)
 Recommended max strokes/min ... ~ 40 - 80 (at 20°C)
 Max piston rod velocity 1.6 m/s

Rod surface..... Nitrided
 Tube surface Black oxide
 Repair kit 3017230-0500

Mounting Possibilities

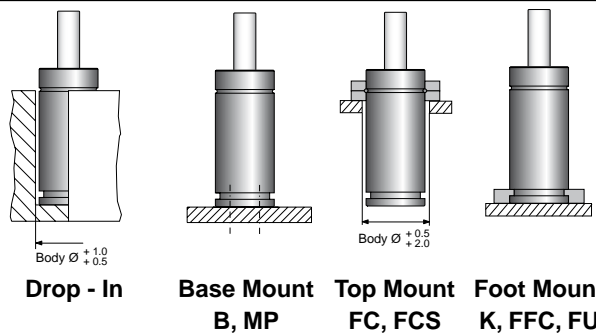

Note! For dimensions on mounting possibilities K-500 and FU-500 refer to Chapter 3.

MP
ISO

Note! Comes complete with screws to mount gas spring.

Order No.	a	b
MP-500	70	50

FC
ISO

Order No.	Ø a	Ø b	c	Ø d	e	f
FC-500	86	70.7	50	9	13	22

4

FCS
ISO

Order No.	Ø a	b	c	Ø d	e	f
FCS-500	70.7	64	50	9	13	22

FFC
ISO

Order No.	a	b	Ø c	Ø d	e	f
FFC-500	70	50	70.7	9	20	6.5

Note! For dimensions on mounting possibilities K-500 and FU-500 refer to Chapter 3.



4

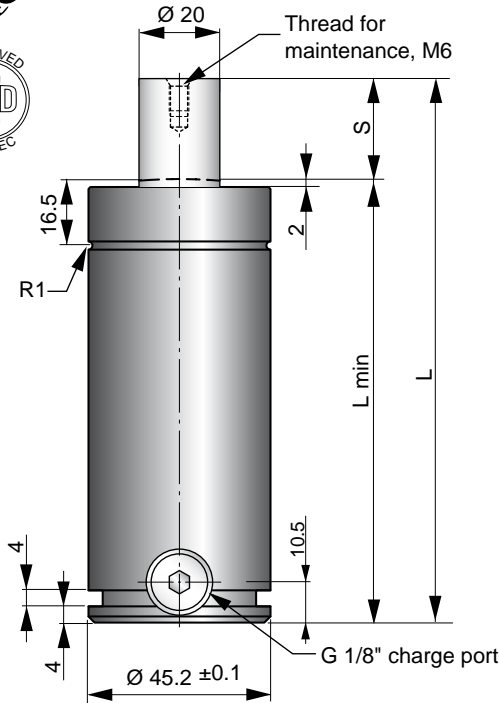

The standard line of gas springs is the TU- line. Sizes 250 to 10000 correspond to the ISO 11901 standard for gas springs.

The TU 500 has a total length of 85 mm + (2 x stroke).

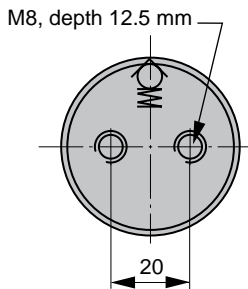

Volvo Part No.	Order No.	S Stroke	Force in N at 150 bar/+20°C		L ±0.25	L min	Gas vol. (l)	Weight (kg)	ISO 11901
			Initial	End force*					
	TU 500-010	10	4700	6000	105	95	0.023	0.93	
3044177	TU 500-013	12.7		6100	110.4	97.7	0.025	0.95	
3044178	TU 500-025	25		6400	135	110	0.038	1.04	✓
3044179	TU 500-038	38.1		6500	161.2	123.1	0.051	1.13	
3044180	TU 500-050	50		6600	185	135	0.063	1.21	✓
3044181	TU 500-064	63.5		6600	212	148.5	0.077	1.31	
3044182	TU 500-080	80		6700	245	165	0.093	1.43	✓
3044183	TU 500-100	100		6700	285	185	0.114	1.57	
	TU 500-125	125		6700	335	210	0.139	1.74	
	TU 500-160	160		6700	405	245	0.175	1.99	

* = at full stroke

Basic Information

- For general information see "About gas springs", 2.1
- Pressure medium Nitrogen
- Max. charging pressure 150 bar
- Min. charging pressure 25 bar
- Operating temperature 0 to +80°C
- Force increase by temperature ±0.3%/°C
- Recommended max strokes/min ... ~ 40-80 (at 20°C)
- Max piston rod velocity 1.6 m/s

- Rod surface..... Nitrided
- Tube surface Black oxide
- Repair kit 2013691
- Repair kit 3044226

Mounting Possibilities

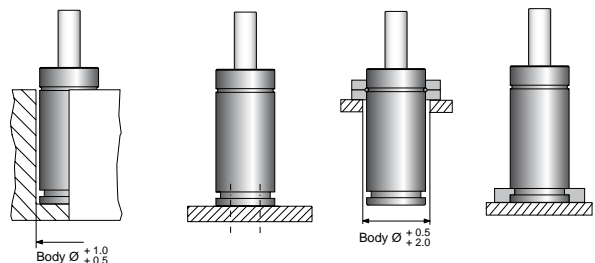

Drop - In **Base Mount** **Top Mount** **Foot Mount**
 B, MP FC, FCS K, FFC, FU

Note! For dimensions on mounting possibilities K-500 and FU-500 refer to Chapter 3.

MP
ISO

Note! Comes complete with screws to mount gas spring.

Order No.	a	b
MP-500	70	50

FC
ISO

Order No.	Ø a	Ø b	c	Ø d	e	f
FC-500	86	70.7	50	9	13	23

FCS
ISO

Volvo Part No.	Order No.	Ø a	b	c	Ø d	e	f
3044690	FCS-500	70.7	64	50	9	13	23

FFC
ISO

Order No.	a	b	Ø c	Ø d	e	f
FFC-500	70	50	70.7	9	20	6.5

Note! For dimensions on mounting possibilities K-500 and FU-500 refer to Chapter 3.

S
ISO

Note! Support S is designed to be used in combination with flanges mounted in the U or C groove or mount option B.







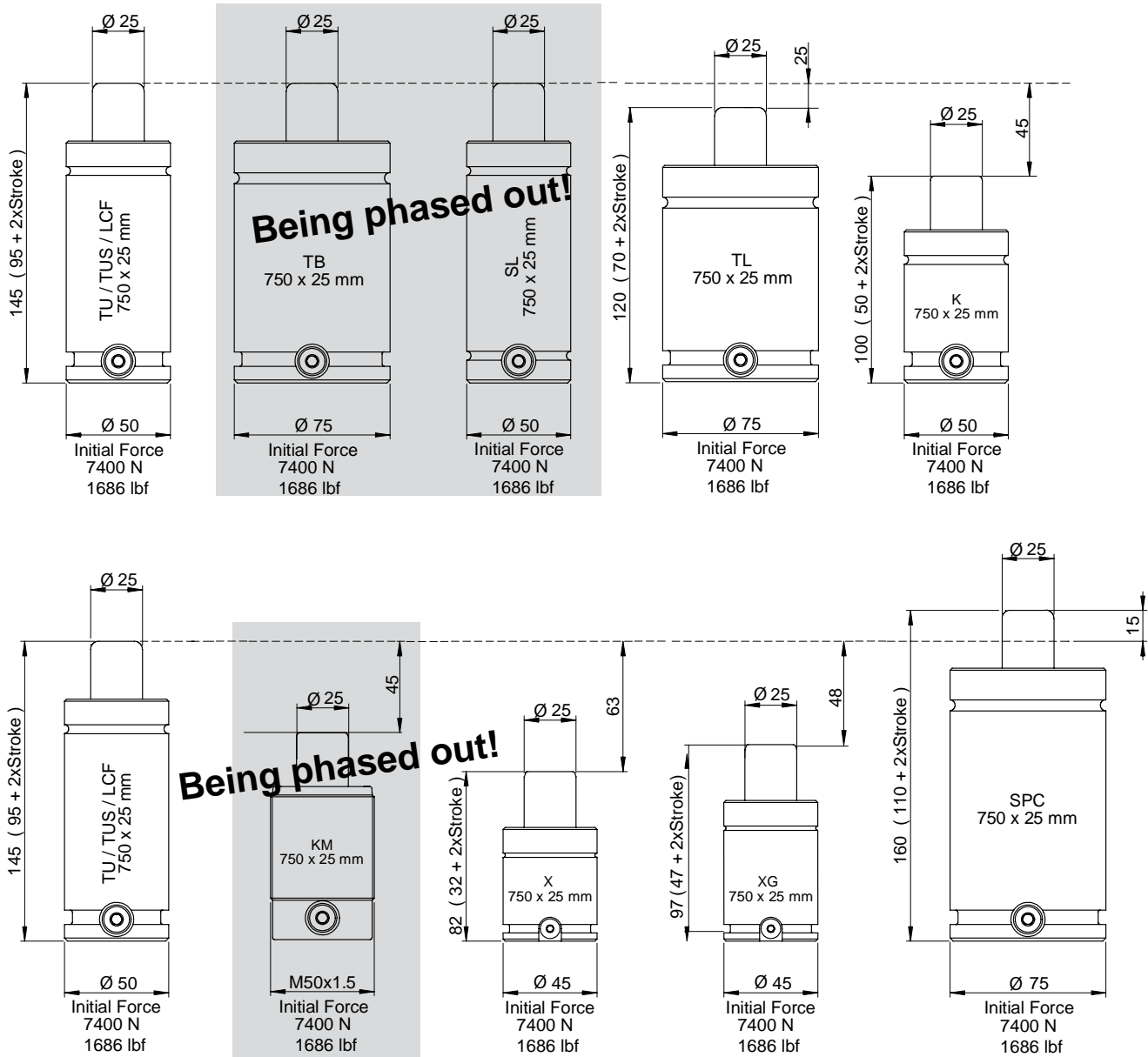





The mounting screw (M8) should be tightened with torque 25 Nm.

Order No.	Ø a	b	c	d	e	f	g	Ø h
S-500	45.4	17	29	30	100	82	9	9

Overview - $7500 \leq F_{INIT} < 10000$



7500 ≤ F_{INIT} < 10000

X 750		Page 2.5/2
XG 750		Page 2.5/4
TL 750		Page 2.5/6
K 750		Page 2.5/8
KM 750	<i>Being phased out!</i> 	Page 2.5/10
TU 750	 	Page 2.5/12
TUS 750		Page 2.5/14
LCF 750		Page 2.5/16
TB 750	<i>Being phased out!</i> 	Page 2.5/18
SL 750	<i>Being phased out!</i> 	Page 2.5/20
SPC 750		Page 2.5/22

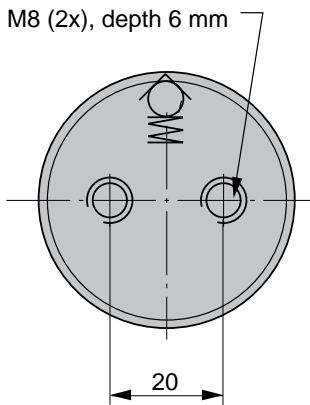
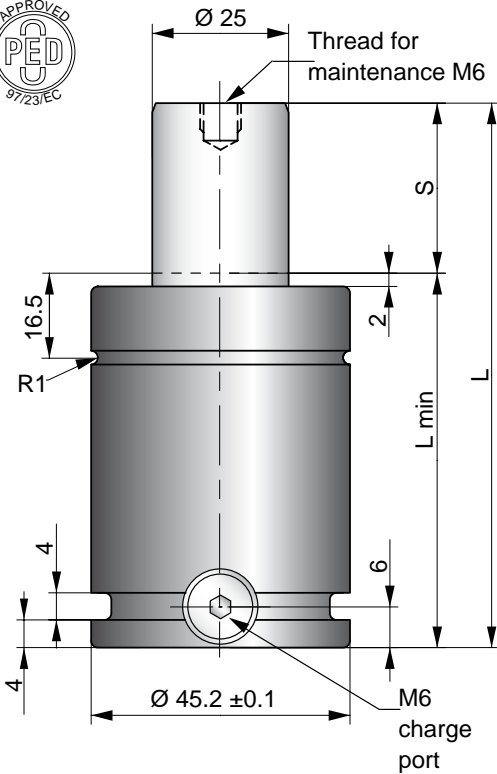

The Power Line series are our shortest and most powerful Piston Rod Sealed gas springs, giving you a great deal of force in a very small amount of space.

These gas springs are available with forces from 1700 N up to 200000 N and stroke lengths between 7 and 125 mm.

There is a side port for gas charging that can also be used to connect to a hose system.

An upper C-groove, lower U-groove together with two M8 threaded holes allow various mounting possibilities using our standard mounts.

Order No.	S Stroke	Force in N at 150 bar/+20°C		L ±0.25	L min	Gas vol. (l)	Weight (kg)
		Initial	End force*				
X 750-010	10	7400	12100	52	42	0.02	0.37
X 750-013	13		12100	58	45	0.02	0.39
X 750-016	16		12100	64	48	0.03	0.41
X 750-019	19		11700	70	51	0.03	0.41
X 750-025	25		11800	82	57	0.04	0.45
X 750-032	32		11800	96	64	0.05	0.50
X 750-038	38		11800	108	70	0.05	0.53
X 750-050	50		11800	132	82	0.07	0.61
X 750-063	63		11800	158	95	0.09	0.69
X 750-075	75		11900	182	107	0.10	0.77
X 750-080	80		11900	192	112	0.11	0.80
X 750-100	100		11900	232	132	0.13	0.93
X 750-125	125		11900	282	157	0.17	1.09

* = at full stroke

Basic Information

- For general information see "About gas springs", 2.1
- Pressure medium Nitrogen
- Max. charging pressure 150 bar (at 20°C)
- Min. charging pressure 25 bar (at 20°C)
- Operating temperature 0 to +80°C
- Force increase by temperature ±0.3%/°C
- Recommended max strokes/min ... ~ 50 to 100 (at 20°C)
- Max piston rod velocity 1.6 m/s
- Rod surface Nitrided
- Tube surface Black oxide
- Repair kit 3019903

Mounting Possibilities

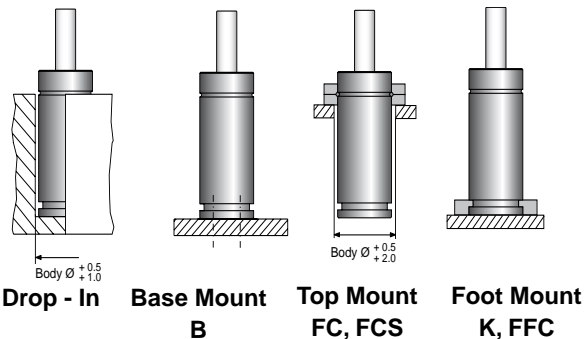

Note! For dimensions on mounting possibility K-750 and FU-750 refer to Chapter 3.

FC
ISO

Order No.	Ø a	Ø b	c	Ø d	e	f
FC-500	86	70.7	50	9	13	23

FCS
ISO

Order No.	Ø a	b	c	Ø d	e	f
FCS-500	70.7	64	50	9	13	23

FFC
ISO

Order No.	a	b	Ø c	Ø d	e	f
FFC-500	70	50	70.7	9	20	6.5

Note! For dimensions on mounting possibility K-750 and FU-750 refer to Chapter 3.

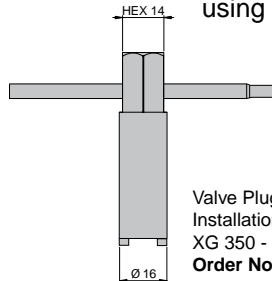
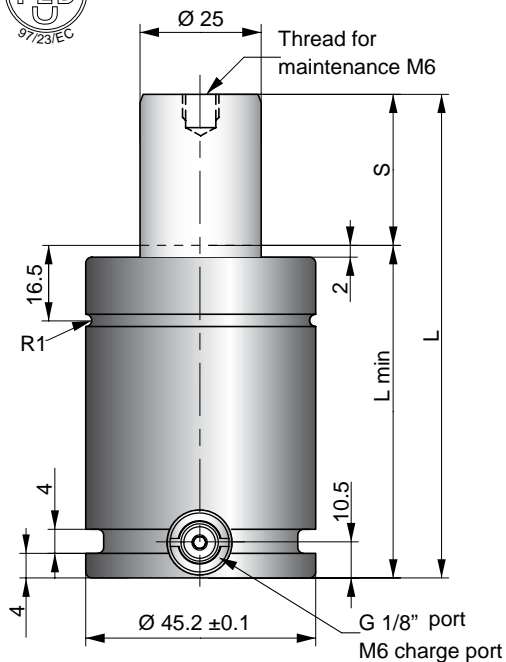

Valve Plug
Installation Tool,
XG 350 - XG 750
Order No. 3022974

The Power Line series are our shortest and most powerful Piston Rod Sealed gas springs, giving you a great deal of force in a very small amount of space.

These gas springs are available with forces from 3500 N up to 66000 N and stroke lengths between 10 and 125 mm.

There is a side and a bottom port for gas charging that can also be used to connect to a hose system.

An upper C-groove, lower U-groove together with two M8 threaded holes allow various mounting possibilities using our standard mounts.

5

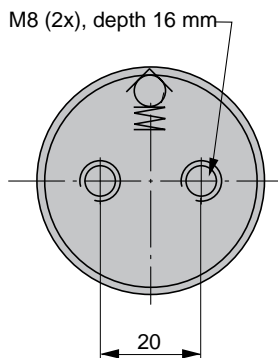

Order No.	S Stroke	Force in N at 150 bar/+20°C		L ±0.25	L min	Gas vol. (l)	Weight (kg)
		Initial	End force*				
XG 750-010	10	7400	12100	67	57	0.02	0.55
XG 750-013	13		12100	73	60	0.02	0.55
XG 750-016	16		12100	79	63	0.03	0.57
XG 750-019	19		11700	85	66	0.03	0.58
XG 750-025	25		11800	97	72	0.04	0.62
XG 750-032	32		11800	111	79	0.05	0.66
XG 750-038	38		11800	123	85	0.05	0.70
XG 750-050	50		11800	147	97	0.07	0.78
XG 750-063	63		11800	173	110	0.09	0.86
XG 750-075	75		11900	197	122	0.10	0.93
XG 750-080	80		11900	207	127	0.11	0.97
XG 750-100	100		11900	247	147	0.13	1.09
XG 750-125	125		11900	297	172	0.17	1.25

* = at full stroke

Basic Information

- For general information see "About gas springs", 2.1
- Pressure medium Nitrogen
- Max. charging pressure 150 bar (at 20°C)
- Min. charging pressure 25 bar (at 20°C)
- Operating temperature 0 to +80°C
- Force increase by temperature ±0.3%/°C
- Recommended max strokes/min ... ~ 50 to 100 (at 20°C)
- Max piston rod velocity 1.6 m/s
- Rod surface Nitrided
- Tube surface Black oxide
- Repair kit 3019903

Mounting Possibilities

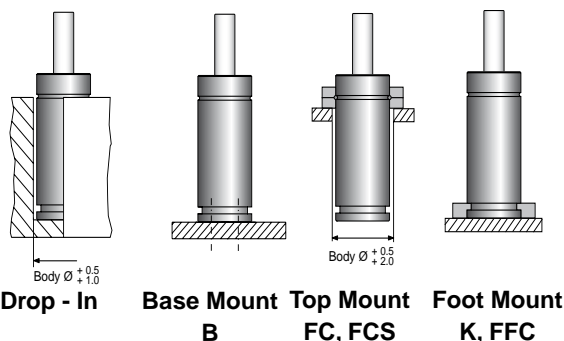

Note!
For dimensions on mounting possibility K and FU refer to chapter 3.

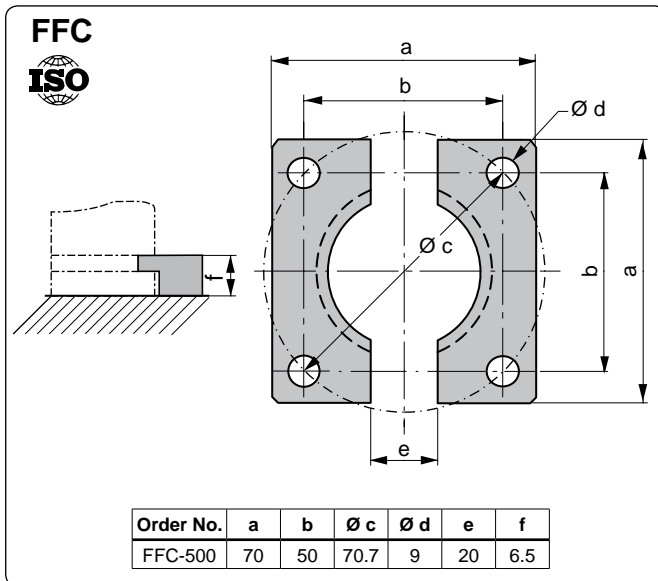
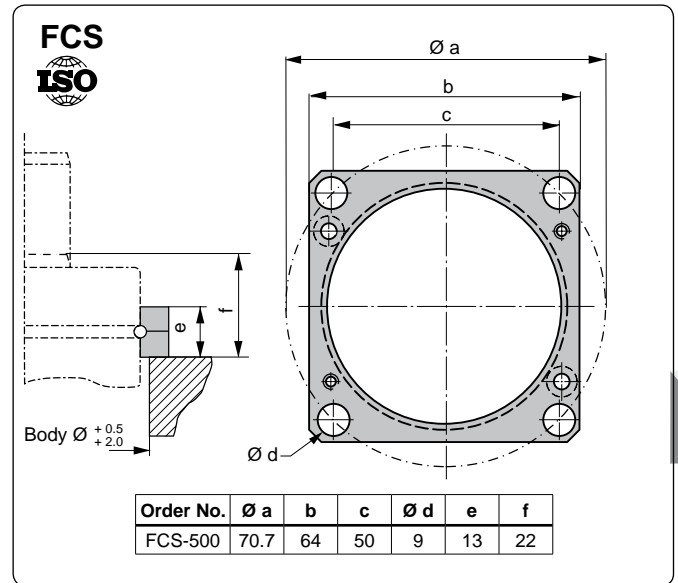
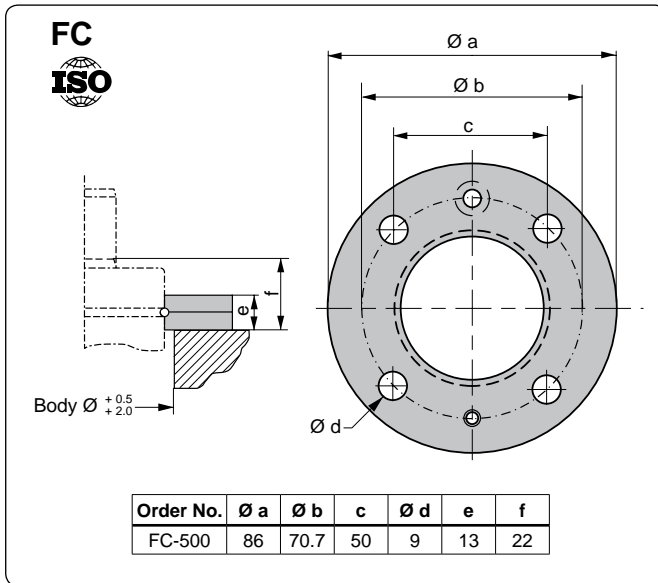

Note! For dimensions on mounting possibility K and FU refer to chapter 3.

The TL series ranges from model sizes 750 to 5000, with the same features and technology as the TU series.

At the same time, the TL gas spring is shorter than the corresponding TU gas spring by 25 mm, except TL 5000 which is 37.5 mm shorter. TL springs share the same TU mounting possibilities and stroke lengths, with exception of strokes 12.5, 37.5 and 62.5.

5

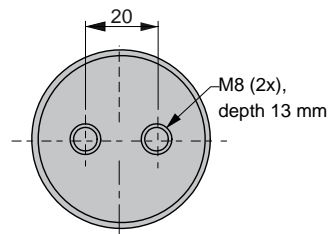
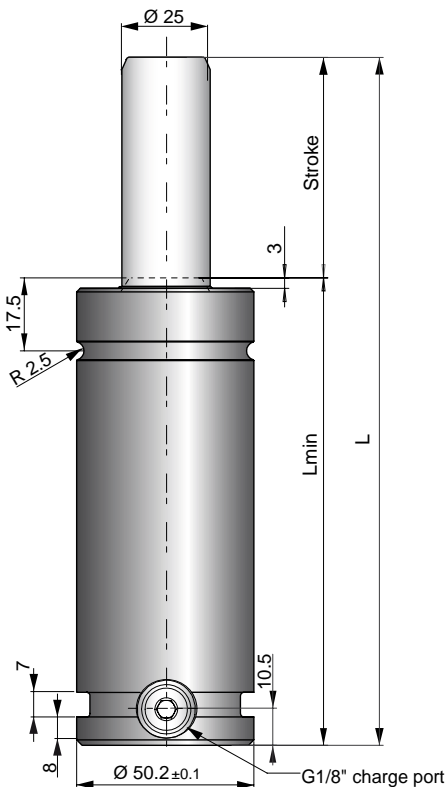

Order No.	S Stroke	Force in N at 150 bar/+20°C		L ±0.25	L min	Gas vol. (l)	Weight (kg)
		Initial	End force*				
TL750-013	12.5		11400	95	82.5	0.03	0.97
TL 750-025	25		11700	120	95	0.04	1.08
TL 750-038	37.5		11800	145	107.5	0.06	1.20
TL 750-050	50		11900	170	120	0.08	1.32
TL 750-063	62.5		11900	195	132.5	0.09	1.42
TL 750-075	75		11900	220	145	0.31	1.53
TL 750-080	80		11900	230	150	0.11	1.58
TL 750-086	87.5		11900	245	157.5	0.35	1.65
TL 750-100	100		11900	270	170	0.14	1.77
TL 750-113	112.5	7300	12000	295	182.5	0.43	1.89
TL 750-125	125		12000	320	195	0.15	2.01
TL 750-138	137.5		12000	345	207.5	0.17	2.13
TL 750-150	150		12000	370	220	0.19	2.25
TL 750-160	160		12000	390	230	0.20	2.34
TL 750-175	175		12000	420	245	0.23	2.48
TL 750-200	200		12000	470	270	0.26	2.72
TL 750-225	225		12000	520	295	0.30	2.96
TL 750-250	250		12000	570	320	0.33	3.19

* = at full stroke

Basic Information

- For general information see "About gas springs", 2.1
- Pressure medium Nitrogen
- Max. charging pressure 150 bar
- Min. charging pressure..... 25 bar
- Operating temperature 0 to +80°C
- Force increase by temperature ±0.3%/°C
- Recommended max strokes/min ~ 15-40 (at 20°C)
- Max piston rod velocity 1.6 m/s
- Rod surface..... Nitrided
- Tube surface Black oxide
- Repair kits
- TL 750 3024118

Mounting Possibilities

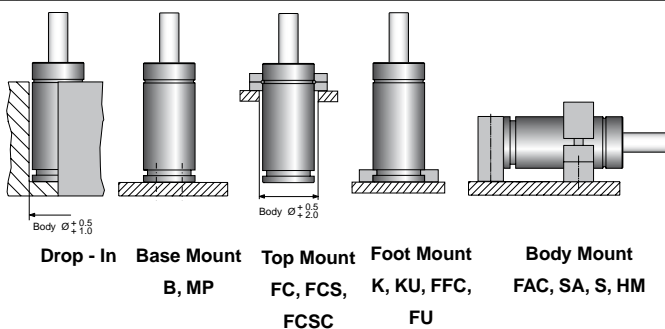

Note! For dimensions on mounting possibilities K-750, KU-750, FU-750, FAC-750, SA-750 and FCSC-750 refer to Chapter 3.

MP
ISO

Technical drawing of the MP ISO mount. The cross-section shows a central hole with diameter $\varnothing 9$ (2x), a total width of $\varnothing 15$ (2x), and a height of 12. The top view shows a square shape with side length $\varnothing 20$, four M10 mounting holes, and dimensions a and b for the hole spacing. Section line A-A is indicated.

Note! Comes complete with screws to mount gas spring.

Order No.	a	b
MP-750	75	56.5

FC
ISO

Technical drawing of the FC ISO mount. The cross-section shows a body with diameter \varnothing and a hole with diameter \varnothing . The top view shows a circular shape with outer diameter $\varnothing a$, inner diameter $\varnothing b$, and hole spacing c and $\varnothing d$. The body diameter tolerance is $+0.5$ / $+2.0$.

Order No.	$\varnothing a$	$\varnothing b$	c	$\varnothing d$	e	f
FC-750	95	80	56.5	9	13	24

FCS
ISO

Technical drawing of the FCS ISO mount. The cross-section shows a body with diameter \varnothing and a hole with diameter \varnothing . The top view shows a square shape with outer diameter $\varnothing a$, inner diameter $\varnothing b$, and hole spacing c and $\varnothing d$. The body diameter tolerance is $+0.5$ / $+2.0$.

Order No.	$\varnothing a$	b	c	$\varnothing d$	e	f
FCS-750	80	70	56.5	9	13	24

FFC
ISO

Technical drawing of the FFC ISO mount. The cross-section shows a body with diameter \varnothing and a hole with diameter \varnothing . The top view shows a U-shaped profile with dimensions a , b , $\varnothing c$, $\varnothing d$, e , and f .

Order No.	a	b	$\varnothing c$	$\varnothing d$	e	f
FFC-750	75	56.5	80	9	24	12

S
ISO

Technical drawing of the S ISO support. The cross-section shows a support with a central hole of diameter $\varnothing a$, a mounting screw, and dimensions b , c , d , e , and f . The top view shows a rectangular shape with dimensions g and $\varnothing h$.

Note! Support S is designed to be used in combination with flanges mounted in the U or C groove or mount option B.

The mounting screw (M8) should be tightened with torque 25 Nm.

Order No.	$\varnothing a$	b	c	d	e	f	g	$\varnothing h$
S-750	50.4	20	40	40	130	110	10	9

Note! For dimensions on mounting possibilities K-750, KU-750, FU-750, FAC-750, SA-750 and FCSC-750, refer to Chapter 3.



This is a short height hoseable spring with an initial force of 7400 N.

The K 750 has a total length of 50 mm + (2 x stroke). This spring is 45 mm shorter than the TU 750. Mounting options are the same as for the TU 750.

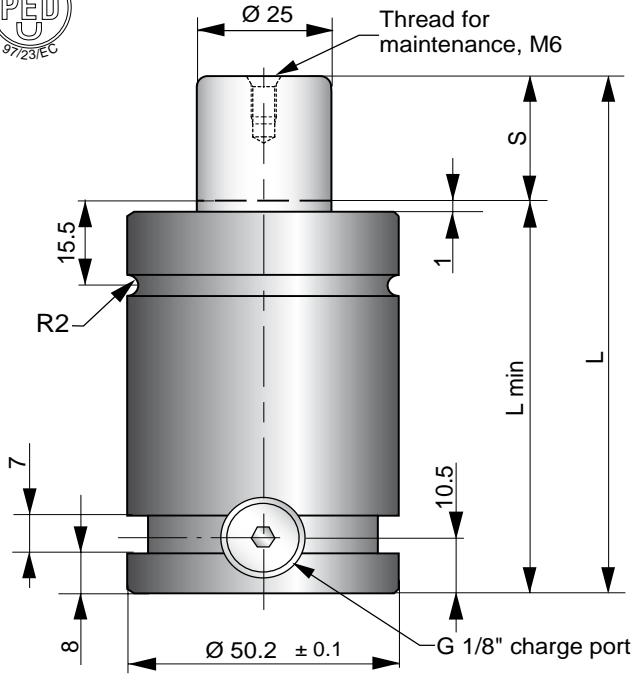

M8 (2x), depth 12.5 mm

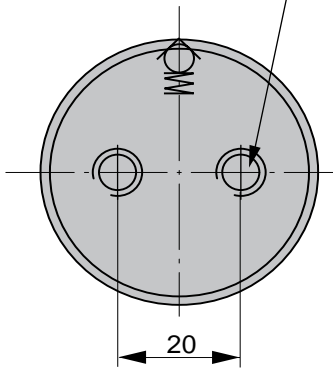

Order No.	S Stroke	Force in N at 150 bar/+20°C		L ±0.25	L min	Gas vol. (l)	Weight (kg)
		Initial	End force*				
K 750-006	6	7400	15000	62	56	0.01	0.68
K 750-013	12.7	7400	13000	75.4	62.7	0.02	0.73
K 750-019	19	7400	12000	88.1	69.05	0.03	0.80
K 750-025	25	7400	11000	100	75	0.04	0.82
K 750-038	38.1	7400	11000	126.2	88.1	0.06	0.92
K 750-050	50	7400	11000	150	100	0.08	1.06
K 750-064	63.5	7400	11000	177	113.5	0.10	1.12
K 750-080	80	7400	11000	210	130	0.12	1.26
K 750-100	100	7400	11000	250	150	0.15	1.39
K 750-125	125	7400	11000	300	175	0.19	1.57

* = at full stroke

Basic Information

- For general information see "About gas springs", 2.1
- Pressure medium Nitrogen
- Max. charging pressure 150 bar
- Min. charging pressure 25 bar
- Operating temperature 0 to +80°C
- Force increase by temperature ±0.3%/°C
- Recommended max strokes/min ... ~ 15-40 (at 20°C)
- Max piston rod velocity 1.6 m/s

- Rod surface..... Nitrided
- Tube surface Black oxide
- Repair kit 3017230

Mounting Possibilities

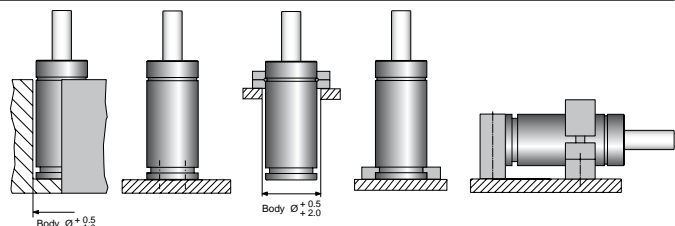

- Drop - In**
- Base Mount**
B, MP
- Top Mount**
FC, FCS, FCSC
- Foot Mount**
K, KU, FFC, FU
- Body Mount**
FAC, SA, S

Note! For dimensions on mounting possibilities K-750, KU-750, FU-750, FAC-750, SA-750 and FCSC-750 refer to Chapter 3.

MP
ISO

Note! Comes complete with screws to mount gas spring.

Order No.	a	b
MP-750	75	56.5

FC
ISO

Order No.	Ø a	Ø b	c	Ø d	e	f
FC-750	95	80	56.5	9	13	22

FCS
ISO

Order No.	Ø a	b	c	Ø d	e	f
FCS-750	80	70	56.5	9	13	22

FFC
ISO

Order No.	a	b	Ø c	Ø d	e	f
FFC-750	75	56.5	80	9	24	12

S
ISO

Note! Support S is designed to be used in combination with flanges mounted in the U or C groove or mount option B.

The mounting screw (M8) should be tightened with torque 25 Nm.

Order No.	Ø a	b	c	d	e	f	g	Ø h
S-750	50.4	20	40	40	130	110	10	9

Note! For dimensions on mounting possibilities K-750, KU-750, FU-750, FAC-750, SA-750 and FCSC-750, refer to Chapter 3.

KM 750

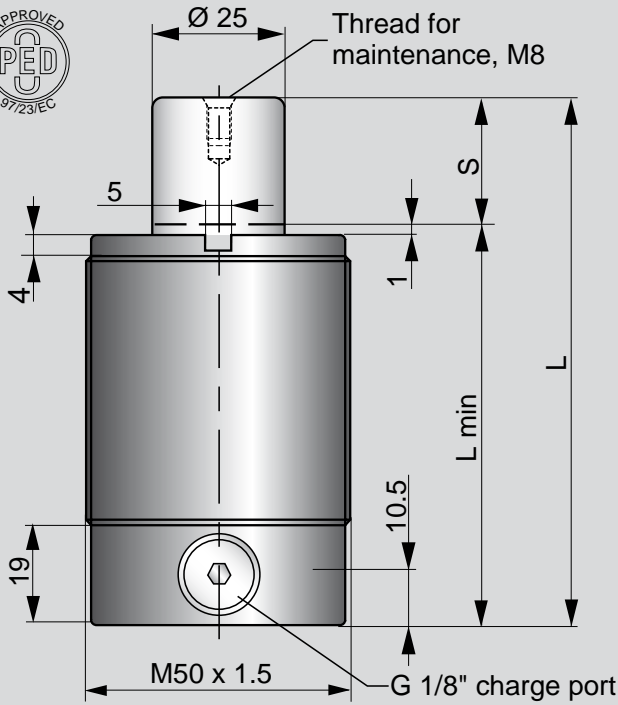

The KM 750 is a threaded body version of the K 750.
 All internal components and technical data are the same as for the K 750.
 Dimensions according to the FORD standard.

5

Being phased out!

M8 (2x), depth 12.5 mm

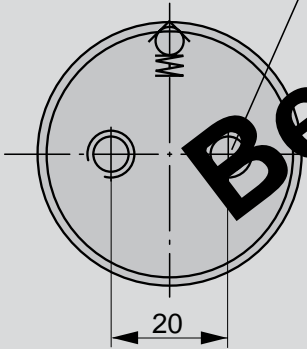

Order No.	S Stroke	Force in N at 150 bar/+20°C		L ±0.25	L min	Gas vol. (l)	Weight (kg)
		Initial	End force*				
KM 750-006	6	7400	15000	62	56	0.01	0.68
KM 750-013	12.7		13000	75.4	62.7	0.02	0.73
KM 750-019	19		12000	88.1	69.05	0.03	0.80
KM 750-025	25		11000	100	75	0.04	0.82
KM 750-038	38.1		11000	126.2	88.1	0.06	0.92
KM 750-050	50		11000	150	100	0.08	1.06
KM 750-064	63.5		11000	177	113.5	0.10	1.12
KM 750-080	80		11000	210	130	0.12	1.26
KM 750-100	100		11000	250	150	0.15	1.39
KM 750-125	125		11000	300	175	0.19	1.57

* = at full stroke

* = at full stroke

Basic Information

- For general information see "About gas springs", 2.1
- Pressure medium Nitrogen
- Max. charging pressure 150 bar
- Min. charging pressure 25 bar
- Operating temperature 0 to +80°C
- Force increase by temperature ±0.3%/°C
- Recommended max strokes/min ... ~ 15-40 (at 20°C)
- Max piston rod velocity 1.6 m/s

- Rod surface..... Nitrided
- Tube surface Black oxide
- Repair kit 3017230-0750

Mounting Possibilities

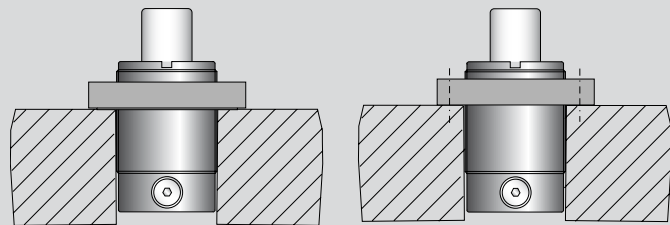

Lock nut
FRM

Top Mount
FTM

FRM

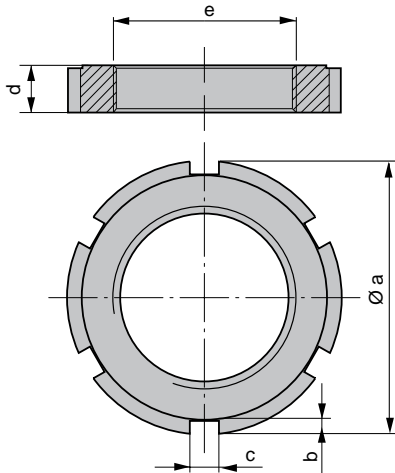

Order No.	Ø a	b	c	d	e
FRM-750	75	3.5	8	13	M50 x 1.5

FTM

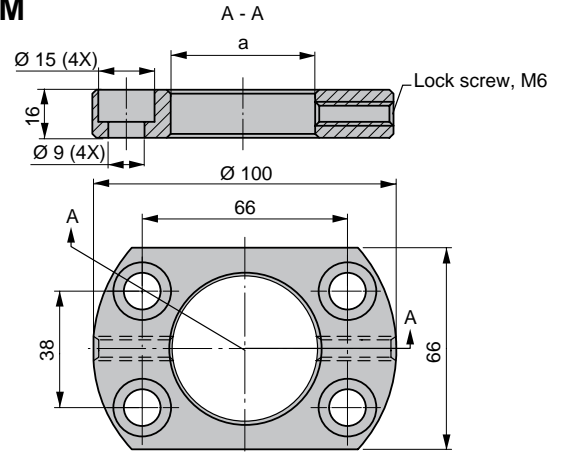

Order No.	a
FTM-750	M50 x 1.5

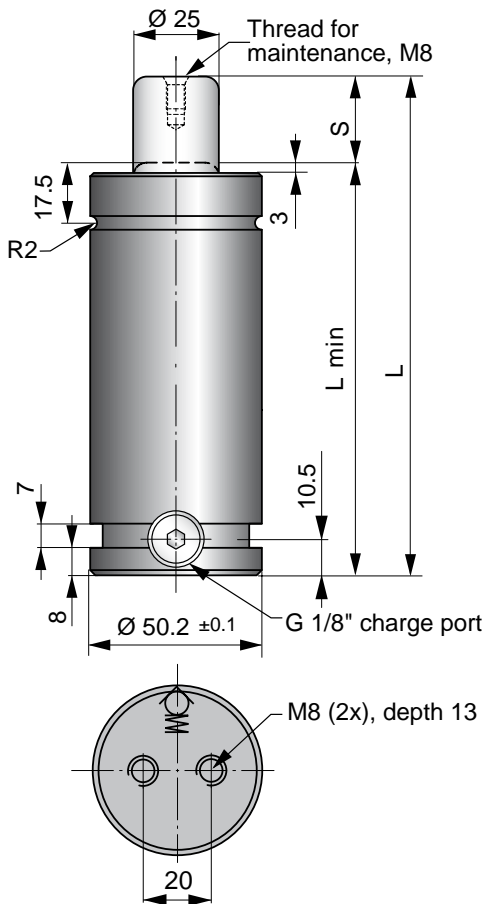

The standard line of gas springs is the TU line. Sizes 250 to 10 000 correspond to the ISO 11901 standard for gas springs.

Sizes 750 to 7500 correspond to FORD's, GM's and Renault's automotive gas spring standards. When ordering a Renault standard gas spring add an R to the Order No. (for example: TUR 1500-xxx).

Note! TUR will be replaced by TUS

5

Being phased out!

TU, TUR and LCF 750 gas springs are also available with double charging ports. When ordering this type, add a D to the Order No.

For example: TUD 750-xxx

Note! TUD, TURD and LCFD 750 gas springs contain no valve and can only be pressurised through connection to a hose system and therefore are always delivered uncharged.

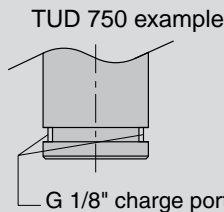

Volvo Part No.	Order No.	S Stroke	Force in N at 150 bar/+20°C		L ±0.25	L min	Gas vol. (l)	Weight (kg)	ISO 111901
			Initial	End force*					
3044184	TU 750-013	12.7	7400	12000	120.4	107.7	0.03	1.33	
9975948	TU 750-025	25		12000	145	120	0.04	1.44	✓
3044185	TU 750-038	38.1		12000	171.2	133.1	0.06	1.57	
9975949	TU 750-050	50		12000	195	145	0.07	1.68	✓
3044186	TU 750-064	63.5		12000	222	158.5	0.09	1.78	
9975950	TU 750-080	80		12000	255	175	0.11	1.94	✓
9975951	TU 750-100	100		12000	295	195	0.14	2.13	✓
9975952	TU 750-125	125		12100	345	220	0.17	2.37	✓
9975953	TU 750-160	160		12100	415	255	0.21	2.70	✓
	TU 750-200	200		12100	495	295	0.26	3.08	
	TU 750-250	250	12100	595	345	0.33	3.55		
	TU 750-300	300	12100	695	395	0.39	4.03		

* = at full stroke

Basic Information

For general information see "About gas springs", 2.1
 Pressure medium Nitrogen
 Max. charging pressure 150 bar
 Min. charging pressure 25 bar
 Operating temperature 0 to +80°C
 Force increase by temperature ±0.3%/°C
 Recommended max strokes/min ~ 15-40 (at 20°C)
 Max piston rod velocity 1.6 m/s

Rod surface Nitrided
 Tube surface Black oxide
 Repair kits

*TU 750 new version 3019817
 Volvo Part No. 3051070
 TU 750 old version 2014068-01

Volvo Part No. 3040923
 *New version is identified by circular rings on the top of tube, guide and rod.

Mounting Possibilities

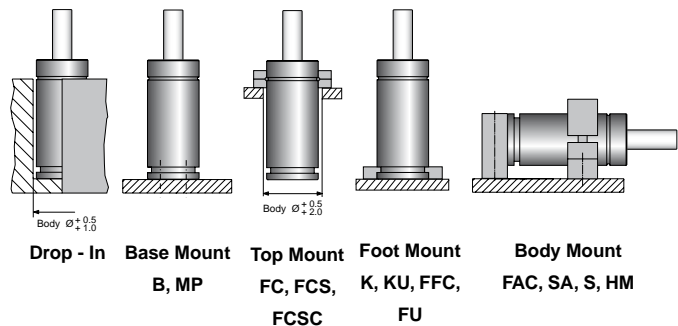

Note! For dimensions on mounting possibilities K-750, KU-750, FU-750, FAC-750, SA-750 and FCSC-750 refer to Chapter 3.

MP

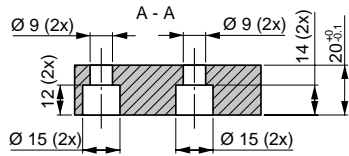

Note! Comes complete with screws to mount gas spring.

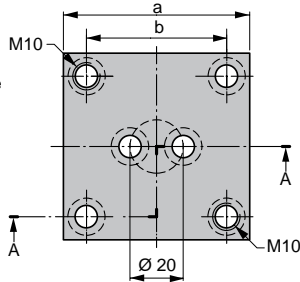

Order No.	a	b
MP-750	75	56.5

FC

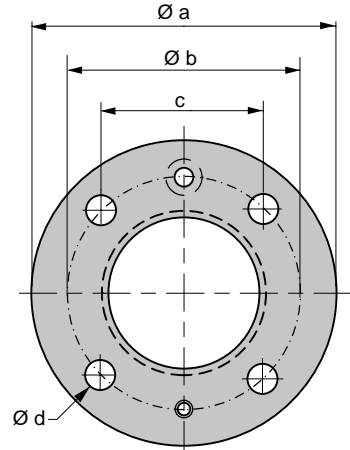
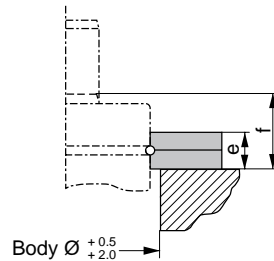

Order No.	Ø a	Ø b	c	Ø d	e	f
FC-750	95	80	56.5	9	13	24

FCS

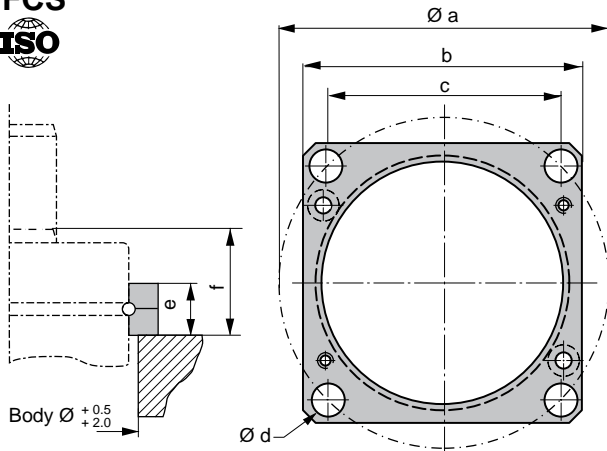

Volvo Part No.	Order No.	Ø a	b	c	Ø d	e	f
3044691	FCS-750	80	70	56.5	9	13	24

FFC

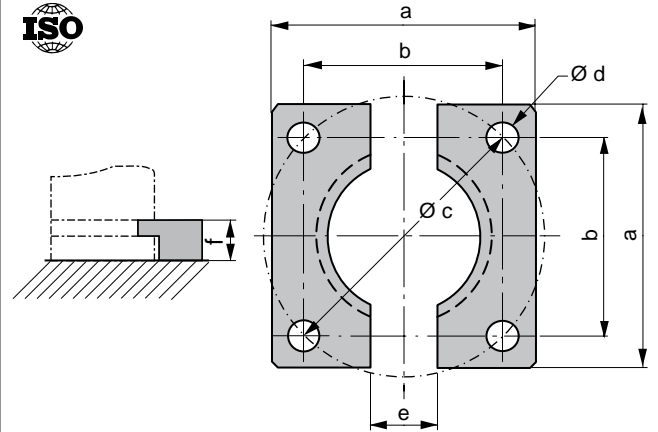

Volvo Part No.	Order No.	a	b	Ø c	Ø d	e	f
3054000	FFC-750	75	56.5	80	9	24	12

S



Note! Support S is designed to be used in combination with flanges mounted in the U or C groove or mount option B.

The mounting screw (M8) should be tightened with torque 25 Nm.

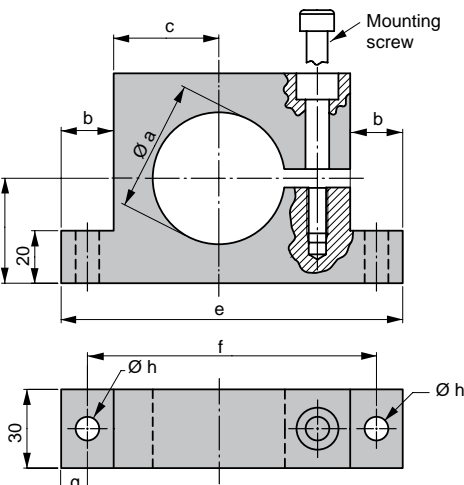

Volvo Part No.	Order No.	Ø a	b	c	d	e	f	g	Ø h
3044221	S-750	50.4	20	40	40	130	110	10	9

Note! For dimensions on mounting possibilities K-750, KU-750, FU-750, FAC-750, SA-750 and FCSC-750, refer to Chapter 3.

The TUS High Speed gas springs are engineered to withstand press stroke speeds to a maximum 2 m/s, which meet the safety demands from the French automotive manufacturer Renault.

These gas springs are available in sizes 750 to 7500 and dimensions correspond to the ISO 11901 standard for gas springs.

TUS gas spring will replace TUR that is being phased out.

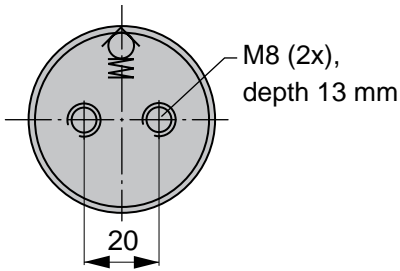
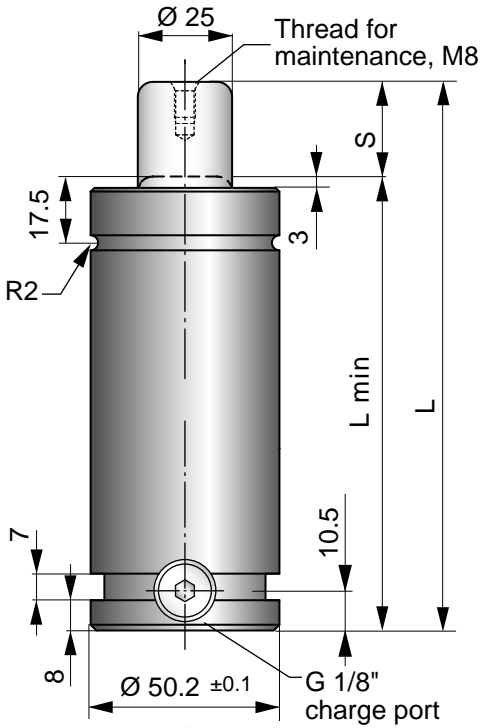

Order No.	S Stroke	Force in N at 150 bar/+20°C		L ±0.25	L min	Gas vol. (l)	Weight (kg)
		Initial	End force*				
TUS 750-025	25	7400	12000	145	120	0.04	1.44
TUS 750-050	50		12000	195	145	0.07	1.68
TUS 750-080	80		12000	255	175	0.11	1.94
TUS 750-100	100		12000	295	195	0.14	2.13
TUS 750-125	125		12100	345	220	0.17	2.37
TUS 750-160	160		12100	415	255	0.21	2.70
TUS 750-200	200		12100	495	295	0.26	3.08
TUS 750-250	250		12100	595	345	0.33	3.55
TUS 750-300	300		12100	695	395	0.39	4.03

* = at full stroke

Basic Information

- For general information see "About gas springs", 2.1
- Pressure medium Nitrogen
- Max. charging pressure 150 bar
- Min. charging pressure..... 25 bar
- Operating temperature 0 to +80°C
- Force increase by temperature ±0.3%/°C
- Recommended max strokes/min ~ 15-40 (at 20°C)
- Max piston rod velocity 2 m/s
- Rod surface..... Nitrided
- Tube surface Black oxide
- Repair kit 3019277

Mounting Possibilities

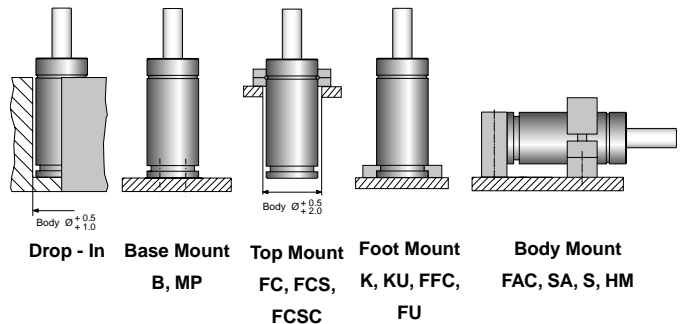

Note! For dimensions on mounting possibilities K-750, KU-750, FU-750, FAC-750, SA-750 and FCSC-750 refer to Chapter 3.

MP
ISO

Note! Comes complete with screws to mount gas spring.

Order No.	a	b
MP-750	75	56.5

FC
ISO

Order No.	Ø a	Ø b	c	Ø d	e	f
FC-750	95	80	56.5	9	13	24

FCS
ISO

Volvo Part No.	Order No.	Ø a	b	c	Ø d	e	f
3044691	FCS-750	80	70	56.5	9	13	24

FFC
ISO

Volvo Part No.	Order No.	a	b	Ø c	Ø d	e	f
3054000	FFC-750	75	56.5	80	9	24	12

S
ISO

Note! Support S is designed to be used in combination with flanges mounted in the U or C groove or mount option B.

The mounting screw (M8) should be tightened with torque 25 Nm.

Order No.	Ø a	b	c	d	e	f	g	Ø h
S-750	50.4	20	40	40	130	110	10	9

Note! For dimensions on mounting possibilities K-750, KU-750, FU-750, FAC-750, SA-750 and FCSC-750, refer to Chapter 3.

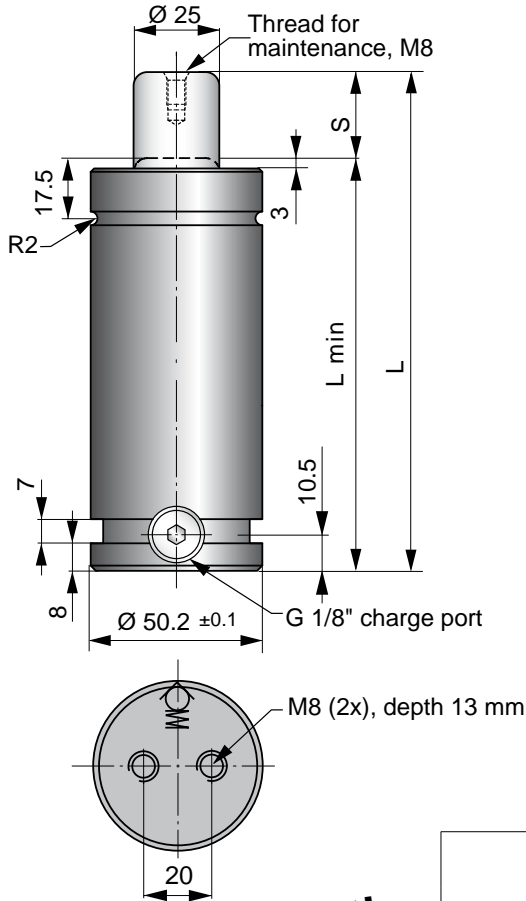

Low Contact Force (LCF) gas springs are designed to reduce excessive shock loads, high noise levels and extreme pad bounce, all factors that lead to high press maintenance costs and noise pollution. For more information see "About Gas Springs" 2.1/2.

5

Force vs Stroke for LCF 750 Springs

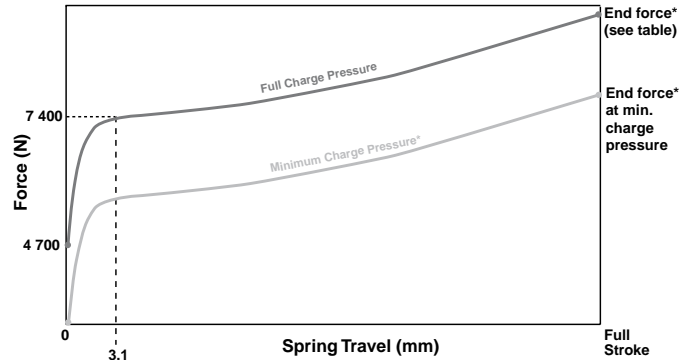

Being phased out!

TU, TUR and LCF 750 gas springs are also available with double charging ports. When ordering this type, add a D to the Order No.

For example: LCDF 750-xxx

LCDF 750 example

Note! TUD, TURD and LCDF 750 gas springs contain no valve and can only be pressurised through connection to a hose system and therefore are always delivered uncharged.

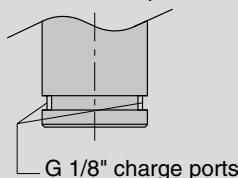

Volvo Part No.	Order No.	S Stroke	Force in N at 150 bar/+20°C		L ±0.25	L min	Gas vol. (l)	Weight (kg)
			Initial	End force*				
	LCF 750-013	12.7	7400	12000	120.4	107.7	0.03	1.30
	LCF 750-025	25		12000	145	120	0.04	1.45
	LCF 750-038	38.1		12000	171.2	133.1	0.06	1.50
	LCF 750-050	50		12000	195	145	0.07	1.70
	LCF 750-064	63.5		12000	222	158.5	0.09	1.75
	LCF 750-080	80		12000	255	175	0.11	1.95
	LCF 750-100	100		12000	295	195	0.14	2.15
	LCF 750-125	125		12100	345	220	0.17	2.40
	LCF 750-160	160		12100	415	255	0.21	2.70
	LCF 750-200	200		12100	495	295	0.26	3.10
	LCF 750-250	250		12100	595	345	0.33	3.60
	LCF 750-300	300		12100	695	395	0.39	4.10

* = at full stroke

Basic Information

- For general information see "About gas springs", 2.1
- Pressure medium Nitrogen
- Max. charging pressure 150 bar
- Min. charging pressure..... 70 bar
- Operating temperature 0 to +80°C
- Force increase by temperature ±0.3%/°C
- Recommended max strokes/min ~ 15-40 (at 20°C)
- Max piston rod velocity 1.6 m/s

- Rod surface..... Nitrided
- Tube surface Black oxide
- Repair kits

*LCF 750 new version..... 3019377

*New version is identified by circular rings on the top of tube, guide and rod.

Mounting Possibilities

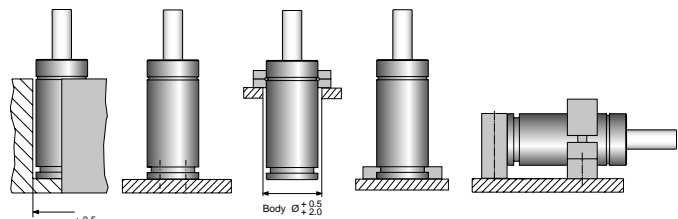

- Drop - In**
- Base Mount**
B, MP
- Top Mount**
FC, FCS, FCSC
- Foot Mount**
K, KU, FFC, FU
- Body Mount**
FAC, SA, S, HM

Note! For dimensions on mounting possibilities K-750, KU-750, FU-750, FAC-750, SA-750 and FCSC-750 refer to Chapter 3.

MP
ISO

Note! Comes complete with screws to mount gas spring.

Order No.	a	b
MP-750	75	56.5

FC
ISO

Order No.	Ø a	Ø b	c	Ø d	e	f
FC-750	95	80	56.5	9	13	24

FCS
ISO

Volvo Part No.	Order No.	Ø a	b	c	Ø d	e	f
3044691	FCS-750	80	70	56.5	9	13	24

FFC
ISO

Volvo Part No.	Order No.	a	b	Ø c	Ø d	e	f
3054000	FFC-750	75	56.5	80	9	24	12

S
ISO

Note! Support S is designed to be used in combination with flanges mounted in the U or C groove or mount option B.

The mounting screw (M8) should be tightened with torque 25 Nm.

Volvo Part No.	Order No.	Ø a	b	c	d	e	f	g	Ø h
3044221	S-750	50.4	20	40	40	130	110	10	9

Note! For dimensions on mounting possibilities K-750, KU-750, FU-750, FAC-750, SA-750 and FCSC-750, refer to Chapter 3.

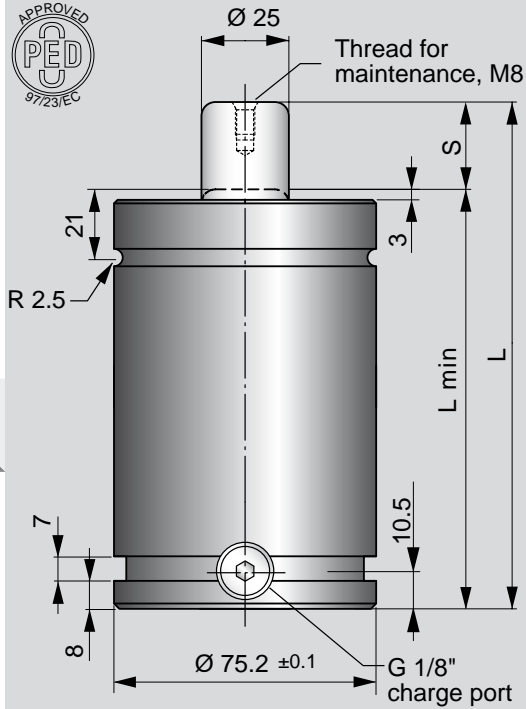

TB springs have a larger gas volume than our standard TU series. This reduces the pressure increase as the piston rod is stroked. It also increases the service life of the spring.

TB springs are recommended for applications where a low force increase is desirable. TB springs are also a good choice for higher cycle rates and high volume production.

Note! When ordering mounts for TB 750 springs, a mount of a larger size than the spring must be used.

5

Being phased out!

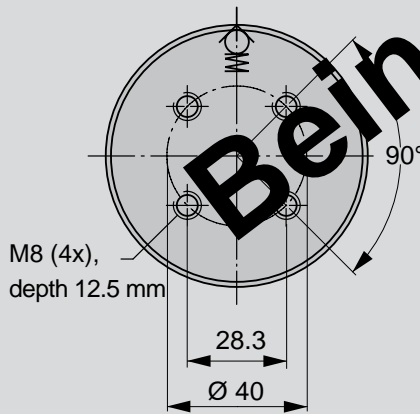

Volvo Part No.	Order No.	S Stroke	Force in N at 150 bar/+20°C		L ±0.25	L min	Gas vol. (l)	Weight (kg)
			Initial	End force*				
3044139	TB 750-013	12.7	7400	9500	120.4	107.7	0.06	3.05
3044140	TB 750-025	25		9000	145	120	0.10	3.15
3044141	TB 750-038	38.1		9000	171.2	133.1	0.14	3.35
3044142	TB 750-050	50		8900	195	145	0.17	3.50
3044143	TB 750-064	63.5		8800	222	158.5	0.22	3.75
3044144	TB 750-080	80		8800	255	175	0.27	3.95
3044145	TB 750-100	100		8800	295	195	0.33	4.25
3044146	TB 750-125	125		8800	345	220	0.41	4.65
3044147	TB 750-160	160		8800	415	255	0.52	5.15
	TB 750-200	200		8800	495	295	0.64	5.65
	TB 750-250	250	8800	595	345	0.80	6.45	
	TB 750-300	300	8800	695	395	0.95	7.25	

* = at full stroke

Basic Information

- For general information see "About gas springs", 2.1
- Pressure medium Nitrogen
- Max. charging pressure 150 bar
- Min. charging pressure 25 bar
- Operating temperature 0 to +80°C
- Force increase by temperature ±0.3%/°C
- Recommended max strokes/min ~ 40-80 (at 20°C)
- Max piston rod velocity 1.6 m/s

- Rod surface..... Nitrided
- Tube surface Black oxide
- Repair kit..... 2014068-05
- Repair kit Volvo Part No. 3044228

Mounting Possibilities

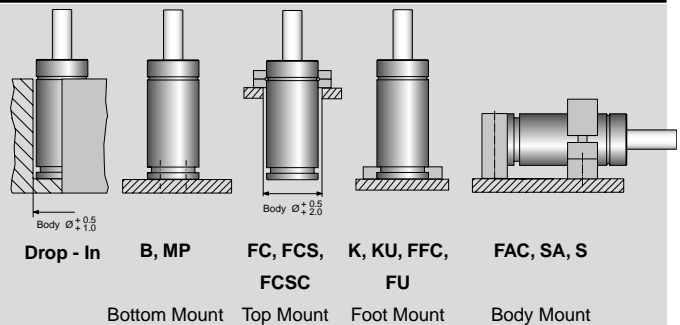

Note! For dimensions on mounting possibilities K-1500, KU-1500, FU-1500, FAC-1500, SA-1500 and FCSC-1500 refer to Chapter 3.

MP
ISO

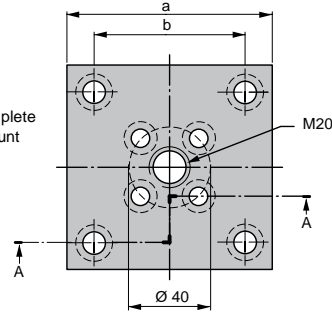
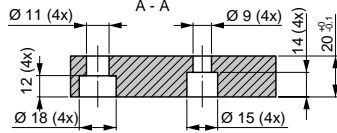

Note! Comes complete with screws to mount gas spring.

Order No.	a	b
MP-1500	100	73.5

FC
ISO

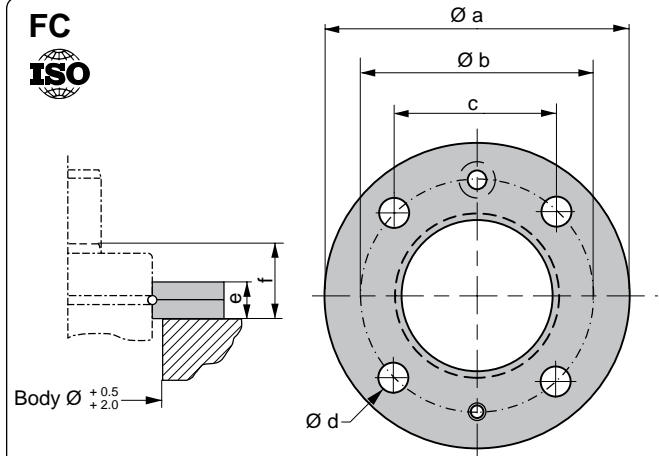

Order No.	Ø a	Ø b	c	Ø d	e	f
FC-1500	122	104	73.5	11	16	29

FCS
ISO

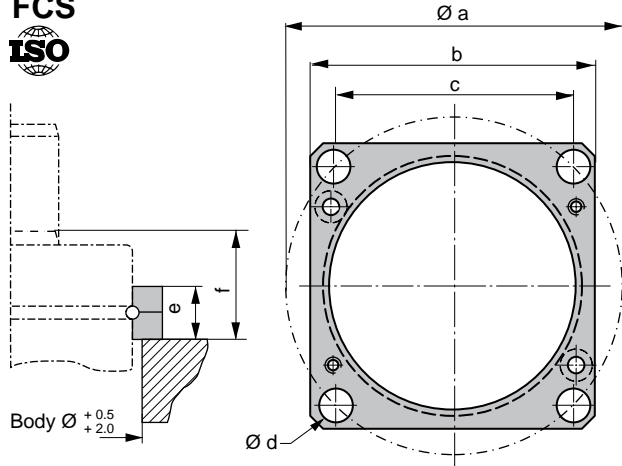

Volvo Part No.	Order No.	Ø a	b	c	Ø d	e	f
3044009	FCS-1500	104	90	73.5	11	16	29

FFC
ISO

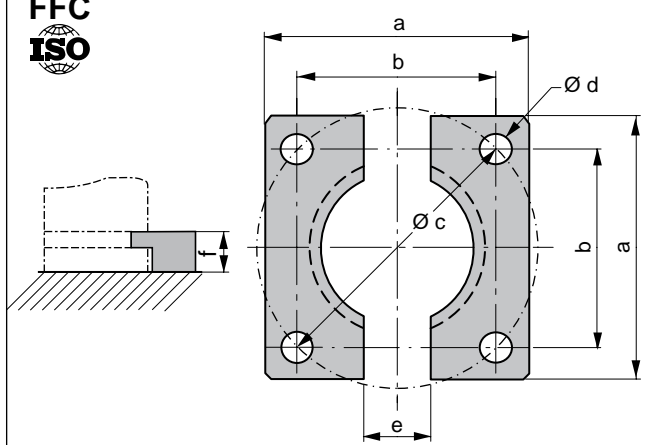

Volvo Part No.	Order No.	a	b	Ø c	Ø d	e	f
3054001	FFC-1500	100	73.5	104	11	24	12

S
ISO

Note! Support S is designed to be used in combination with flanges mounted in the U or C groove or attachment B.

The mounting screw (M10) should be tightened with torque 52 Nm.

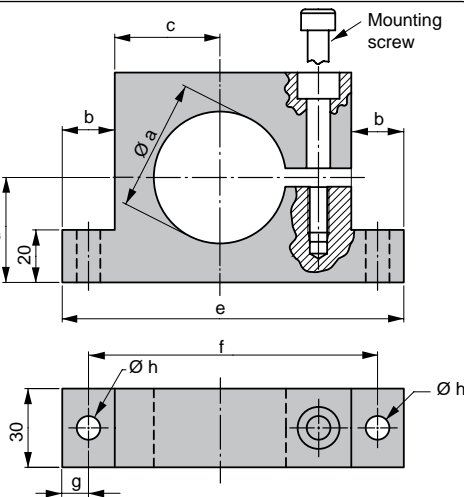

Volvo Part No.	Order No.	Ø a	b	c	d	e	f	g	Ø h
3044222	S-1500	75.4	22.5	52.5	52.5	160	137	11.5	11

Note! For dimensions on mounting possibilities K-1500, KU-1500, FU-1500, FAC-1500, SA-1500 and FCSC-1500, refer to Chapter 3.

SL 750

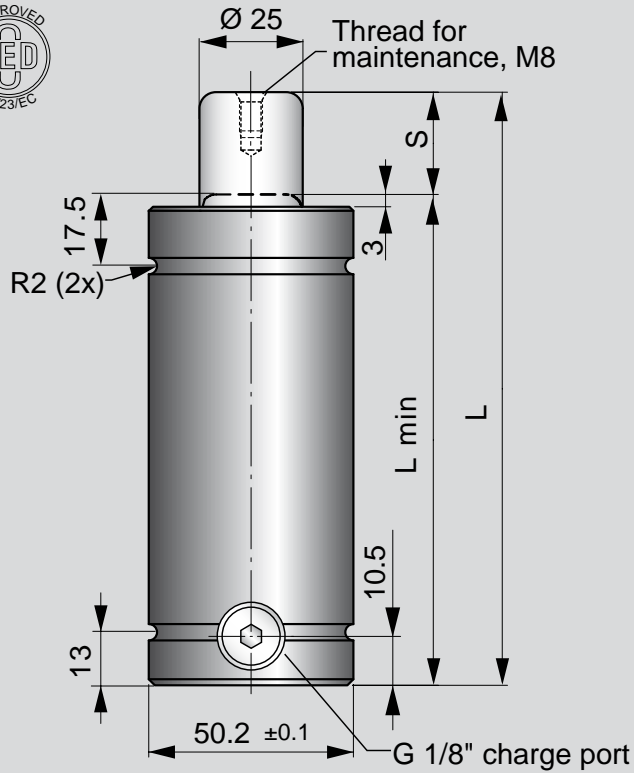

This 750 spring has "inch-based" total length and stroke length.

The SL 750 has a total length of 95 mm +(2 x stroke), the same length as for the TU 750.

5

Being phased out!

M10 (2x), depth 12.5 mm



Order No.	S Stroke	Force in Nat 150 bar/+20°C		L ±0.25	L min	Gas vol. (l)	Weight (kg)
		Initial	End force*				
SL 750-013	12.7	7400	12000	120.4	107.7	0.03	1.30
SL 750-025	25.4		12000	145.8	120.4	0.04	1.40
SL 750-038	38.1		12000	171.2	133.1	0.06	1.60
SL 750-051	50.8		12000	196.6	145.8	0.07	1.70
SL 750-064	63.5		12000	222	158.5	0.09	1.80
SL 750-076	76.2		12000	247.4	171.2	0.11	1.90
SL 750-089	88.9		12000	272.8	183.9	0.12	2.10
SL 750-102	101.6		12000	298.2	196.6	0.14	2.20
SL 750-114	114.3		12000	323.6	209.3	0.15	2.30
SL 750-127	127		12000	349	222	0.17	2.40

Basic Information

For general information see "About gas springs", 2.1
 Pressure medium Nitrogen
 Max. charging pressure 150 bar
 Min. charging pressure 25 bar
 Operating temperature 0 to +80°C
 Force increase by temperature ±0.3%/°C
 Recommended max strokes/min ~ 15-40 (at 20°C)
 Max piston rod velocity 1.6 m/s

Rod surface Nitrided
 Tube surface Yellow chromed
 Repair kits
 *SL 750 new version 3019377
 SL 750 old version 2014068-01
 *New version is identified by circular rings on the top of tube, guide and rod.

Mounting Possibilities

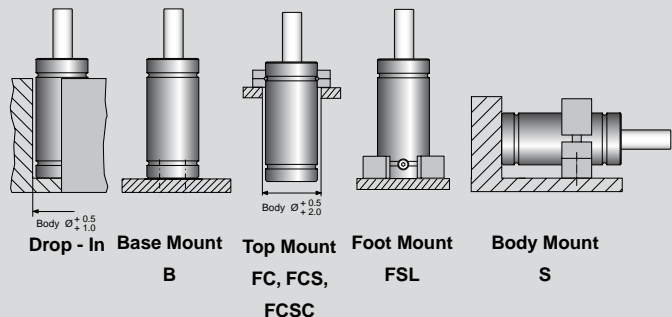

Note! For dimensions on mounting possibility FCSC-750 refer to Chapter 3.

FC
ISO

Body $\varnothing \begin{matrix} +0.5 \\ +2.0 \end{matrix}$

Order No.	Ø a	Ø b	c	Ø d	e	f
FC-750	95	80	56.5	9	13	24

FCS
ISO

Body $\varnothing \begin{matrix} +0.5 \\ +2.0 \end{matrix}$

Order No.	Ø a	b	c	Ø d	e	f
FCS-750	80	70	56.5	9	13	24

FSL

Order No.	a	b	Ø c	d	Ø e	Ø f	g	h	i	j
FSL-750	76.2	53.9	76.2	35	16	11	11	25	25.9	26

S
ISO

Note! Support S is designed to be used in combination with flanges mounted in the C groove or mounting option B.

The mounting screw (M8) should be tightened with torque 25 Nm.

Order No.	Ø a	b	c	d	e	f	g	Ø h
S-750	50.4	20	40	40	130	110	10	9

Note! For dimensions on mounting possibility FCSC-750 refer to Chapter 3.

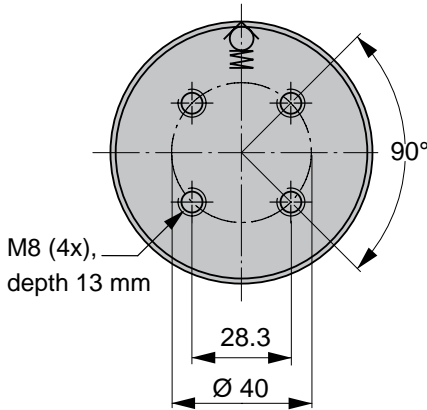
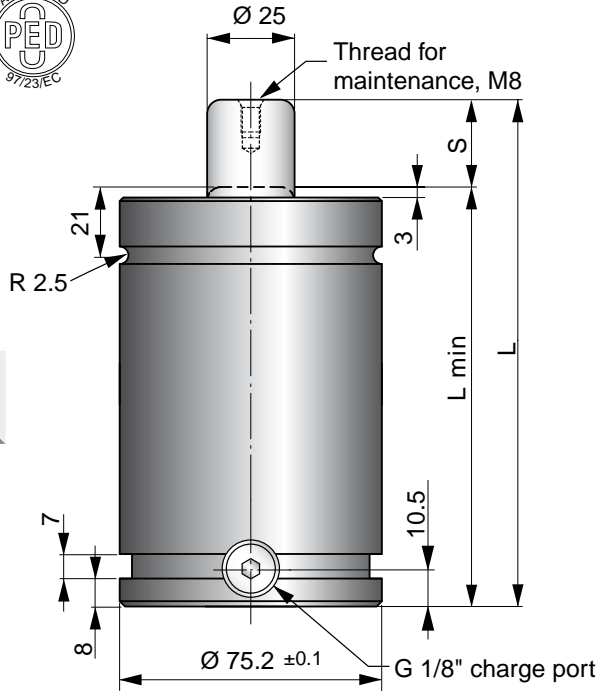

Speed Control™ – SPC gas springs have been engineered to eliminate blank holder bounce; commonly associated with increased return stroke speeds from link drive presses.

SPC gas springs have inbuilt return stroke **speed dampening**, which decelerates the last 30 mm of piston rod stroke to 0.4 m/s, helping to bring the blank holder to a smooth stop.

Speed Control™ – SPC features:

- Eliminate blank holder bounce
- Increase productivity by increasing part transfer efficiency
- Easily retrofitted to existing dies
- Stroke lengths 125 to 300 mm
- Linkable using hose-system

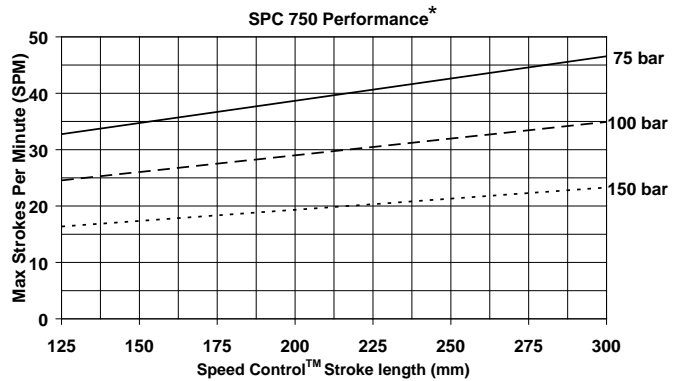

*At ambient room temperatures with free air flow

Order No.	S Stroke	Force in N at 150 bar/+20°C		L ±0.25	L min	Gas vol. (l)	Weight (kg)
		Initial	End force*				
SPC 750-125	125	7400	8700	360	235	0.44	6.10
SPC 750-160	160			430	270	0.55	6.60
SPC 750-200	200			510	310	0.67	7.15
SPC 750-250	250			610	360	0.83	7.85
SPC 750-300	300			710	410	0.98	8.60

*at full stroke

Basic Information

For general information see "About gas springs", 2.1
 Pressure mediumNitrogen
 Max. charging pressure150 bar (at 20°C)
 Min. charging pressure25 bar (at 20°C)
 Operating temperature0 to +80°C
 Force increase by temperature.....±0.3%/°C
 Recommended max strokes/minSee chart
 Dampening length≈ 30 mm
 Dampening speed0.4 m/s

Rod surfaceNitrided
 Tube surfaceBlack oxide
 Repair kit3021490

Mounting Possibilities

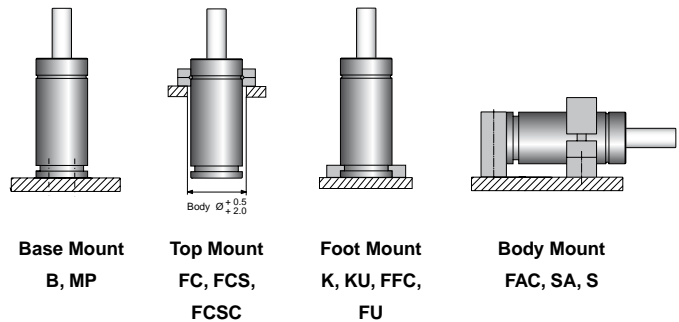

Note! For dimensions on mounting possibilities K-1500, KU-1500, FU-1500, FAC-1500, SA-1500 and FCSC-1500 refer to Chapter 3.

MP
ISO

Note! Comes complete with screws to mount gas spring.

Order No.	a	b
MP-1500	100	73.5

FC
ISO

Order No.	Ø a	Ø b	c	Ø d	e	f
FC-1500	122	104	73.5	11	16	29

FCS
ISO

Order No.	Ø a	b	c	Ø d	e	f
FCS-1500	104	90	73.5	11	16	29

FFC
ISO

Order No.	a	b	Ø c	Ø d	e	f
FFC-1500	100	73.5	104	11	24	12

S
ISO

Note! Support S is designed to be used in combination with flanges mounted in the U or C groove or attachment B.

The mounting screw (M10) should be tightened with torque 52 Nm.







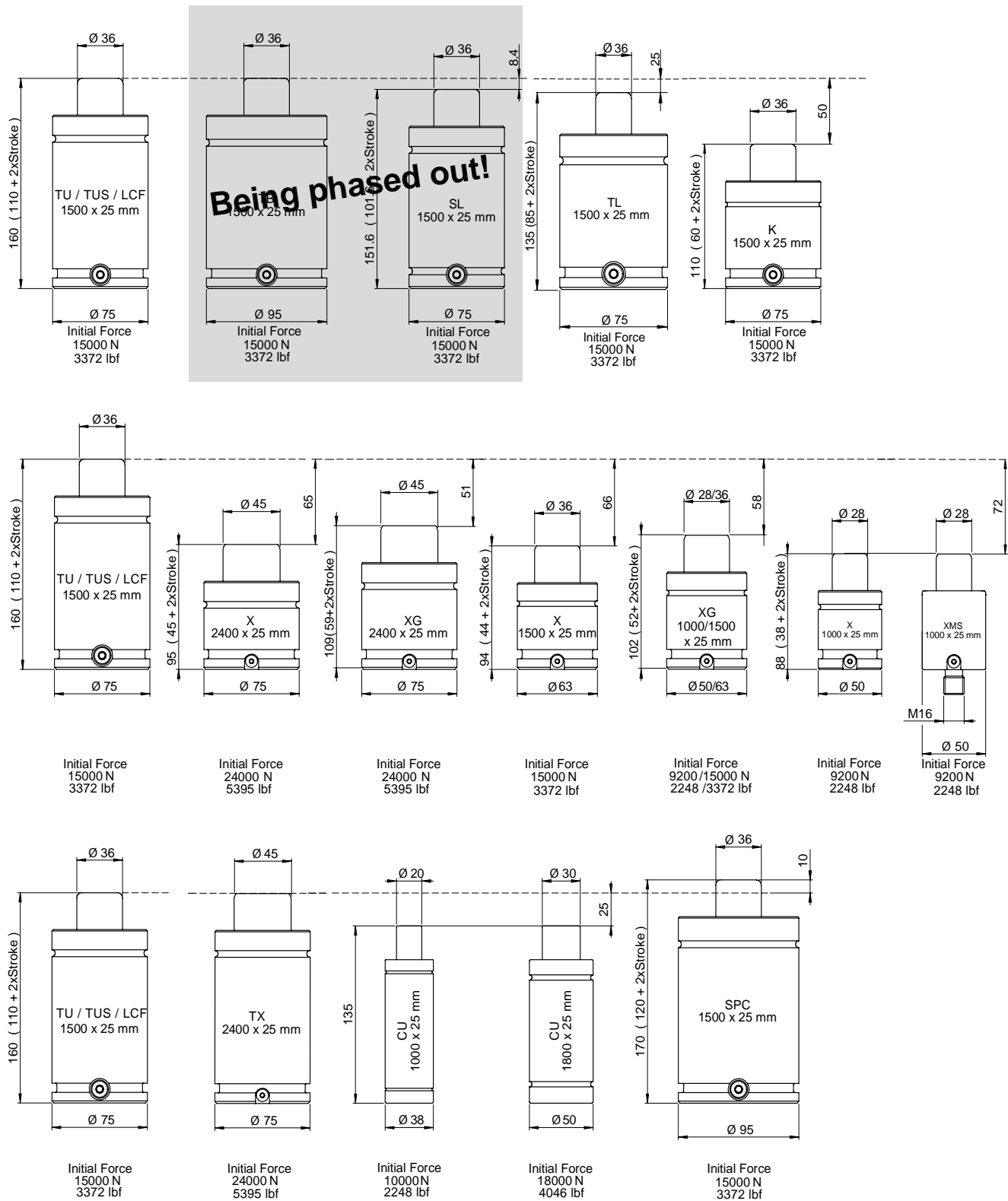









Order No.	Ø a	b	c	d	e	f	g	Ø h
S-1500	75.4	22.5	52.5	52.5	160	137	11.5	11

Note! For dimensions on mounting possibilities K-1500, KU-1500, FU-1500, FAC-1500, SA-1500 and FCSC-1500 refer to Chapter 3.

Overview - $10000 \leq F_{INIT} < 25000$



10000 ≤ F_{INIT} < 25000

CU 1000 - 1800		Page 2.6/2
X 1000 and XMS 1000		Page 2.6/4
XG 1000		Page 2.6/6
TX 1000		Page 2.6/8
X 1500		Page 2.6/10
XG 1500		Page 2.6/12
X 2400		Page 2.6/14
XG 2400		Page 2.6/16
TX 2400		Page 2.6/18
TL 1500		Page 2.6/20
K 1500		Page 2.6/22
TU 1500	 	Page 2.6/24
TUS 1500		Page 2.6/26
LCF 1500		Page 2.6/28
TB 1500 and SL 1500	 Being phased out!	Page 2.6/30/Page 2.6/32
SPC 1500		Page 2.6/34

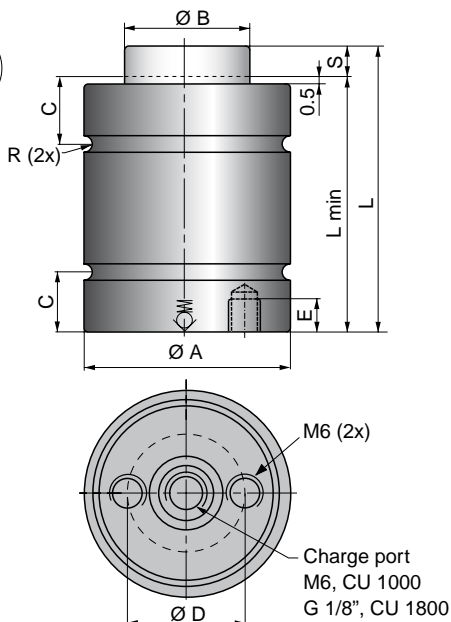

The CU gas spring is a very compact Bore Sealed gas spring, that gives a high force in a limited space. The max. frequency for the spring is 100 strokes/minute.

Springs with stroke lengths over 25 mm should always be attached to the tool, using a flange or the tapped holes in the bottom of the spring. We also recommend shorter stroke springs to be fastened for optimal service-life.

As an option, the CU springs can be delivered with a Side-Port plate (SP) for applications where a side-port is needed (i.e. for use in hose systems).

6

Volvo Part No.	Order No.	S Stroke	Force in N at 150 bar/+20°C		L ±0.25	L min	Ø A ±0.1	Ø B	C	Ø D	E	R	Gas vol. (l)	Weight (kg)
			Initial	End force**										
3044655	CU 1000-006	6		16000	61	55							0.014	0.33
	CU 1000-010	10		16000	78	68							0.024	0.38
3044656	CU 1000-016	16		16000	100	84							0.036	0.44
3044657	CU 1000-025	25	10600	16000	135	110	37.9	20	10.5	17	6.5	1	0.056	0.54
3054639	CU 1000-032	32*		16000	167	135							0.074	0.65
3054640	CU 1000-040	40*		16000	195	155							0.092	0.73
3054641	CU 1000-050	50*		16000	230	180							0.110	0.83
3044658	CU 1800-006	6		25000	66	60							0.030	0.60
	CU 1800-010	10		26000	80	70							0.044	0.66
3044659	CU 1800-016	16		26000	106	90							0.072	0.79
3044660	CU 1800-025	25	18000	27000	135	110	50.2	30	14.5	26	6.5	2	0.100	1.93
3054642	CU 1800-032	32*		27000	162	130							0.126	1.06
3054643	CU 1800-040	40*		28000	190	150							0.150	1.19
3054644	CU 1800-050	50*		29000	220	170							0.179	1.32

* = Should always be attached to the tool using the tapped holes in the bottom or a flange

** = at full stroke

Basic Information

- For general information see "About gas springs", 2.1
- Pressure medium..... Nitrogen
- Max. charging pressure..... 150 bar (at 20°C)
- Min. charging pressure..... 25 bar (at 20°C)
- Operating temperature 0 to +80°C
- Force increase by temperature ±0.3%/°C
- Recommended max strokes/min ~100 (at 20° C)
- Max piston rod velocity 0.5 m/s
- Rod surface Nitrided
- Tube surface Nitrided
- Repair kit CU 1000 2014493
- Repair kit Volvo Part No. 3044673
- Repair kit CU 1800 2014493
- Repair kit Volvo Part No. 3044674

Mounting Possibilities

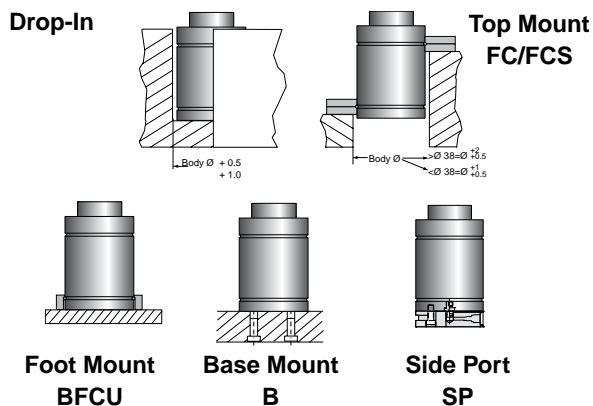

FC

For model	Order No.	Ø a	Ø b	c	Ø d	e	f
CU 1000	FC-250	68	56.5	40	7	9	15
CU 1800	FC-750	95	80	56.5	9	13	21

FCS

Volvo Par No.	For model	Order No.	Ø a	b	c	Ø d	e	f
3044689	CU 1000	FCS-250	56.5	52	40	7	9	15
3044691	CU 1800	FCS-750	80	70	56.5	9	13	21

BFCU

For model	Order No.	a	b	Ø c	d
CU 1000	BFCU-1000	52	40	7	14.5
CU 1800	BFCU-1800	70	56.5	9	19.5

SP 1000

Note! SP-1000 has no valve and can only be pressurised through a hose system and is therefore always delivered uncharged.

It is also possible to order Side Port kit for attachment to old springs.

For model	Order No.	For U-groove mounts on SP
CU 1000	SP-1000	Refer to TU 250

SP 1800

Note! SP-1800 has no valve and can only be pressurised through a hose system and is therefore always delivered uncharged.

It is also possible to order Side Port kit for attachment to old springs.

For model	Order No.	For U-groove mounts on SP
CU 1800	SP-1800	Refer to TU 750

We reserve the right to add, delete or modify components without notification.
 All dimensions are stated in mm.
 All dimensions are nominal unless tolerance is stated.

X 1000 and XMS 1000

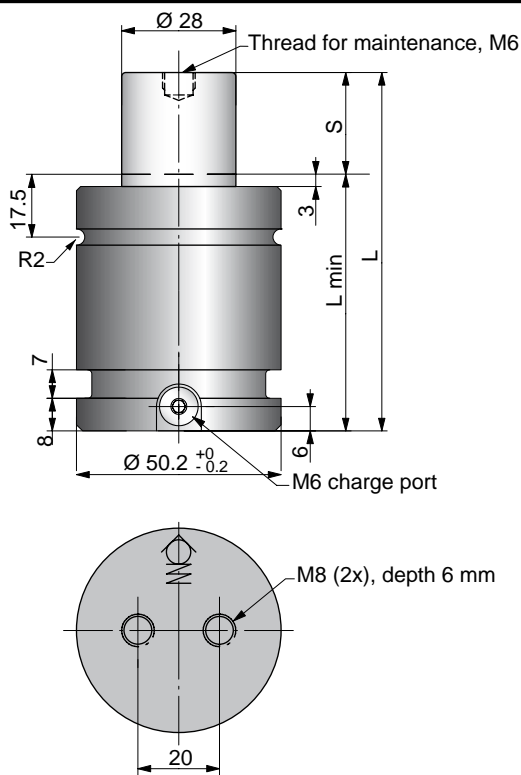

The Power Line series are our shortest and most powerful Piston Rod Sealed gas springs, giving you a great deal of force in a very small amount of space.

These gas springs are available with forces from 1700 N up to 200000 N and stroke lengths between 7 and 125 mm.

There is a side port for gas charging that can also be used to connect to a hose system.

An upper C-groove, lower U-groove together with two M8 threaded holes allow various mounting possibilities using our standard mounts.

The X 1000 model is also available equipped with an M16 threaded tap for mounting. When ordering this version **XMS 1000-xxx** must be stated on the order

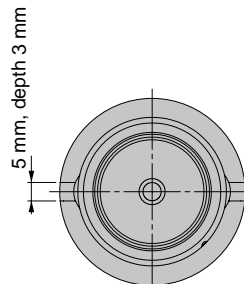

Volvo Part No. X / XMS	Order No.	S Stroke	Force in N at 150 bar/+20°C		L ±0.25	L min	Gas vol. (l)	Weight (kg)
			Initial	End force*				
3050755	X/XMS 1000-013	13	9200	13800	64	51	0.03	0.50
3050756	X/XMS 1000-016	16		13800	70	54	0.04	0.52
3050757	X/XMS 1000-019	19		14000	76	57	0.04	0.54
3050758	3054732 X/XMS 1000-025	25		14200	88	63	0.05	0.59
3050759	X/XMS 1000-032	32		14300	102	70	0.06	0.64
3050760	3054733 X/XMS 1000-038	38		14500	114	76	0.07	0.70
3050761	3054734 X/XMS 1000-050	50		14600	138	88	0.09	0.79
3050762	3054735 X/XMS 1000-063	63		14700	164	101	0.11	0.89
3050763	X/XMS 1000-075	75		14700	188	113	0.13	0.99
3050764	3054736 X/XMS 1000-080	80		14800	198	118	0.14	1.03
3050765	3054737 X/XMS 1000-100	100		14800	238	138	0.17	1.19
3050766	3054738 X/XMS 1000-125	125		14800	288	163	0.21	1.39

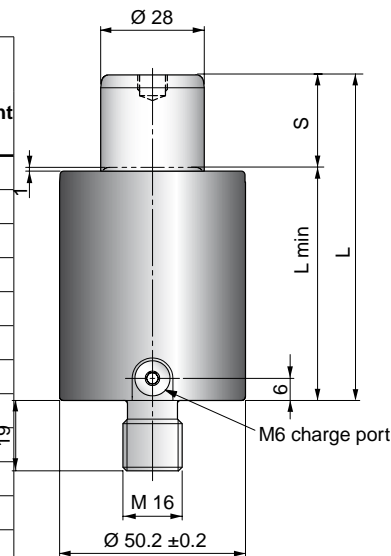

* = at full stroke

Basic Information

For general information see "About gas springs", 2.1
 Pressure medium Nitrogen
 Max. charging pressure 150 bar (at 20°C)
 Min. charging pressure 25 bar (at 20°C)
 Operating temperature 0 to +80°C
 Force increase by temperature ±0.3%/°C
 Recommended max strokes/min ... ~ 50 to 100 (at 20°C)
 Max piston rod velocity 1.6 m/s

Rod surface Nitrided
 Tube surface Black oxide
 Repair kit 3018847
 Repair kit Volvo Part No 3050728

Mounting Possibilities

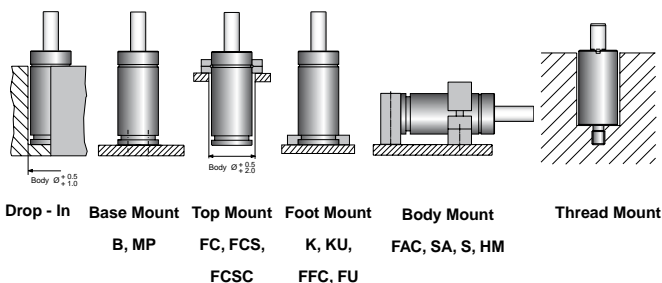

Note! For dimensions on mounting possibilities K-750, KU-750, FU-750, FAC-750, SA-750, HM-750 and FCSC-750 refer to Chapter 3.

MP
ISO

Note! Comes complete with screws to mount gas spring.

Order No.	a	b
MP-750	75	56.5

FC
ISO

Order No.	Ø a	Ø b	c	Ø d	e	f
FC-750	95	80	56.5	9	13	24

FCS
ISO

Volvo Part No.	Order No.	Ø a	b	c	Ø d	e	f
3044009	FCS-1500	104	90	73.5	11	16	29

FFC
ISO

Volvo Part No.	Order No.	a	b	Ø c	Ø d	e	f
3054001	FFC-1500	100	73.5	104	11	24	12

S
ISO

Note! Support S is designed to be used in combination with flanges mounted in the U or C groove or attachment B.

The mounting screw (M8) should be tightened with torque 25 Nm.

Volvo Part No.	Order No.	Ø a	b	c	d	e	f	g	Ø h
3044222	S-1500	75.4	22.5	52.5	52.5	160	137	11.5	11

Note! For dimensions on mounting possibilities K-750, KU-750, FU-750, FAC-750, SA-750, HM-750 and FCSC-750 refer to Chapter 3.

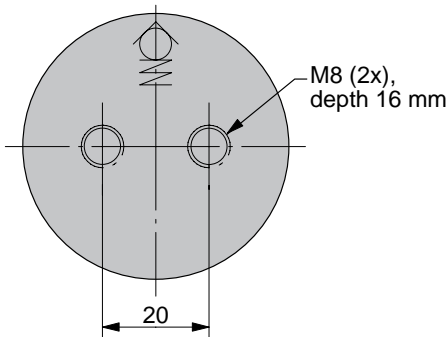
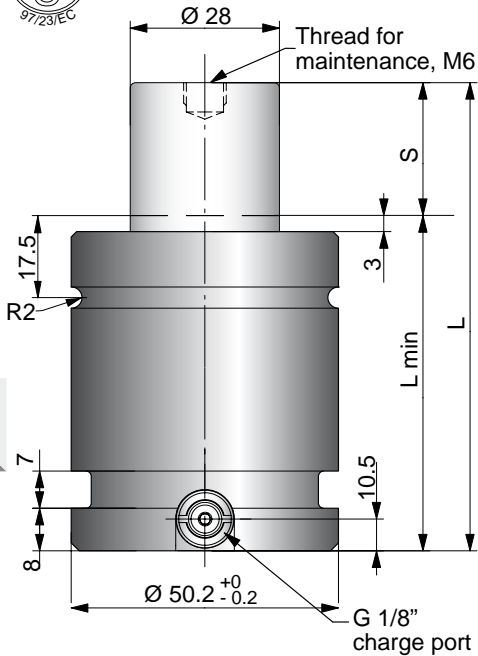

The Power Line series are our shortest and most powerful Piston Rod Sealed gas springs, giving you a great deal of force in a very small amount of space.

These gas springs are available with forces from 3500 N up to 66000 N and stroke lengths between 13 and 125 mm.

There is a side port for gas charging that can also be used to connect to a hose system.

An upper C-groove, lower U-groove together with two M8 threaded holes allow various mounting possibilities using our standard mounts.

Order No.	S Stroke	Force in N at 150 bar/+20°C		L ±0.25	L min	Gas vol. (l)	Weight (kg)
		Initial	End force*				
XG 1000-013	13	9200	13800	78	65	0.03	0.70
XG 1000-016	16		13800	84	68	0.04	0.72
XG 1000-019	19		14000	90	71	0.04	0.74
XG 1000-025	25		14200	102	77	0.05	0.79
XG 1000-032	32		14300	116	84	0.06	0.84
XG 1000-038	38		14500	128	90	0.07	0.89
XG 1000-050	50		14600	152	102	0.09	0.98
XG 1000-063	63		14700	178	115	0.11	1.09
XG 1000-075	75		14700	202	127	0.13	1.18
XG 1000-080	80		14800	212	132	0.14	1.22
XG 1000-100	100		14800	252	152	0.17	1.41
XG 1000-125	125		14800	302	177	0.21	1.60

* = at full stroke

Basic Information

- For general information see "About gas springs", 2.1
- Pressure medium Nitrogen
- Max. charging pressure 150 bar (at 20°C)
- Min. charging pressure 25 bar (at 20°C)
- Operating temperature 0 to +80°C
- Force increase by temperature ±0.3%/°C
- Recommended max strokes/min ... ~ 50 to 100 (at 20°C)
- Max piston rod velocity 1.6 m/s
- Rod surface Nitrided
- Tube surface Black oxide
- Repair kit 3018847

Mounting Possibilities

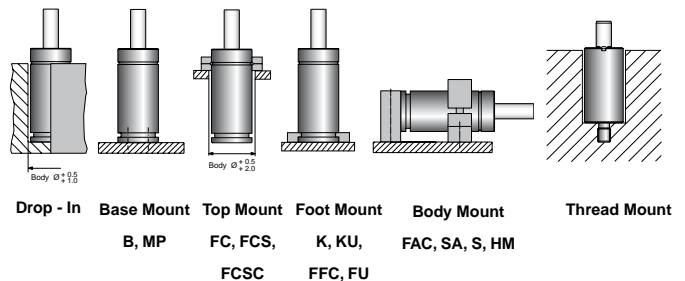

Note! For dimensions on mounting possibilities K, KU, FU, FAC, SA and HM refer to chapter 3.

MP
ISO

Note! Comes complete with screws to mount gas spring.

Order No.	a	b
MP-750	75	56.5

FC
ISO

Order No.	Ø a	Ø b	c	Ø d	e	f
FC-750	95	80	56.5	9	13	22

FCS
ISO

Order No.	Ø a	b	c	Ø d	e	f
FCS-750	80	70	56.5	9	13	22

FFC
ISO

Order No.	a	b	Ø c	Ø d	e	f
FFC-750	75	56.5	80	9	24	12

S
ISO

Note! Support S is designed to be used in combination with flanges mounted in the U or C groove or attachment B.

The mounting screw (M8) should be tightened with torque 25 Nm.

Order No.	Ø a	b	c	d	e	f	g	Ø h
S-750	50.4	20	40	40	130	110	10	9

Note! For dimensions on mounting possibilities K, KU, FU, FAC, SA and HM refer to chapter 3.

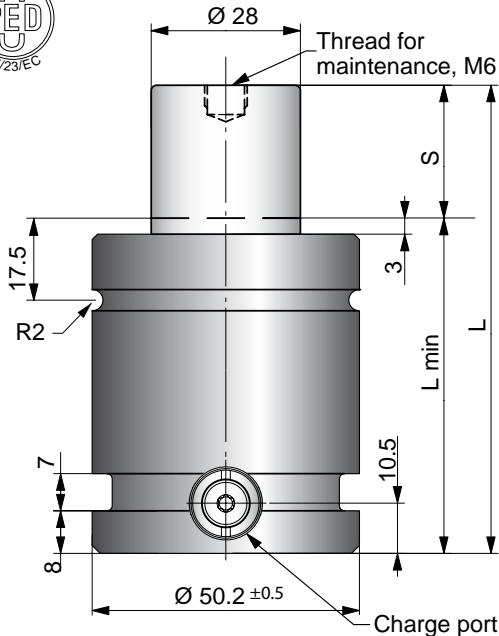

The Power Line - Heavy Duty series is a crossover between the standard TU series and Power Line X series.

These gas springs are available with forces from 9200 N up to 95000 N and stroke lengths between 13 and 300 mm.

There is an optional bottom port for hose/base plate connection.

An upper C-groove, lower U-groove and bottom threaded holes allow various mounting possibilities using our standard mounts.

6

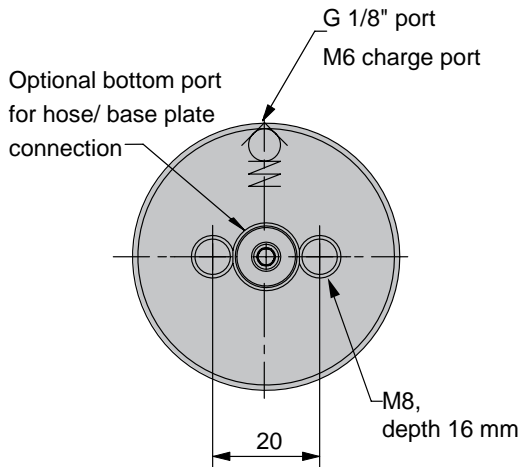

Volvo Part No.	Order No.	S Stroke	Force in N at 150 bar/+20°C		L ±0.25	L min	Gas vol. (l)	Weight (kg)
			Initial	End force*				
	TX 1000-013	13	9200	11200	121	108	0.06	1.17
3054682	TX 1000-025	25		12100	145	120	0.07	1.27
3054683	TX 1000-038	38		12800	171	133	0.09	1.32
3054684	TX 1000-050	50		13200	195	145	0.11	1.37
3054685	TX 1000-063	63		13500	221	158	0.13	1.58
	TX 1000-750	75		13700	245	170	0.15	1.71
3054686	TX 1000-080	80		13800	255	175	0.16	1.73
3054687	TX 1000-100	100		14100	295	195	0.19	1.90
3054688	TX 1000-125	125		14300	345	220	0.23	2.11
	TX 1000-150	150		14500	395	245	0.27	2.32
3054689	TX 1000-160	160		14500	415	255	0.28	2.40
	TX 1000-175	175		14600	445	270	0.30	2.53
	TX 1000-200	200		14700	495	295	0.34	2.74
3054690	TX 1000-250	250		14800	595	345	0.42	2.16
	TX 1000-300	300		14900	695	395	0.49	3.58

* = at full stroke

Basic Information

For general information see "About gas springs", 2.1
 Pressure medium Nitrogen
 Max. charging pressure 150 bar (at 20°C)
 Min. charging pressure 25 bar (at 20°C)
 Operating temperature 0 to +80°C
 Force increase by temperature ±0.3%/°C
 Recommended max strokes/min ... ~ 50 to 100 (at 20°C)
 Max piston rod velocity 1.6 m/s

Rod surface Nitrided
 Tube surface Black oxide
 Repair kit 3023788
 Repair kit Volvo Part No 3054846

Mounting Possibilities

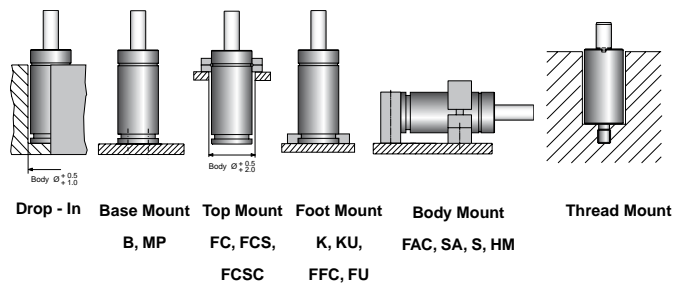

Note! For dimensions on mounting possibilities K, KU, FU, FAC, SA and HM refer to chapter 3.

MP
ISO

Note! Comes complete with screws to mount gas spring.

Order No.	a	b
MP-750	75	56.5

FC
ISO

Order No.	Ø a	Ø b	c	Ø d	e	f
FC-750	95	80	56.5	9	13	22

FCS
ISO

Volvo Part No.	Order No.	Ø a	b	c	Ø d	e	f
3044009	FCS-1500	104	90	73.5	11	16	29

FFC
ISO

Volvo Part No.	Order No.	a	b	Ø c	Ø d	e	f
3054001	FFC-1500	100	73.5	104	11	24	12

S
ISO

Note! Support S is designed to be used in combination with flanges mounted in the U or C groove or attachment B.

The mounting screw (M8) should be tightened with torque 25 Nm.

Volvo Part No.	Order No.	Ø a	b	c	d	e	f	g	Ø h
3044222	S-1500	75.4	22.5	52.5	52.5	160	137	11.5	11

Note! For dimensions on mounting possibilities K, KU, FU, FAC, SA and HM refer to chapter 3.

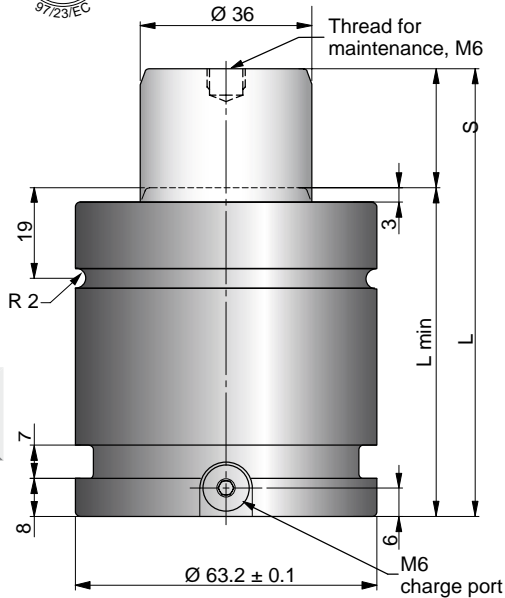

The Power Line series are our shortest and most powerful Piston Rod Sealed gas springs, giving you a great deal of force in a very small amount of space.

These gas springs are available with forces from 1700 N up to 200000 N and stroke lengths between 7 and 125 mm.

There is a side port for gas charging that can also be used to connect to a hose system.

An upper C-groove, lower U-groove together with two M8 threaded holes allow various mounting possibilities using our standard mounts.

6

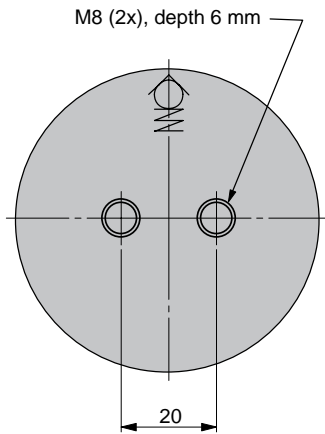

Order No.	S Stroke	Force in N at 150 bar/+20°C		L ±0.25	L min	Gas vol. (l)	Weight (kg)
		Initial	End force*				
X 1500-013	13	15000	24000	70	57	0.05	0.89
X 1500-016	16		24100	76	60	0.06	0.93
X 1500-019	19		24200	82	63	0.07	0.96
X 1500-025	25		24300	94	69	0.08	1.03
X 1500-032	32		23800	108	76	0.11	1.08
X 1500-038	38		23900	120	82	0.12	1.15
X 1500-050	50		24000	144	94	0.15	1.28
X 1500-063	63		24100	170	107	0.19	1.43
X 1500-075	75		24200	194	119	0.22	1.57
X 1500-080	80		24200	204	124	0.24	1.63
X 1500-100	100		24300	244	144	0.29	1.86
X 1500-125	125		24300	294	169	0.36	2.15

* = at full stroke

Basic Information

- For general information see "About gas springs", 2.1
- Pressure medium Nitrogen
- Max. charging pressure 150 bar (at 20°C)
- Min. charging pressure 25 bar (at 20°C)
- Operating temperature 0 to +80°C
- Force increase by temperature ±0.3%/°C
- Recommended max strokes/min ... ~ 50 to 100 (at 20°C)
- Max piston rod velocity 1.6 m/s
- Rod surface Nitrided
- Tube surface Black oxide
- Repair kit 3020434

Mounting Possibilities

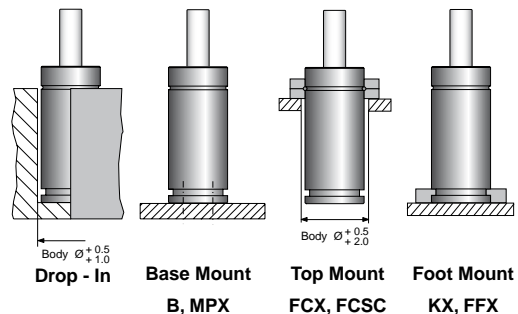

Note!
For dimensions on mounting possibility KX-1500 refer to Chapter 3.

MPX

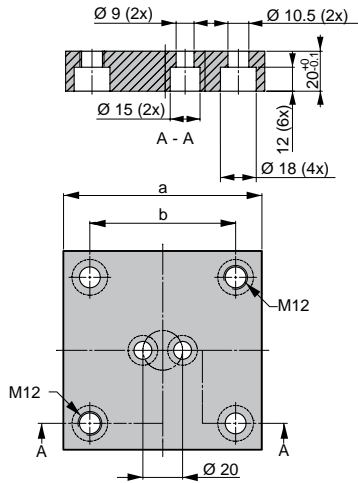

Note! Comes complete with screws to mount gas spring.

Order No.	a	b
MPX-1500	100	73.5

FCX

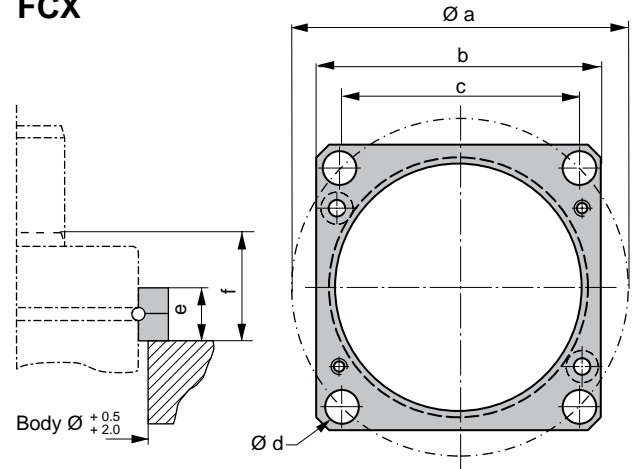

Order No.	Ø a	b	c	Ø d	e	f
FCX-1500	104	90	73.5	11	16	27

FFX

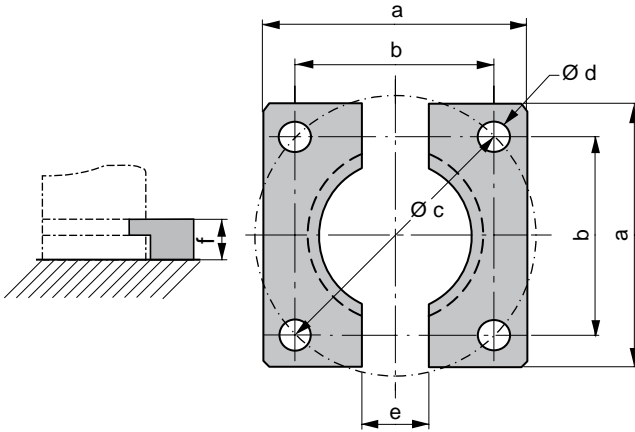

Order No.	a	b	Ø c	Ø d	e	f
FFX-1500	100	73.5	104	11	24	12

Note! For dimensions on mounting possibility KX-1500 refer to Chapter 3.

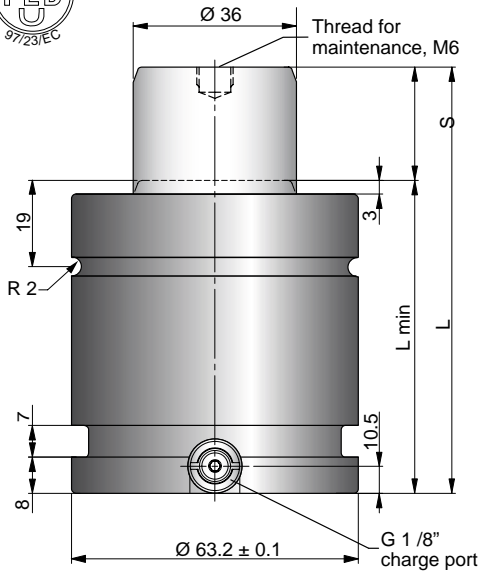

The Power Line series are our shortest and most powerful Piston Rod Sealed gas springs, giving you a great deal of force in a very small amount of space.

These gas springs are available with forces from 3500 N up to 66000 N and stroke lengths between 13 and 125 mm.

There is a side and a bottom port for gas charging that can also be used to connect to a hose system.

An upper C-groove, lower U-groove together with two M8 threaded holes allow various mounting possibilities using our standard mounts.

6

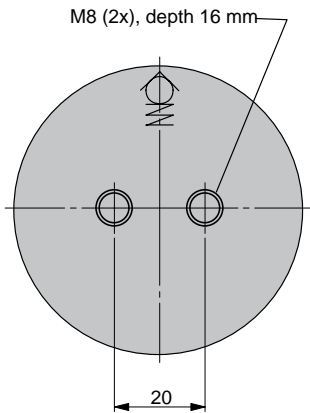

Order No.	S Stroke	Force in N at 150 bar/+20°C		L ±0.25	L min	Gas vol. (l)	Weight (kg)
		Initial	End force*				
XG 1500-013	13	15000	24000	78	65	0.05	0.9
XG 1500-016	16		24100	84	68	0.06	0.9
XG 1500-019	19		24200	90	71	0.07	1.0
XG 1500-025	25		24300	102	77	0.08	1.0
XG 1500-032	32		23800	116	84	0.11	1.1
XG 1500-038	38		23900	128	90	0.12	1.2
XG 1500-050	50		24000	152	102	0.15	1.3
XG 1500-063	63		24100	178	115	0.19	1.4
XG 1500-075	75		24200	202	127	0.22	1.4
XG 1500-080	80		24200	212	132	0.24	1.4
XG 1500-100	100		24300	252	152	0.29	1.9
XG 1500-125	125		24300	302	177	0.36	2.2

* = at full stroke

Basic Information

- For general information see "About gas springs", 2.1
- Pressure medium Nitrogen
- Max. charging pressure 150 bar (at 20°C)
- Min. charging pressure 25 bar (at 20°C)
- Operating temperature 0 to +80°C
- Force increase by temperature ±0.3%/°C
- Recommended max strokes/min ... ~ 50 to 100 (at 20°C)
- Max piston rod velocity 1.6 m/s
- Rod surface Nitrided
- Tube surface Black oxide
- Repair kit 3020434

Mounting Possibilities

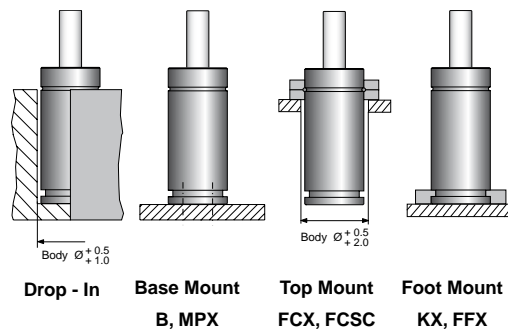

Note!

For dimensions on mounting possibility KX-1500 refer to Chapter 3.

MPX

Note! Comes complete with screws to mount gas spring.

Order No.	a	b
MPX-1500	100	73.5

FCX

Order No.	Ø a	b	c	Ø d	e	f
FCX-1500	104	90	73.5	11	16	27

6

FFX

Order No.	a	b	Ø c	Ø d	e	f
FFX-1500	100	73.5	104	11	24	12

Note! For dimensions on mounting possibility KX-1500 refer to Chapter 3.

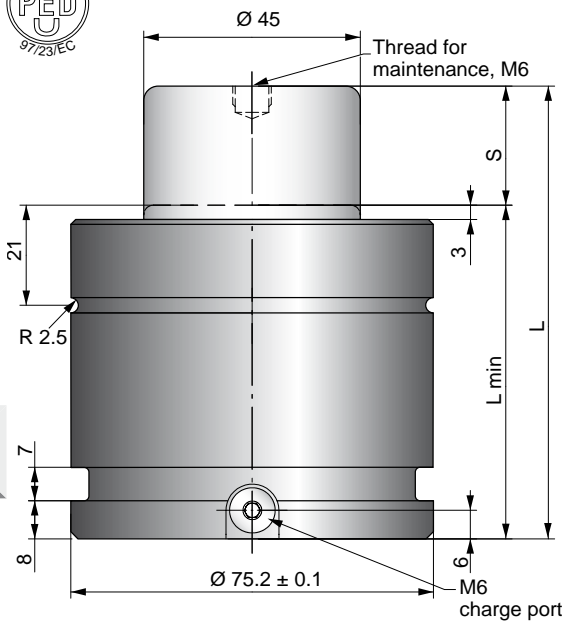

The Power Line series are our shortest and most powerful Piston Rod Sealed gas springs, giving you a great deal of force in a very small amount of space.

These gas springs are available with forces from 1700 N up to 200000 N and stroke lengths between 7 and 125 mm.

There is a side port for gas charging that can also be used to connect to a hose system.

An upper C-groove, lower U-groove together with four M8 threaded holes allow various mounting possibilities using our standard mounts.

6

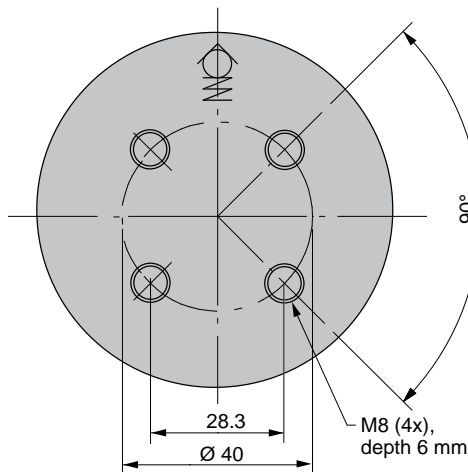

Volvo Part No.	Order No.	S Stroke	Force in N at 150 bar/+20°C		L ±0.25	L min	Gas vol. (l)	Weight (kg)
			Initial	End force*				
3050767	X 2400-016	16	24000	38300	77	61	0.09	1.34
3050768	X 2400-019	19		38500	83	64	0.10	1.38
3050769	X 2400-025	25		38700	95	70	0.13	1.45
3050770	X 2400-032	32		38600	109	77	0.16	1.56
3050771	X 2400-038	38		38400	121	83	0.18	1.65
3050772	X 2400-050	50		39200	145	95	0.23	1.84
3050773	X 2400-063	63		39200	171	108	0.28	2.20
3050774	X 2400-075	75		39200	195	120	0.33	2.26
3050775	X 2400-080	80		39200	205	125	0.35	2.32
3050776	X 2400-100	100		39300	245	145	0.43	2.66
3050777	X 2400-125	125		39300	295	170	0.54	3.05

* = at full stroke

Basic Information

- For general information see "About gas springs", 2.1
- Pressure medium Nitrogen
- Max. charging pressure 150 bar (at 20°C)
- Min. charging pressure 25 bar (at 20°C)
- Operating temperature 0 to +80°C
- Force increase by temperature ±0.3%/°C
- Recommended max strokes/min ... ~ 40 to 100 (at 20°C)
- Max piston rod velocity 1.6 m/s
- Rod surface Nitrided
- Tube surface Black oxide
- Repair kit 3018848

Repair kit Volvo Part No. 3050729

The X 2400-016 and X 2400-019 are not possible to repair.

Mounting Possibilities

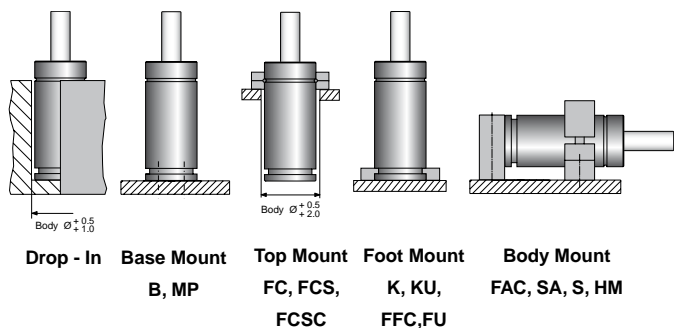

Note! For dimensions on mounting possibilities K-1500, KU-1500, FU-1500, FAC-1500, SA-1500, HM-1500 and FCSC-1500 refer to Chapter 3.

MP
ISO

Note! Comes complete with screws to mount gas spring.

Order No.	a	b
MP-1500	100	73.5

FC
ISO

Order No.	Ø a	Ø b	c	Ø d	e	f
FC-1500	122	104	73.5	11	16	29

FCS
ISO

Volvo Part No.	Order No.	Ø a	b	c	Ø d	e	f
3044009	FCS-1500	104	90	73.5	11	16	29

FFC
ISO

Volvo Part No.	Order No.	a	b	Ø c	Ø d	e	f
3054001	FFC-1500	100	73.5	104	11	24	12

S
ISO

Note! Support S is designed to be used in combination with flanges mounted in the U or C groove or attachment B.

The mounting screw (M10) should be tightened with torque 52 Nm.

Volvo Part No.	Order No.	Ø a	b	c	d	e	f	g	Ø h
3044222	S-1500	75.4	22.5	52.5	52.5	160	137	11.5	11

Note! For dimensions on mounting possibilities K-1500, KU-1500, FU-1500, FAC-1500, SA-1500, HM-1500 and FCSC-1500 refer to Chapter 3.



The Power Line series are our shortest and most powerful Piston Rod Sealed gas springs, giving you a great deal of force in a very small amount of space.

These gas springs are available with forces from 3500 N up to 66000 N and stroke lengths between 10 and 125 mm.

There is a side and bottom port for gas charging that can also be used to connect to a hose system.

An upper C-groove, lower U-groove together with four M8 threaded holes allow various mounting possibilities using our standard mounts.

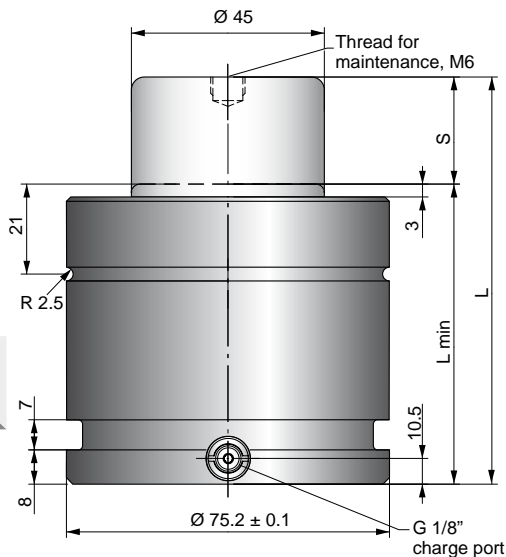

6

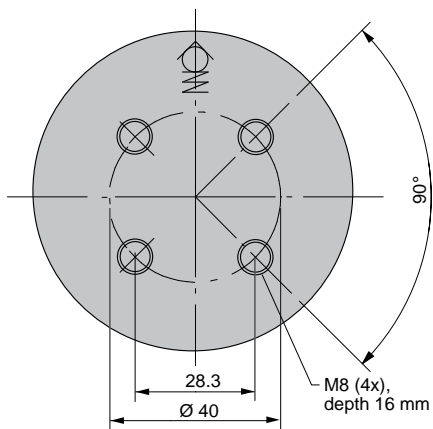

Order No.	S Stroke	Force in N at 150 bar/+20°C		L ±0.25	L min	Gas vol. (l)	Weight (kg)
		Initial	End force*				
XG 2400-016	16	24000	38300	91	75	0.09	1.77
XG 2400-019	19		38500	97	78	0.10	1.82
XG 2400-025	25		38700	109	84	0.13	1.89
XG 2400-032	32		38600	123	91	0.16	2.00
XG 2400-038	38		38400	135	97	0.18	2.10
XG 2400-050	50		39200	159	109	0.23	2.28
XG 2400-063	63		39200	185	122	0.28	2.56
XG 2400-075	75		39200	209	134	0.33	2.75
XG 2400-080	80		39200	219	139	0.35	2.83
XG 2400-100	100		39300	259	159	0.43	3.15
XG 2400-125	125		39300	309	184	0.54	3.54

* = at full stroke

Basic Information

For general information see "About gas springs", 2.1
 Pressure medium Nitrogen
 Max. charging pressure 150 bar (at 20°C)
 Min. charging pressure 25 bar (at 20°C)
 Operating temperature 0 to +80°C
 Force increase by temperature ±0.3%/°C
 Recommended max strokes/min ... ~ 40 to 100 (at 20°C)
 Max piston rod velocity 1.6 m/s

Rod surface Nitrided
 Tube surface Black oxide
 Repair kit 3018848

The XG 2400-16 and XG 2400-19 are not possible to repair using ordinary tools as the locking ring is difficult to remove.

Mounting Possibilities

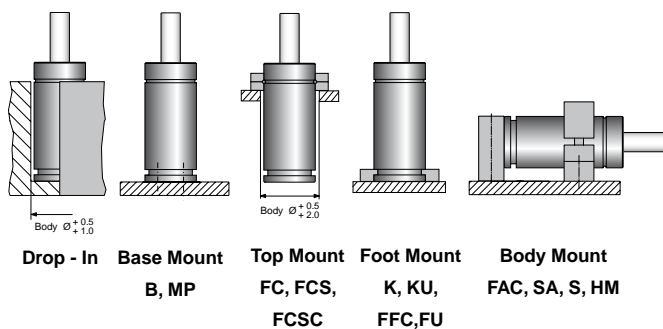

Note! For dimensions on mounting possibilities K, KU, FU, FAC, SA, FCSC and HM refer to chapter 3.

MP
ISO

Note! Comes complete with screws to mount gas spring.

Order No.	a	b
MP-1500	100	73.5

FC
ISO

Order No.	Ø a	Ø b	c	Ø d	e	f
FC-1500	122	104	73.5	11	16	29

FCS
ISO

Order No.	Ø a	b	c	Ø d	e	f
FCS-1500	104	90	73.5	11	16	29

FFC
ISO

Order No.	a	b	Ø c	Ø d	e	f
FFC-1500	100	73.5	104	11	24	12

S
ISO

Note! Support S is designed to be used in combination with flanges mounted in the U or C groove or attachment B.

The mounting screw (M10) should be tightened with torque 52 Nm.

Order No.	Ø a	b	c	d	e	f	g	Ø h
S-1500	75.4	22.5	52.5	52.5	160	137	11.5	11

Note! For dimensions on mounting possibilities K, KU, FU, FAC, SA, FCSC and HM refer to chapter 3.

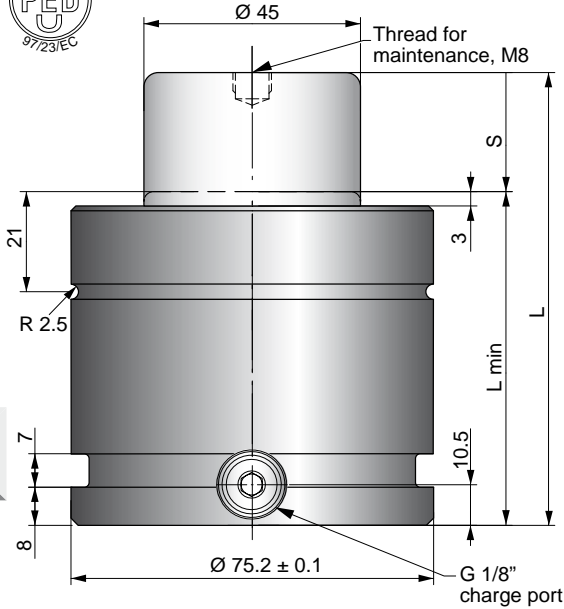

The Power Line - Heavy Duty series is a crossover between the standard TU series and Power Line X series.

These gas springs are available with forces from 9200 N up to 95000 N and stroke lengths between 13 and 300 mm.

There is an optional bottom port for hose/base plate connection.

An upper C-groove, lower U-groove and bottom threaded holes allow various mounting possibilities using our standard mounts.

6

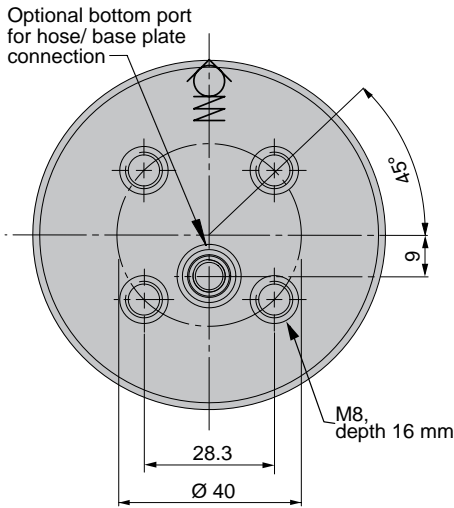

Volvo Part No.	Order No.	S Stroke	Force in N at 150 bar/+20°C		L ±0.25	L min	Gas vol. (l)	Weight (kg)
			Initial	End force*				
3054691	TX 2400-025	25	24000	37100	160	135	0.23	3.1
3054692	TX 2400-038	38		37600	186	148	0.28	3.31
3054693	TX 2400-050	50		37900	210	160	0.33	3.5
3054694	TX 2400-063	63		38100	236	173	0.38	3.7
	TX 2400-075	75		38300	260	185	0.43	3.89
3054695	TX 2400-080	80		38300	270	190	0.45	3.97
3054696	TX 2400-100	100		38500	310	210	0.53	4.29
3054697	TX 2400-125	125		38700	360	235	0.63	4.68
	TX 2400-150	150		38800	410	260	0.73	5.07
3054698	TX 2400-160	160		38800	430	270	0.77	5.23
	TX 2400-175	175		38900	460	285	0.83	5.47
	TX 2400-200	200		38900	510	310	0.93	5.86
3054699	TX 2400-250	250		39000	610	360	1.17	6.65
	TX 2400-300	300		39100	710	410	1.33	7.44

* = at full stroke

Basic Information

For general information see "About gas springs", 2.1
 Pressure medium Nitrogen
 Max. charging pressure 150 bar (at 20°C)
 Min. charging pressure 25 bar (at 20°C)
 Operating temperature 0 to +80°C
 Force increase by temperature ±0.3%/°C
 Recommended max strokes/min ... ~ 40 to 100 (at 20°C)
 Max piston rod velocity 1.6 m/s

Rod surface Nitrided
 Tube surface Black oxide
 Repair kit 3022952
 Repair kit Volvo Part No 3045847

Mounting Possibilities

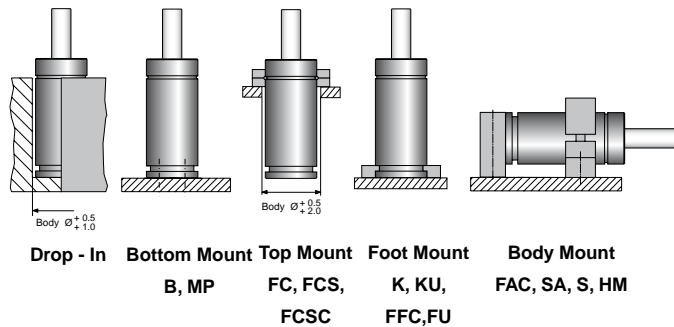

Note! For dimensions on mounting possibilities K, KU, FU, FAC, SA, FCSC and HM refer to chapter 3.

MP
ISO

Note! Comes complete with screws to mount gas spring.

Order No.	a	b
MP-1500	100	73.5

FC
ISO

Body $\varnothing \begin{smallmatrix} +0.5 \\ +2.0 \end{smallmatrix}$

Order No.	$\varnothing a$	$\varnothing b$	c	$\varnothing d$	e	f
FC-1500	122	104	73.5	11	16	29

FCS
ISO

Body $\varnothing \begin{smallmatrix} +0.5 \\ +2.0 \end{smallmatrix}$

Volvo Part No.	Order No.	$\varnothing a$	b	c	$\varnothing d$	e	f
3044009	FCS-1500	104	90	73.5	11	16	29

FFC
ISO

Volvo Part No.	Order No.	a	b	$\varnothing c$	$\varnothing d$	e	f
3054001	FFC-1500	100	73.5	104	11	24	12

S
ISO

Note! Support S is designed to be used in combination with flanges mounted in the U or C groove or attachment B.

The mounting screw (M10) should be tightened with torque 52 Nm.

Volvo Part No.	Order No.	$\varnothing a$	b	c	d	e	f	g	$\varnothing h$
3044222	S-1500	75.4	22.5	52.5	52.5	160	137	11.5	11

Note! For dimensions on mounting possibilities K, KU, FU, FAC, SA, FCSC and HM refer to chapter 3.

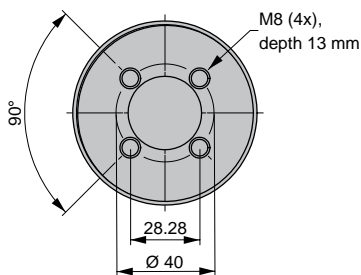
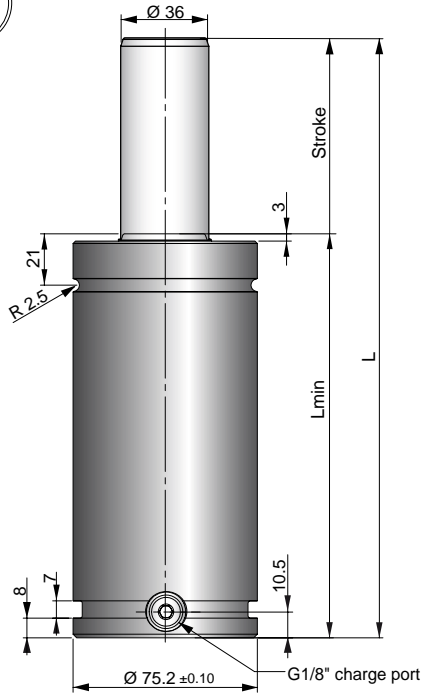

The TL series ranges from model sizes 750 to 5000, with the same features and technology as the TU series.

At the same time, the TL gas spring is shorter than the corresponding TU gas spring by 25 mm, except TL 5000 which is 37.5 mm shorter. TL springs share the same TU mounting possibilities and stroke lengths, with exception of strokes 12.5, 37.5 and 62.5.

6

Order No.	S Stroke	Force in N at 150 bar/+20°C		L ±0.25	L min	Gas vol. (l)	Weight (kg)
		Initial	End force*				
TL 1500-013	12.5	15200	18000	110	97.5	0.11	2.65
TL 1500-025	25		19200	135	110	0.15	2.88
TL 1500-038	37.5		2000	160	122.5	0.19	3.32
TL 1500-050	50		20400	185	135	0.23	3.34
TL 1500-063	62.5		20700	210	147.5	0.27	3.57
TL 1500-075	75		20900	235	160	0.31	3.80
TL 1500-080	80		21000	245	165	0.33	3.89
TL 1500-088	87.5		21100	260	172.5	0.35	4.33
TL 1500-100	100		21200	285	185	0.39	4.46
TL 1500-113	112.5		21400	310	197.5	0.43	4.78
TL 1500-125	125		21500	335	210	0.47	4.72
TL 1500-138	137.5		22000	360	222.5	0.49	5.82
TL 1500-150	150		22000	385	235	0.52	5.17
TL 1500-160	160		22100	405	245	0.56	5.82
TL 1500-175	175		22100	435	260	0.60	6.55
TL 1500-200	200		22100	485	285	0.68	6.55
TL 1500-225	225	22200	535	310	0.76	6.55	
TL 1500-250	250	22200	585	335	0.84	7.46	

* = at full stroke

Basic Information

- For general information see "About gas springs", 2.1
- Pressure medium Nitrogen
- Max. charging pressure 150 bar
- Min. charging pressure..... 25 bar
- Operating temperature 0 to +80°C
- Force increase by temperature ±0.3%/°C
- Recommended max strokes/min ~ 15-40 (at 20°C)
- Max piston rod velocity 1.6 m/s

- Rod surface..... Nitrided
- Tube surface Black oxide
- Repair kit..... 3019278

Mounting Possibilities

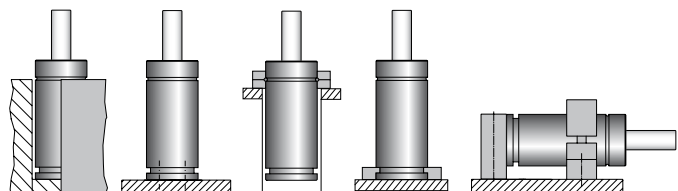

- Drop - In**
- Base Mount**
B, MP
- Top Mount**
FC, FCS,
FCSC
- Foot Mount**
K, KU, FFC,
FU
- Body Mount**
FAC, SA, S, HM

Note! For dimensions on mounting possibilities K-1500, KU-1500, FU-1500, FAC-1500, SA-1500, HM-1500 and FCSC-1500 refer to Chapter 3.

MP

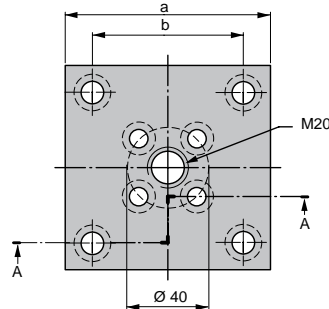
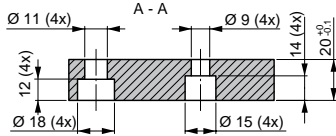

Note! Comes complete with screws to mount gas spring.

Order No.	a	b
MP-1500	100	73.5

FC

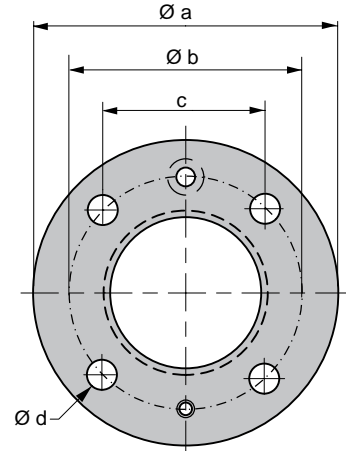
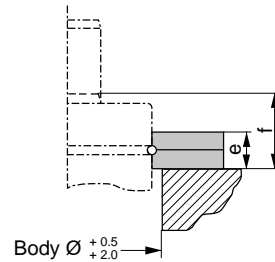

Order No.	Ø a	Ø b	c	Ø d	e	f
FC-1500	122	104	73.5	11	16	29

FCS

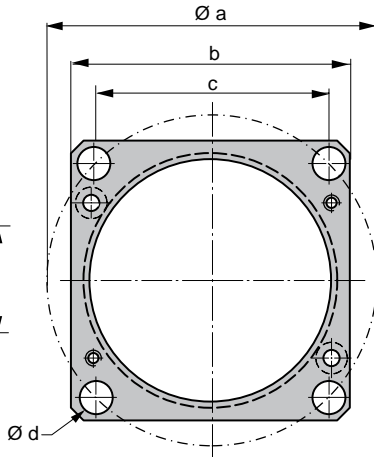
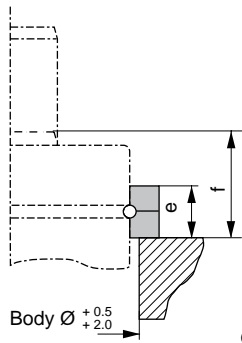

Order No.	Ø a	b	c	Ø d	e	f
FCS-1500	104	90	73.5	11	16	29

FFC

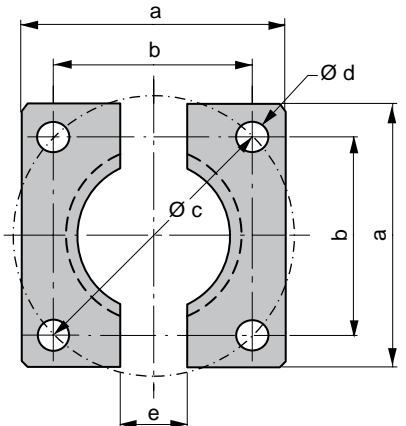
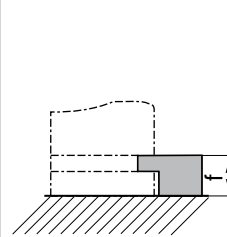

Order No.	a	b	Ø c	Ø d	e	f
FFC-1500	100	73.5	104	11	24	12

S



Note! Support S is designed to be used in combination with flanges mounted in the U or C groove or mounting option B.

The mounting screw (M10) should be tightened with torque 52 Nm.

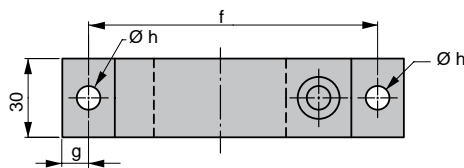
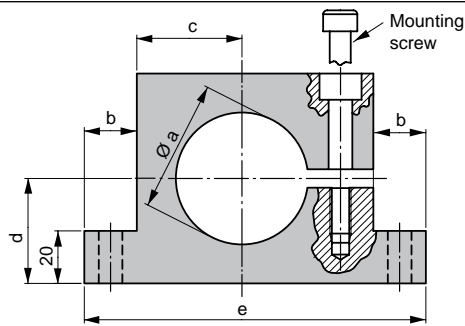

Order No.	Ø a	b	c	d	e	f	g	Ø h
S-1500	75.4	22.5	52.5	52.5	160	137	11.5	11

Note! For dimensions on mounting possibilities K-1500, KU-1500, FU-1500, FAC-1500, SA-1500, HM-1500 and FCSC-1500 refer to Chapter 3.



This is a short height hoseable spring with an initial force of 15000 N.

The K 1500 has a total length of 60 mm + (2 x stroke). This spring is 50 mm shorter than the TU 1500.

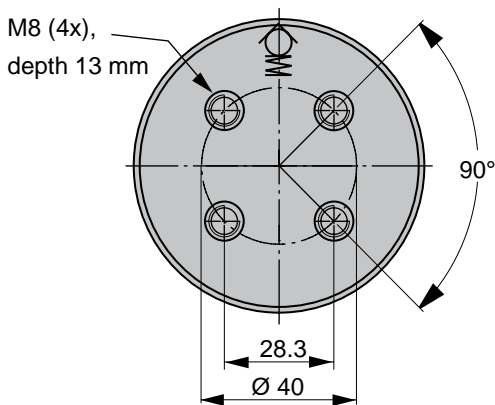
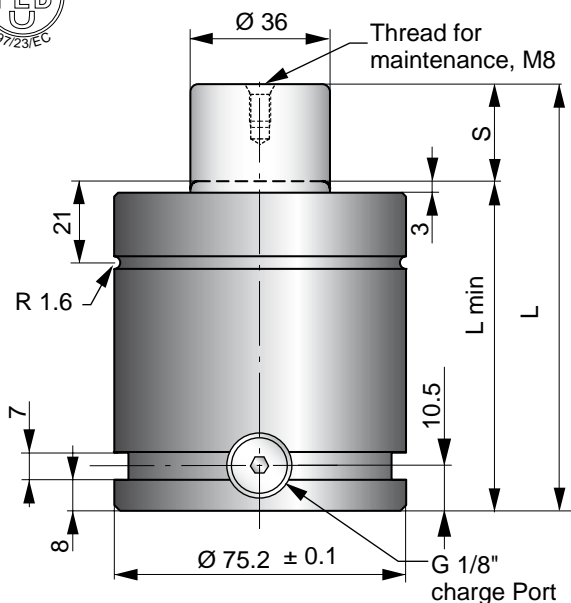

Order No.	S Stroke	Force in N at 150 bar/+20°C		L ±0.25	L min	Gas vol. (l)	Weight (kg)
		Initial	End force*				
K 1500-025	25	15000	24000	110	85	0.10	2.05
K 1500-038	38.1		23000	136.2	98.1	0.14	2.35
K 1500-050	50		23000	160	110	0.18	2.50
K 1500-064	63.5		23000	187	123.5	0.22	2.75
K 1500-080	80		23000	220	140	0.27	3.05
K 1500-100	100		23000	260	160	0.34	3.40

* = at full stroke

Basic Information

For general information see "About gas springs", 2.1
 Pressure medium Nitrogen
 Max. charging pressure 150 bar
 Min. charging pressure 25 bar
 Operating temperature 0 to +80°C
 Force increase by temperature ±0.3%/°C
 Recommended max strokes/min ... ~ 15-40 (at 20°C)
 Max piston rod velocity 1.6 m/s

Rod surface..... Nitrided
 Tube surface Black oxide
 Repair kit 3017230

Mounting Possibilities

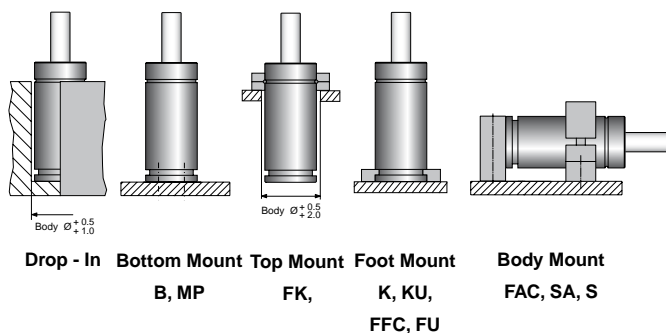

Note! For dimensions on mounting possibilities K-1500, KU-1500, FU-1500, FAC-1500, SA-1500 and FCSC-1500 refer to Chapter 3.

MP
ISO

Note! Comes complete with screws to mount gas spring.

Order No.	a	b
MP-1500	100	73.5

FK

Order No.	Ø a	b	c	Ø d	e	f
FK-1500	104	90	73.5	11	16	29

FFC
ISO

Order No.	a	b	Ø c	Ø d	e	f
FFC-1500	100	73.5	104	11	24	12

S
ISO

Note! Support S is designed to be used in combination with flanges mounted in the U or C groove or mounting option B.

The mounting screw (M10) should be tightened with torque 52 Nm.

Order No.	Ø a	b	c	d	e	f	g	Ø h
S-1500	75.4	22.5	52.5	52.5	160	137	11.5	11

Note! For dimensions on mounting possibilities K-1500, KU-1500, FU-1500, FAC-1500, SA-1500 and FCSC-1500 refer to Chapter 3.

TU 1500

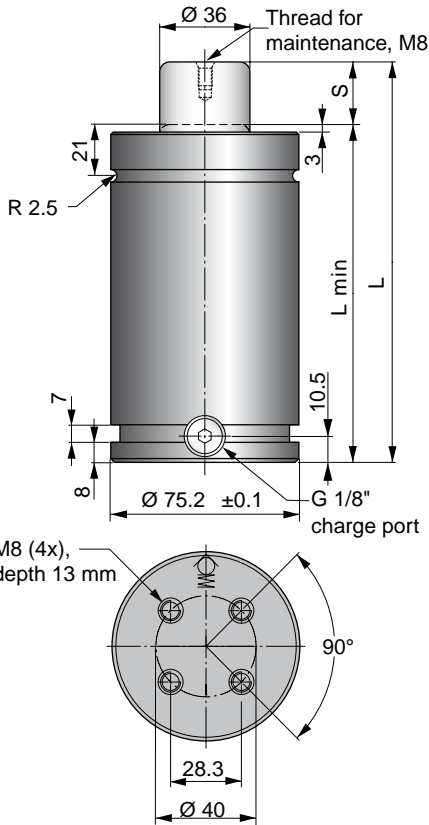

The standard line of gas springs is the TU line. Sizes 250 to 10000 correspond to the ISO 11901 standard for gas springs.

Sizes 750 to 7500 correspond to FORD's, GM's and Renault's automotive gas spring standards. When ordering a Renault standard gas spring add an R to the Order No. (for example: TUR 1500-xxx).

TUR will be replaced by TUS

6

Being phased out!

TU, TUR och LCF 1500 gas springs are also available with double charging ports. When ordering this type, add a D to the Order No.

For example: TUD 1500-xxx **TUD 1500 example**

Note! TUD, TURD and LCFD 1500 gas springs contain no valve and can only be pressurised through connection to a hose system and therefore are always delivered uncharged.

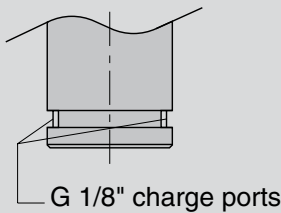

TUR will be replaced by TUS

Volvo Part No.	Order No.	S Stroke	Force in N at 150 bar/+20°C		L ±0.25	L ISO min	Gas (l)	Weight (kg)	
			Initial	End force*					
9975957	TU 1500-025	25	15000	23000	160	135	0.10	3.65	✓
3044187	TU 1500-038	38.1			186.2	148.1	0.15	3.89	
9975958	TU 1500-050	50			210	160	0.18	4.11	✓
3044188	TU 1500-064	63.5			237	173.5	0.22	4.35	
9975959	TU 1500-080	80			270	190	0.28	4.66	✓
9975960	TU 1500-100	100			310	210	0.34	5.02	✓
9975961	TU 1500-125	125			360	235	0.42	5.48	✓
9975962	TU 1500-160	160			430	270	0.53	6.12	✓
	TU 1500-200	200			510	310	0.68	6.86	
	TU 1500-250	250			610	360	0.81	7.77	
	TU 1500-300	300	710	410	0.96	8.69			

* = at full stroke

Basic Information

- For general information see "About gas springs", 2.1
- Pressure medium Nitrogen
- Max. charging pressure 150 bar
- Min. charging pressure..... 25 bar
- Operating temperature 0 to +80°C
- Force increase by temperature ±0.3%/°C
- Recommended max strokes/min ~ 15-40 (at 20°C)
- Max piston rod velocity 1.6 m/s

- Rod surface..... Nitrided
- Tube surface Black oxide
- Repair kit..... 2014068-02
- Repair kit Volvo Part No 3040924

Mounting Possibilities

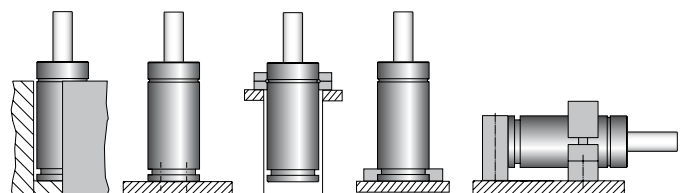

- Drop - In**
- Base Mount**
B, MP
- Top Mount**
FC, FCS, FCSC
- Foot Mount**
K, KU, FFC, FU
- Body Mount**
FAC, SA, S, HM

Note! For dimensions on mounting possibilities K-1500, KU-1500, FU-1500, FAC-1500, SA-1500, HM-1500 and FCSC-1500 refer to Chapter 3.

MP
ISO

Note! Comes complete with screws to mount gas spring.

Order No.	a	b
MP-1500	100	73.5

FC
ISO

Order No.	Ø a	Ø b	c	Ø d	e	f
FC-1500	122	104	73.5	11	16	29

FCS
ISO

Volvo Part No.	Order No.	Ø a	b	c	Ø d	e	f
3044009	FCS-1500	104	90	73.5	11	16	29

FFC
ISO

Volvo Part No.	Order No.	a	b	Ø c	Ø d	e	f
3054001	FFC-1500	100	73.5	104	11	24	12

S
ISO

Note! Support S is designed to be used in combination with flanges mounted in the U or C groove or mounting option B.

The mounting screw (M10) should be tightened with torque 52 Nm.

Volvo Part No.	Order No.	Ø a	b	c	d	e	f	g	Ø h
3044222	S-1500	75.4	22.5	52.5	52.5	160	137	11.5	11

Note! For dimensions on mounting possibilities K-1500, KU-1500, FU-1500, FAC-1500, SA-1500, HM-1500 and FCSC-1500 refer to Chapter 3.

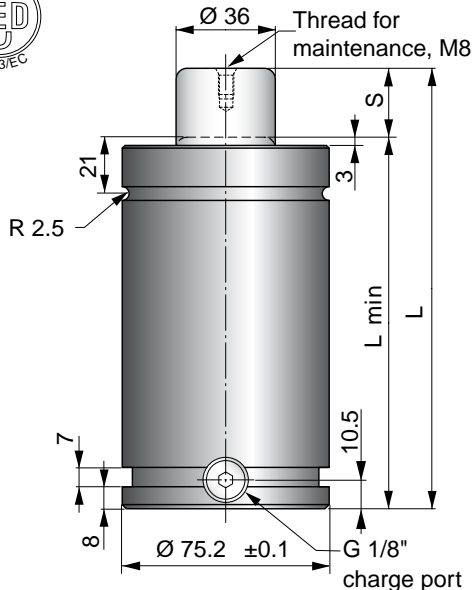

The High Speed gas springs (TUS) are engineered to withstand press stroke speeds to a maximum 2 m/s, which meet the safety demands from the French automotive manufacturer Renault.

These gas springs are available in sizes 750 to 7500 and dimensions correspond to the ISO 11901 standard for gas springs.

TUS gas spring will replace TUR that is being phased out.

6

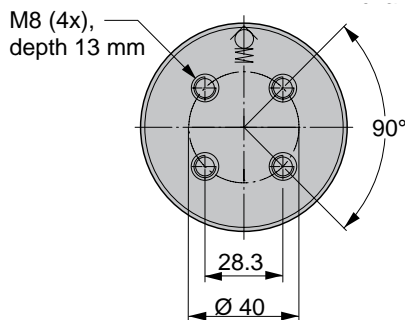

Order No.	S Stroke	Force in N at 150 bar/+20°C		L ±0.25	L min	Gas vol. (l)	Weight (kg)
		Initial	End force*				
TUS 1500-025	25	15000	23000	160	135	0.10	3.75
TUS 1500-038	38.1		23000	186.2	148.1	0.15	3.95
TUS 1500-050	50		23000	210	160	0.18	4.15
TUS 1500-064	63.5		23000	237	173.5	0.22	4.40
TUS 1500-080	80		23000	270	190	0.28	4.70
TUS 1500-100	100		23000	310	210	0.34	5.10
TUS 1500-125	125		23000	360	235	0.42	5.55
TUS 1500-160	160		23000	430	270	0.53	6.25
TUS 1500-200	200		23000	510	310	0.68	6.90
TUS 1500-250	250		23000	610	360	0.81	7.80
TUS 1500-300	300		23000	710	410	0.96	8.90

* = at full stroke

Basic Information

For general information see "About gas springs", 2.1
 Pressure medium Nitrogen
 Max. charging pressure 150 bar
 Min. charging pressure..... 25 bar
 Operating temperature 0 to +80°C
 Force increase by temperature ±0.3%/°C
 Recommended max strokes/min ~ 15-40 (at 20°C)
 Max piston rod velocity 2 m/s

Rod surface..... Nitrided
 Tube surface Black oxide
 Repair kit..... 3019278

Mounting Possibilities

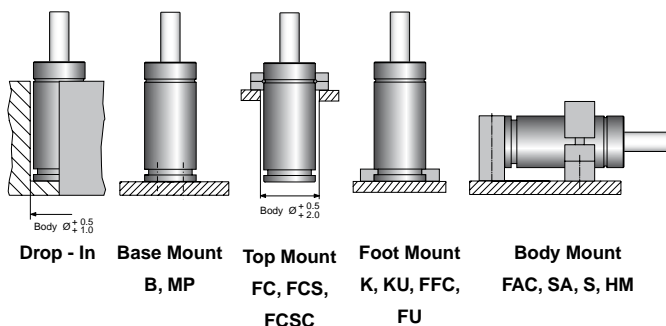

Note! For dimensions on mounting possibilities K-1500, KU-1500, FU-1500, FAC-1500, SA-1500, HM-1500 and FCSC-1500 refer to Chapter 3.

MP
ISO

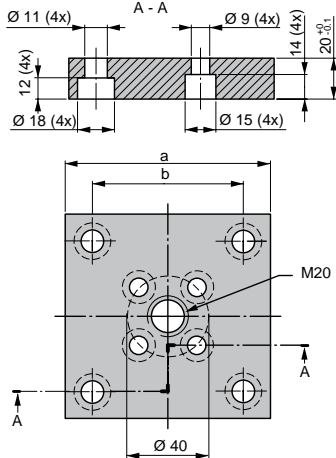

Note! Comes complete with screws to mount gas spring.

Order No.	a	b
MP-1500	100	73.5

FC
ISO

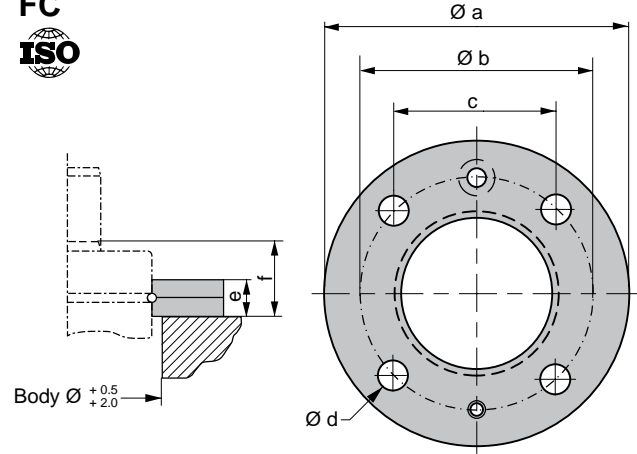

Order No.	Ø a	Ø b	c	Ø d	e	f
FC-1500	122	104	73.5	11	16	29

FCS
ISO

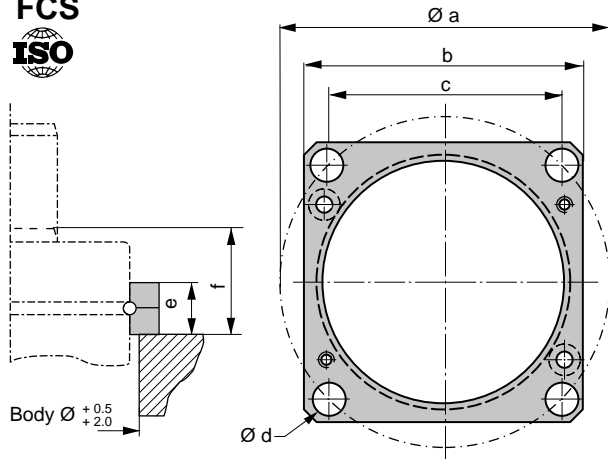

Order No.	Ø a	b	c	Ø d	e	f
FCS-1500	104	90	73.5	11	16	29

FFC
ISO

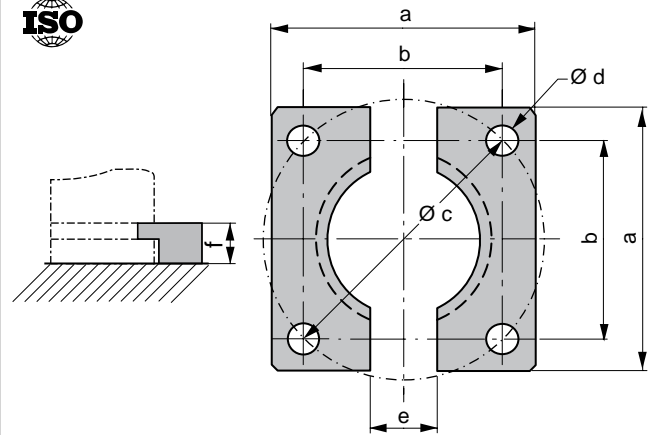

Order No.	a	b	Ø c	Ø d	e	f
FFC-1500	100	73.5	104	11	24	12

S
ISO

Note! Support S is designed to be used in combination with flanges mounted in the U or C groove or mounting option B.

The mounting screw (M10) should be tightened with torque 52 Nm.

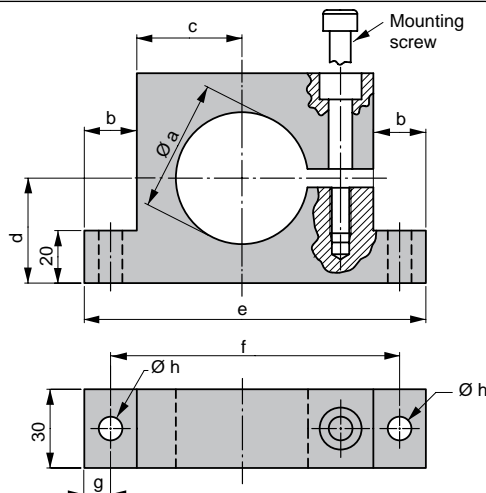

Order No.	Ø a	b	c	d	e	f	g	Ø h
S-1500	75.4	22.5	52.5	52.5	160	137	11.5	11

Note! For dimensions on mounting possibilities K-1500, KU-1500, FU-1500, FAC-1500, SA-1500, HM-1500 and FCSC-1500 refer to Chapter 3.

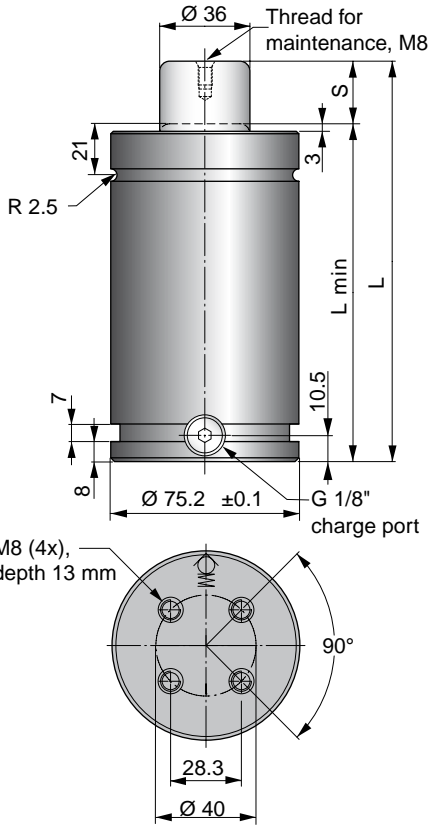

Low Contact Force (LCF) gas springs are designed to reduce excessive shock loads, high noise levels and extreme pad bounce, all factors that lead to high press maintenance costs and noise pollution.

6

Force vs Stroke for LCF 1500 Springs

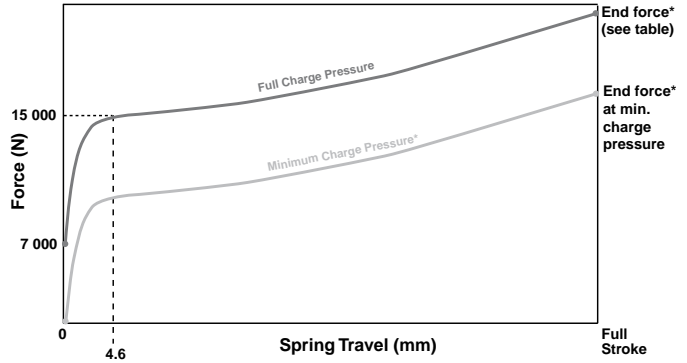

Being phased out!

TU, TUR och LCF 1500 gas springs are also available with double charging ports. When ordering this type, add a D to the Order No.

For example:
LCFD 1500-xxx

Note! TUD, TURD and LCFD 1500 gas springs contain no valve and can only be pressurised through connection to a hose system and therefore are always delivered uncharged.

LCFD 1500 example

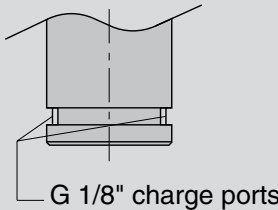

Volvo Part No.	Order No.	S Stroke	Force in N at 150 bar/+20°C		L ±0.25	L min	Gas vol. (l)	Weight (kg)
			Initial	End force*				
	LCF 1500-025	25	15000	23000	160	135	0.10	3.75
	LCF 1500-038	38.1		23000	186.2	148.1	0.15	3.95
	LCF 1500-050	50		23000	210	160	0.18	4.15
	LCF 1500-064	63.5		23000	237	173.5	0.22	4.40
	LCF 1500-080	80		23000	270	190	0.28	4.70
	LCF 1500-100	100		23000	310	210	0.34	5.10
	LCF 1500-125	125		23000	360	235	0.42	5.55
	LCF 1500-160	160		23000	430	270	0.53	6.25
3055036	LCF 1500-200	200		23000	510	310	0.68	6.90
	LCF 1500-250	250		23000	610	360	0.81	7.80
	LCF 1500-300	300	23000	710	410	0.96	8.90	

* = at full stroke

Basic Information

Mounting Possibilities

- For general information see "About gas springs", 2.1
- Pressure medium Nitrogen
- Max. charging pressure 150 bar
- Min. charging pressure..... 105 bar
- Operating temperature 0 to +80°C
- Force increase by temperature ±0.3%/°C
- Recommended max strokes/min ~ 15-40 (at 20°C)
- Max piston rod velocity 1.6 m/s

- Rod surface..... Nitrided
- Tube surface Black oxide
- Repair kit..... 3019378

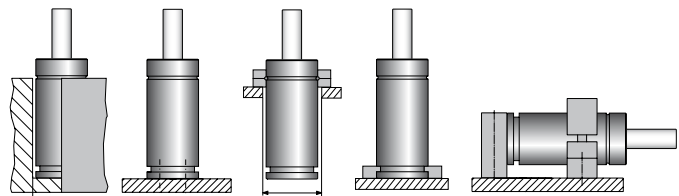

- Drop - In**
- Base Mount**
B, MP
- Top Mount**
FC, FCS, FCSC
- Foot Mount**
K, KU, FFC, FU
- Body Mount**
FAC, SA, S, HM

Note! For dimensions on mounting possibilities K-1500, KU-1500, FU-1500, FAC-1500, SA-1500, HM-1500 and FCSC-1500 refer to Chapter 3.

MP
ISO

Note! Comes complete with screws to mount gas spring.

Order No.	a	b
MP-1500	100	73.5

FC
ISO

Order No.	Ø a	Ø b	c	Ø d	e	f
FC-1500	122	104	73.5	11	16	29

FCS
ISO

Volvo Part No.	Order No.	Ø a	b	c	Ø d	e	f
3044009	FCS-1500	104	90	73.5	11	16	29

FFC
ISO

Volvo Part No.	Order No.	a	b	Ø c	Ø d	e	f
3054001	FFC-1500	100	73.5	104	11	24	12

S
ISO

Note! Support S is designed to be used in combination with flanges mounted in the U or C groove or mounting option B.

The mounting screw (M10) should be tightened with torque 52 Nm.

Volvo Part No.	Order No.	Ø a	b	c	d	e	f	g	Ø h
3044222	S-1500	75.4	22.5	52.5	52.5	160	137	11.5	11

Note! For dimensions on mounting possibilities K-1500, KU-1500, FU-1500, FAC-1500, SA-1500, HM-1500 and FCSC-1500 refer to Chapter 3.

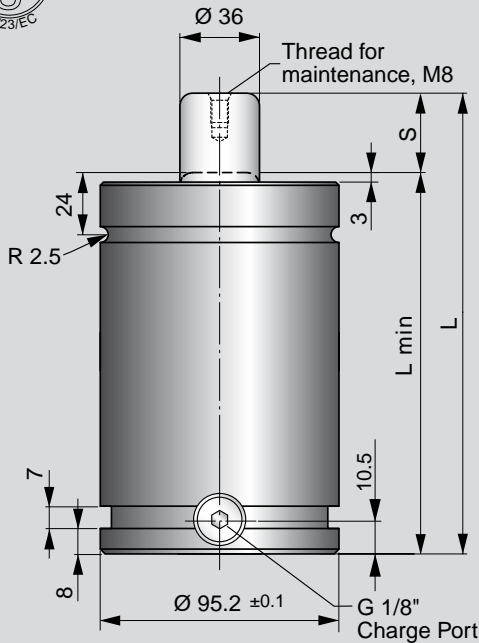

TB springs have a larger gas volume than our standard TU series. This reduces the pressure increase as the piston rod is stroked. It also increases the service life of the spring.

TB springs are recommended for applications where a low force increase is desirable. TB springs are also a good choice for higher cycle rates and high volume production.

Note! When ordering mounts for TB 1500 springs, a mount of a larger size than the spring must be used.

6

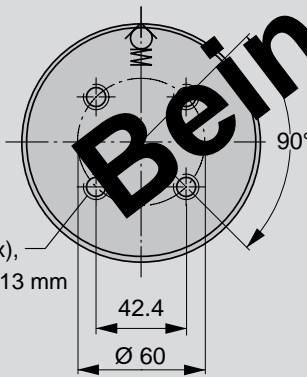

Volvo Part No.	Order No.	S Stroke	Force in N at 150 bar/+20°C		L ±0.25	L min	Gas vol. (l)	Weight (kg)
			Initial	End-force*				
3044148	TB 1500-025	25	15000	19000	160	135	0.17	6.05
3044149	TB 1500-038	38.1		19000	186.2	148.1	0.23	6.25
3044150	TB 1500-050	50		19000	210	160	0.29	6.65
3044151	TB 1500-064	63.5		19000	237	173.5	0.36	6.95
3044152	TB 1500-080	80		19000	270	190	0.44	7.35
3044153	TB 1500-100	100		19000	310	210	0.54	7.90
3044154	TB 1500-125	125		19000	360	235	0.67	8.45
3044155	TB 1500-160	160		19000	430	270	0.85	9.35
	TB 1500-200	200		19000	510	310	1.05	10.25
	TB 1500-250	250		19000	610	360	1.30	11.45
	TB 1500-300	300	19000	710	410	1.55	12.65	

* = at full stroke

Basic Information

- For general information see "About gas springs", 2.1
- Pressure medium Nitrogen
- Max. charging pressure 150 bar
- Min. charging pressure 25 bar
- Operating temperature 0 to +80°C
- Force increase by temperature ±0.3%/°C
- Recommended max strokes/min ~ 40-80 (at 20°C)
- Max piston rod velocity 1.6 m/s
- Rod surface Nitrided
- Tube surface Black oxide
- Repair kits
- * TB 1500 new version 3019236
- TB 1500 Volvo Part No 3050723
- * TB 1500 old version 2014068-06
- TB 1500 Volvo Part No 3044229
- *New version is identified by circular rings on the top of tube, guide and rod.

Mounting Possibilities

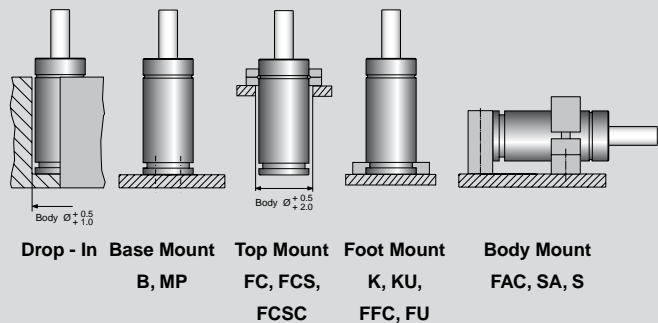

Note! For dimension on mounting possibilities K-3000, KU-3000, FU-3000, FAC-3000, SA-3000 and FCSC-3000 refer to Chapter 3.

MP

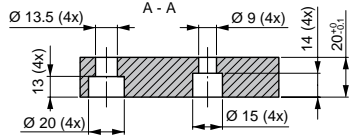

Note! Comes complete with screws to mount gas spring.

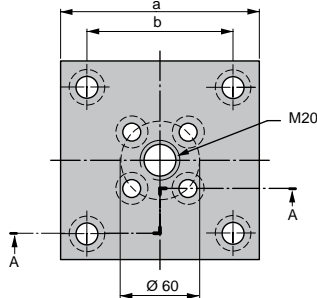

Order No.	a	b
MP-3000	120	92

FC

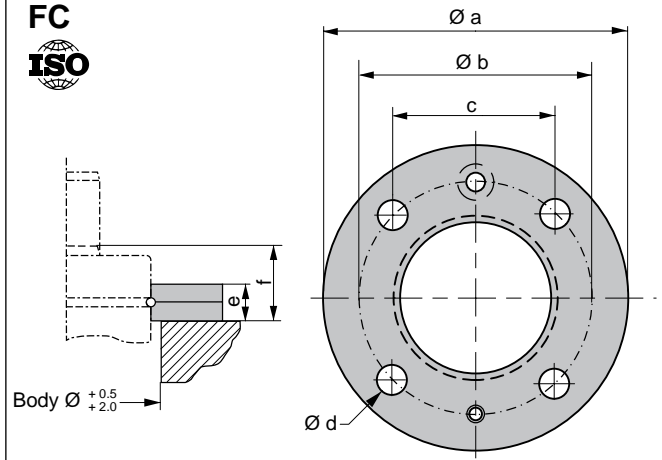

Order No.	Ø a	Ø b	c	Ø d	e	f
FC-3000	150	130	92	13.5	18	33

FCS

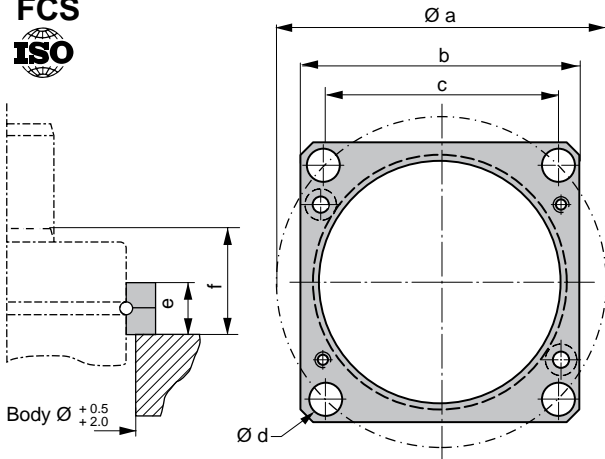

Volvo Part No.	Order No.	Ø a	b	c	Ø d	e	f
3044009	FCS-1500	104	90	73.5	11	16	29

FFC

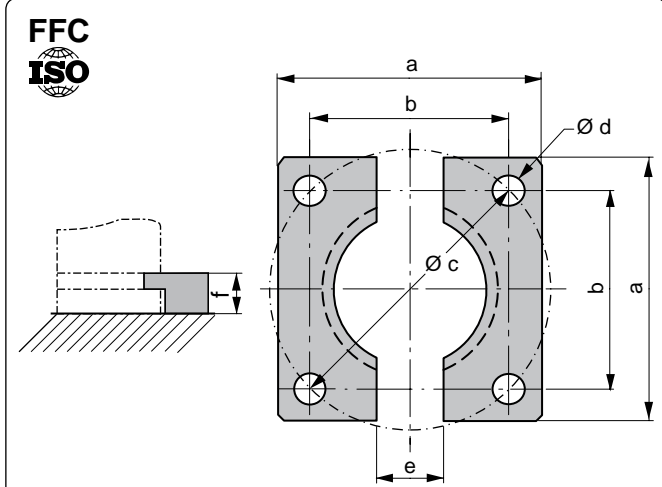

Volvo Part No.	Order No.	a	b	Ø c	Ø d	e	f
3054001	FFC-1500	100	73.5	104	11	24	12

S

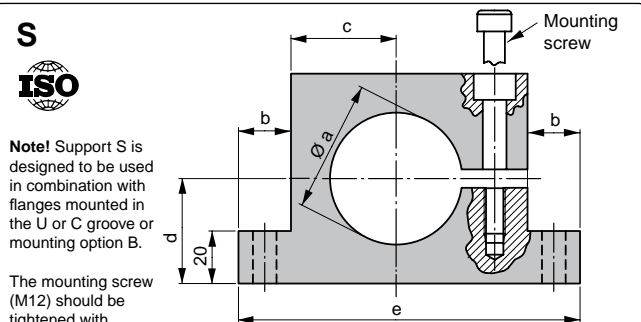

Note! Support S is designed to be used in combination with flanges mounted in the U or C groove or mounting option B.

The mounting screw (M12) should be tightened with torque 91 Nm.

Volvo Part No.	Order No.	Ø a	b	c	d	e	f	g	Ø h
3044222	S-1500	75.4	22.5	52.5	52.5	160	137	11.5	11

Note! For dimension on mounting possibilities K-3000, KU-3000, FU-3000, FAC-3000, SA-3000 and FCSC-3000 refer to Chapter 3.

SL 1500

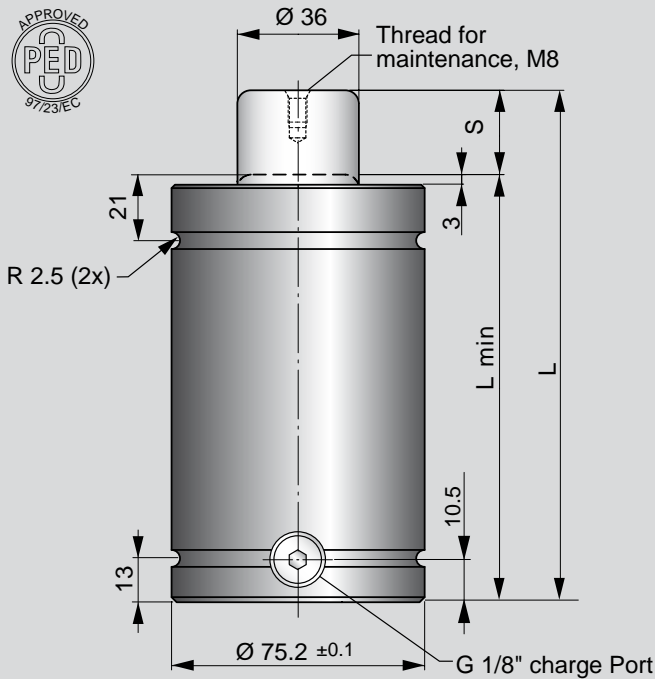

This 1500 spring has "inch-based" total length and stroke length.

The SL 1500 has a total length of 101.6 mm + (2 x stroke).

6

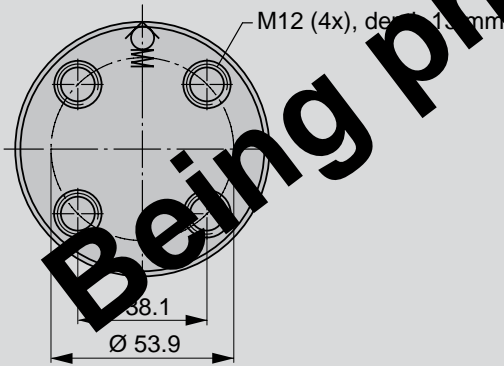

Being phased out!

Ord. No.	S Stroke	Force in N at 150 bar/+20°C		L ±0.25	L min	Gas vol. (l)	Weight (kg)
		Initial	End force*				
SL 1500-013	12.7	15000	25000	127	114.3	0.06	3.21
SL 1500-025	25.4		22000	152.4	127	0.10	3.45
SL 1500-038	38.1		22000	177.8	139.7	0.14	3.68
SL 1500-051	50.8		22000	203.2	152.4	0.18	3.91
SL 1500-064	63.5		22000	228.6	165.1	0.22	4.15
SL 1500-076	76.2		22000	254	177.8	0.26	4.38
SL 1500-089	88.9		22000	279.4	190.5	0.30	4.61
SL 1500-102	101.6		23000	304.8	203.2	0.34	4.84
SL 1500-114	114.3		23000	330.2	215.9	0.38	5.08
SL 1500-127	127		23000	355.6	228.6	0.42	5.31
SL 1500-140	139.7		23000	381	241.3	0.46	5.54
SL 1500-152	152.4		23000	406.4	254	0.50	5.78

* = at full stroke

Basic Information

- For general information see "About gas springs", 2.1
- Pressure medium Nitrogen
- Max. charging pressure 150 bar
- Min. charging pressure 25 bar
- Operating temperature 0 to +80°C
- Force increase by temperature ±0.3%/°C
- Recommended max strokes/min ~ 15-40 (at 20°C)
- Max piston rod velocity 1.6 m/s
- Rod surface Nitrided
- Tube surface Yellow chromed
- Repair kits
- SL 1500 2014979-1500

Mounting Possibilities

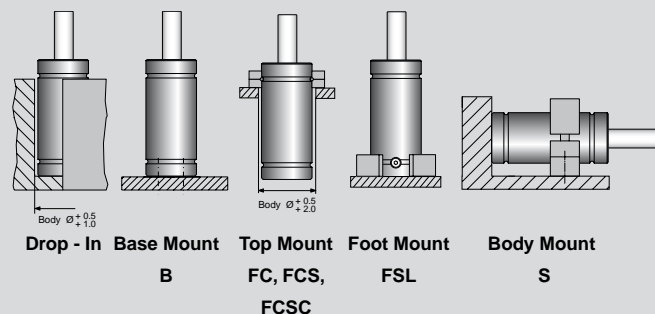

Note! For dimensions on mounting possibility FCSC-1500 refer to Chapter 3.

FC
ISO

Order No.	Ø a	Ø b	c	Ø d	e	f
FC-1500	122	104	73.5	11	16	29

FCS
ISO

Order No.	Ø a	b	c	Ø d	e	f
FCS-1500	104	90	73.5	11	16	29

FSL

Order No.	a	b	Ø c	d	Ø e	Ø f	g	h	i	j
FSL-1500	101.6	76.2	107.8	49	20	13.5	13	25	25.7	25.7

S
ISO

Note! Support S is designed to be used in combination with flanges mounted in the C groove or mounting option B.

The mounting screw (M10) should be tightened with torque 52 Nm.

Order No.	Ø a	b	c	d	e	f	g	Ø h
S-1500	75.4	22.5	52.5	52.5	160	137	11.5	11

Note! For dimension on mounting possibility FCSC-1500 refer to Chapter 3.

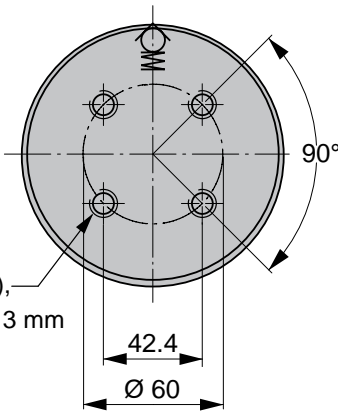
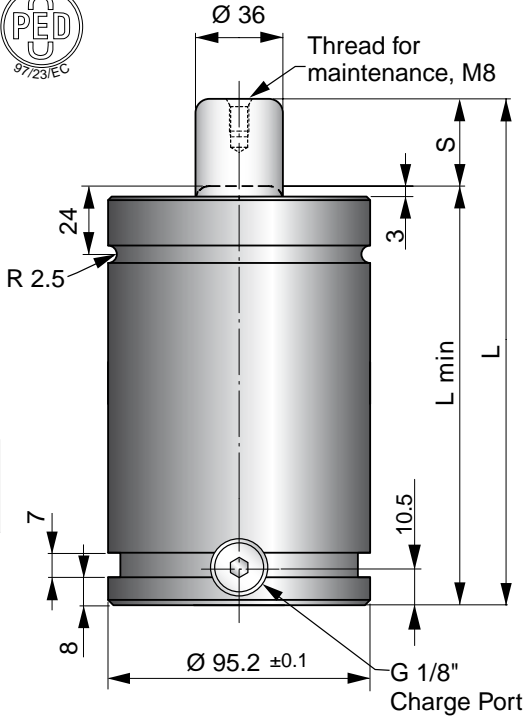

Speed Control™ – SPC gas springs have been engineered to eliminate blank holder bounce, commonly associated with increased return stroke speeds from link drive presses.

SPC gas springs have inbuilt return stroke **speed dampening**, which decelerates the last 30 mm of piston rod stroke to 0.4 m/s, helping to bring the blank holder to a smooth stop.

Speed Control™ – SPC features:

- Eliminate blank holder bounce
- Increase productivity by increasing part transfer efficiency
- Easily retrofitted to existing dies
- Stroke lengths 125 to 300 mm
- Linkable using hose-system

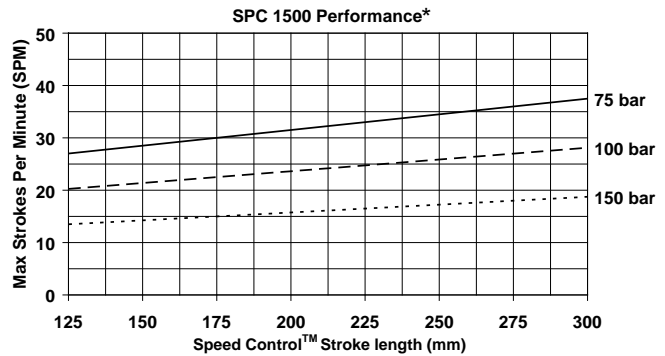

*At ambient room temperatures with free air flow

Order No.	S Stroke	Force in N at 150 bar/+20°C		L ±0.25	L min	Gas vol. (l)	Weight (kg)
		Initial	End force*				
SPC 1500-125	125	15000	19000	370	245	0.73	7.60
SPC 1500-160	160			440	280	0.91	8.45
SPC 1500-200	200			520	320	1.11	9.43
SPC 1500-250	250			620	370	1.36	10.64
SPC 1500-300	300			720	420	1.62	11.86

*at full stroke

Basic Information

For general information see "About gas springs", 2.1
 Pressure medium Nitrogen
 Max. charging pressure 150 bar (at 20°C)
 Min. charging pressure 25 bar (at 20°C)
 Operating temperature 0 to +80°C
 Force increase by temperature..... ±0.3%/°C
 Recommended max strokes/min See chart
 Dampening length ≈ 30 mm
 Dampening speed 0.4 m/s
 Rod surface Nitrided
 Tube surface Black oxide
 Repair kit 3021494

Mounting Possibilities

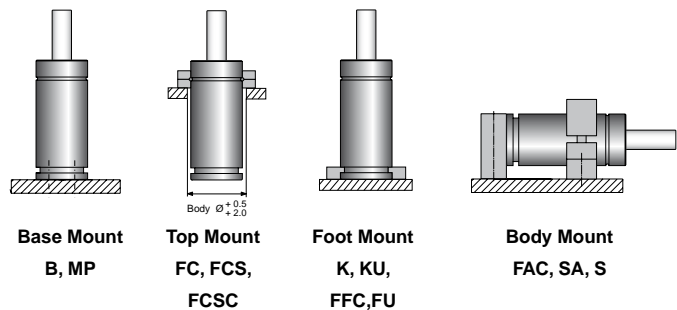

Note! For dimensions on mounting possibilities K-3000, KU-3000, FU-3000, FAC-3000, SA-3000 and FCSC-3000 refer to Chapter 3.

MP

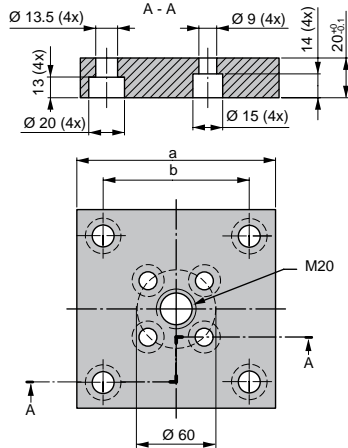

Note! Comes complete with screws to mount gas spring.

Order No.	a	b
MP-3000	120	92

FC

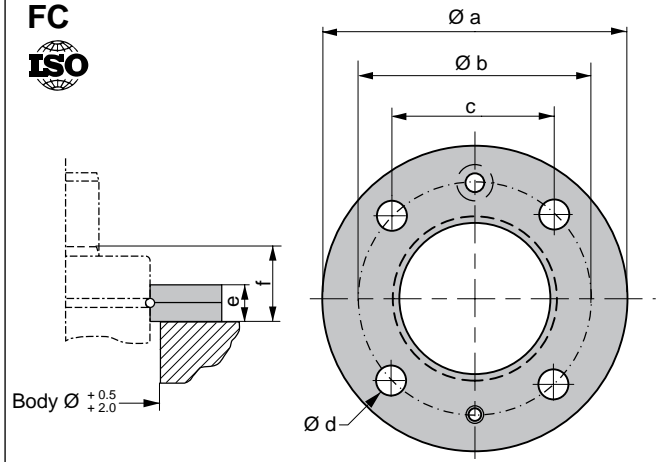

Order No.	Ø a	Ø b	c	Ø d	e	f
FC-3000	150	130	92	13.5	18	33

6

FCS

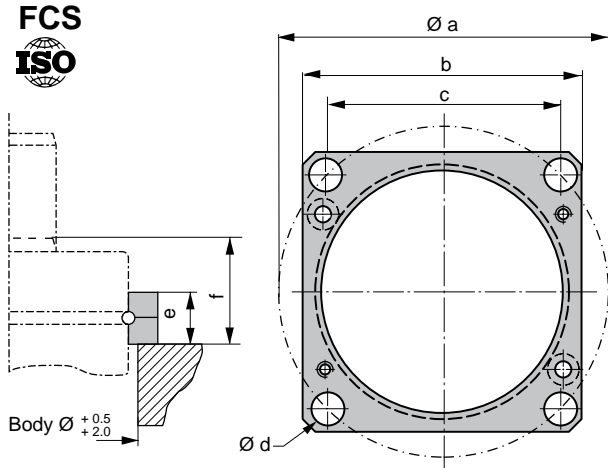

Order No.	Ø a	b	c	Ø d	e	f
FCS-3000	130	110	92	13.5	18	33

FFC

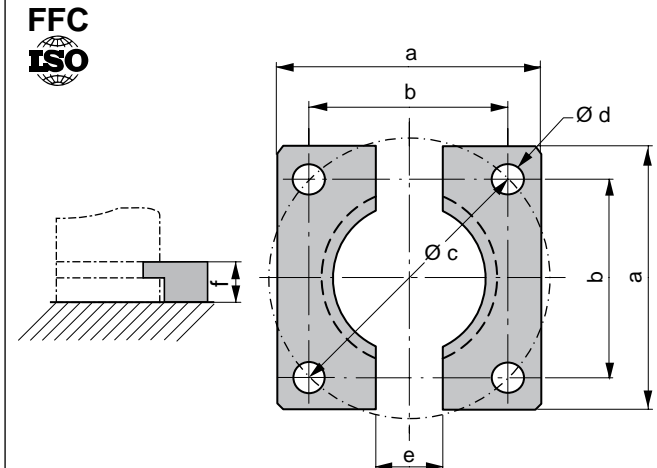

Order No.	a	b	Ø c	Ø d	e	f
FFC-3000	120	92	130	13.5	24	12

S

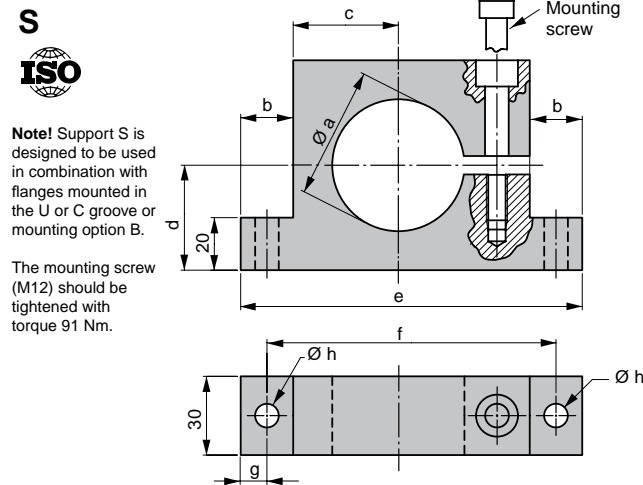

Note! Support S is designed to be used in combination with flanges mounted in the U or C groove or mounting option B.

The mounting screw (M12) should be tightened with torque 91 Nm.







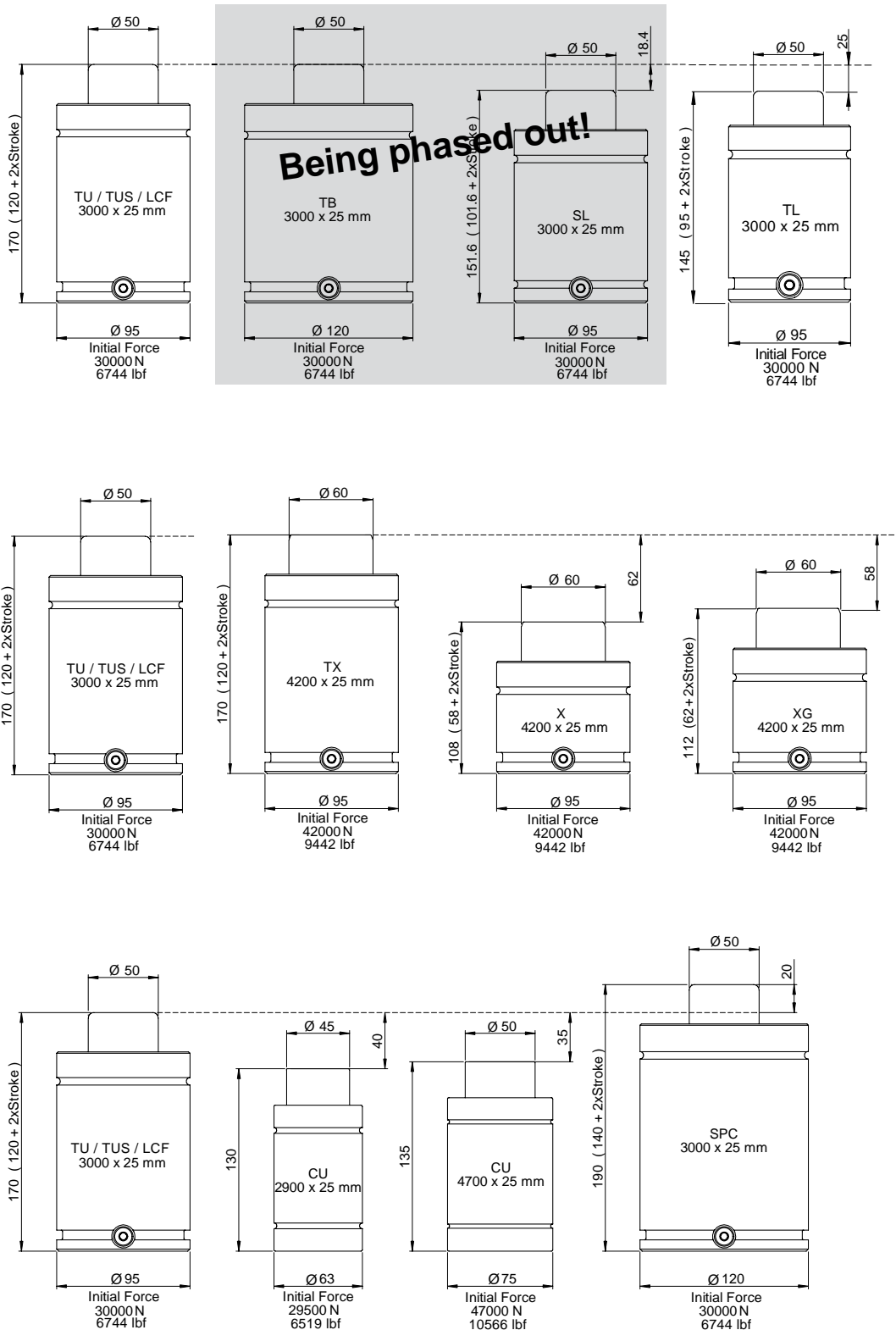





Order No.	Ø a	b	c	d	e	f	g	Ø h
S-3000	95.4	25	67.5	62.5	195	170	1.5	13

Note! For dimension on mounting possibilities K-1500, KU-1500, FU-1500, FAC-1500, SA-1500 and FCSC-1500 refer to Chapter 3.

Overview - $25000 \leq F_{INIT} < 50000$



25000 ≤ F_{INIT} < 50000

CU 2900		Page 2.7/2
CU 4700		Page 2.7/4
X 4200		Page 2.7/6
XG 4200		Page 2.7/8
TX 4200		Page 2.7/10
TL 3000		Page 2.7/12
TU 3000	 	Page 2.7/14
TUS 3000		Page 2.7/16
LCF 3000		Page 2.7/18
TB 3000	<i>Being phased out!</i> 	Page 2.7/20
SL 3000	<i>Being phased out!</i> 	Page 2.7/22
SPC 3000		Page 2.7/24

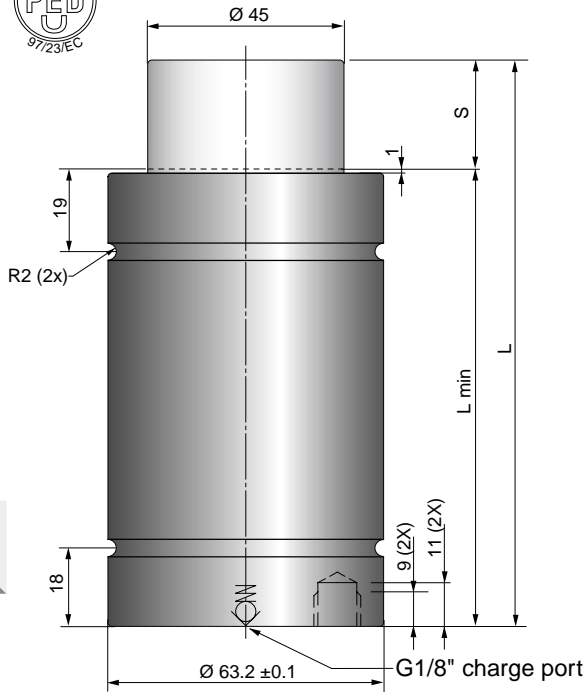

The CU gas spring is a very compact Bore Sealed gas spring, that gives a high force in a limited space.

Springs with stroke lengths over 25 mm should always be attached to the tool, using a flange or the tapped holes in the bottom of the spring. We also recommend shorter stroke springs to be fastened for optimal service-life.

As an option, this CU spring can be delivered with a Side-Port plate (SP) for applications where a side-port is needed (i.e. for use in hose systems).

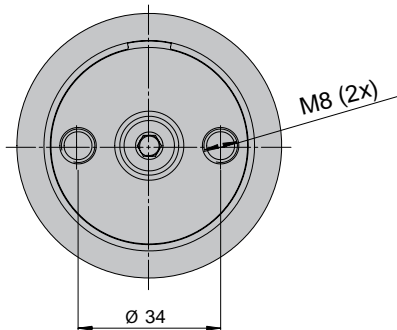

Volvo Part No.	Order No.	S Stroke	Force in N at 150 bar/+20°C		L ±0.25	L min	Gas vol. (l)	Weight (kg)
			Initial	End force**				
3054669	CU 2900-010	10	29500	38500	85	75	0.08	1.14
3054670	CU 2900-016	16		41000	103	87	0.12	1.28
3054671	CU 2900-025	25		43000	130	105	0.16	1.49
3054672	CU 2900-032	32*		44200	150	118	0.20	1.64
3054673	CU 2900-040	40*		45200	175	135	0.24	1.83
3054674	CU 2900-050	50*		45800	205	155	0.29	2.06

* = Should always be attached to the tool using the tapped holes in the bottom or a flange

** = at full stroke

Basic Information

For general information see "About gas springs", 2.1
 Pressure medium Nitrogen
 Max. charging pressure 150 bar (at 20° C)
 Min. charging pressure 25 bar (at 20° C)
 Operating temperature 0 to +80°C
 Force increase by temperature ±0.3%/°C
 Recommended max strokes/min ... ~ 80-100 (at 20°C)
 Max piston rod velocity 0.5 m/s

Rod surface..... Nitrided
 Tube surface Nitrided
 Repair kit 2014493

Repair kit. Volvo Part No.....3054848

Mounting Possibilities

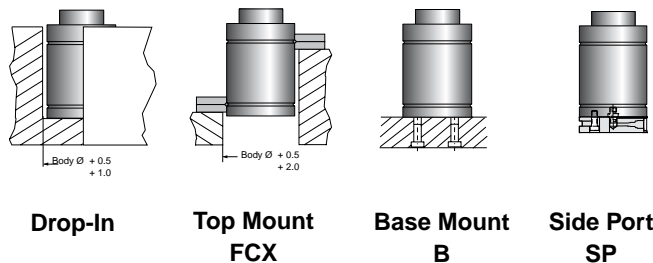

FCX

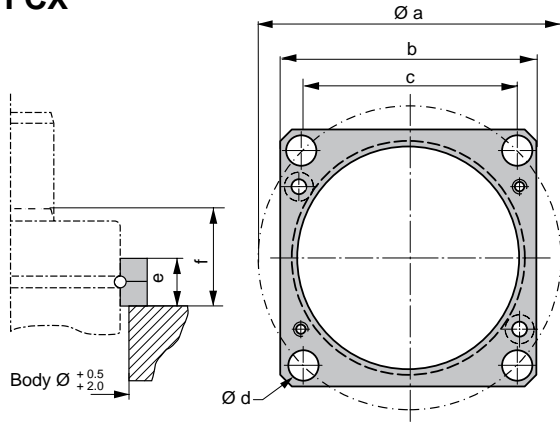

Volvo Part No.	Order No.	$\varnothing a$	b	c	$\varnothing d$	e	f
3044859	FCX-1500	104	90	73.5	11	16	27

SP 2900

It is also possible to order Side Port kit for attachment to old springs.

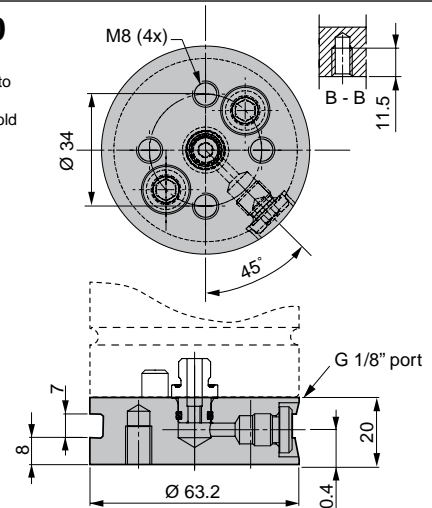

For model	Order No.	For U-groove mounts on SP
CU 2900	SP-2900	Refer to X 1500

CU 4700

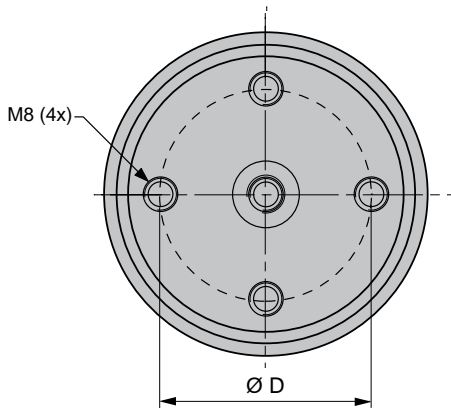
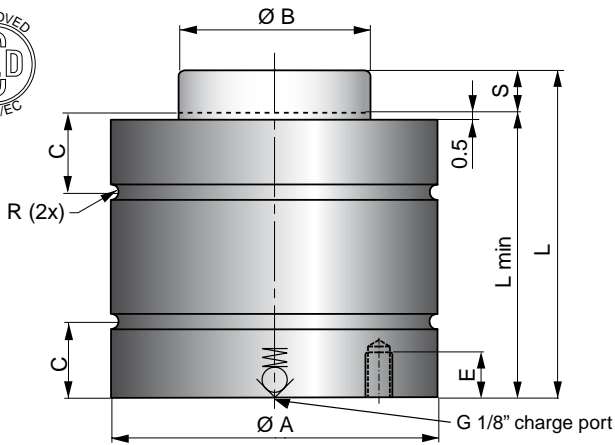

The CU gas spring is a very compact Bore Sealed gas spring, that gives a high force in a limited space. The max. frequency for the spring is 100 strokes/minute.

Springs with stroke lengths over 25 mm should always be attached to the tool, using a flange or the tapped holes in the bottom of the spring. We also recommend shorter stroke springs to be fastened for optimal service-life.

As an option, the CU springs can be delivered with a Side-Port plate (SP) for applications where a side-port is needed (i.e. for use in hose systems).

7

Volvo Part No.	Order No.	S Stroke	Force in N at 150 bar/+20°C		L ±0.25	L min	Ø A ±0.1	Ø B	C	Ø D	E	R	Gas vol. (l)	Weight (kg)
			Initial	End force**										
3051116	CU 4700-010	10	47000	67000	80	70	75.2	50	18	40	9	1.5	0.10	1.55
3051117	CU 4700-016	16		66000	106	90							0.17	1.79
3051118	CU 4700-025	25		68000	135	110							0.24	2.05
3054645	CU 4700-032	32*		67000	167	135							0.32	2.34
3054646	CU 4700-040	40*		67000	200	160							0.41	2.65
3054647	CU 4700-050	50*		67000	240	190							0.52	3.01

* = Should always be attached to the tool using the tapped holes in the bottom or a flange

** = at full stroke

Basic Information

For general information see "About gas springs", 2.1
 Pressure medium..... Nitrogen
 Max. charging pressure..... 150 bar (at 20°C)
 Min. charging pressure..... 25 bar (at 20°C)
 Operating temperature 0 to +80°C
 Force increase by temperature ±0.3%/°C
 Recommended max strokes/min ~80 to 100 (at 20° C)
 Max piston rod velocity 0.5 m/s

Rod surface..... Nitrided
 Tube surface Nitrided
 Repair kit 2014493

Repair kit. Volvo Part No.....3044232

Mounting Possibilities

Drop-In

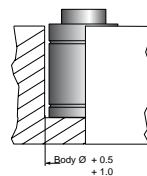

Top Mount FK

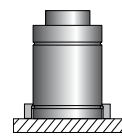
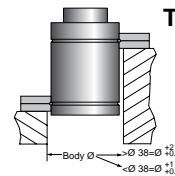

Foot Mount BFP

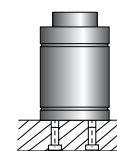

Base Mount B



Side Port SP

FK

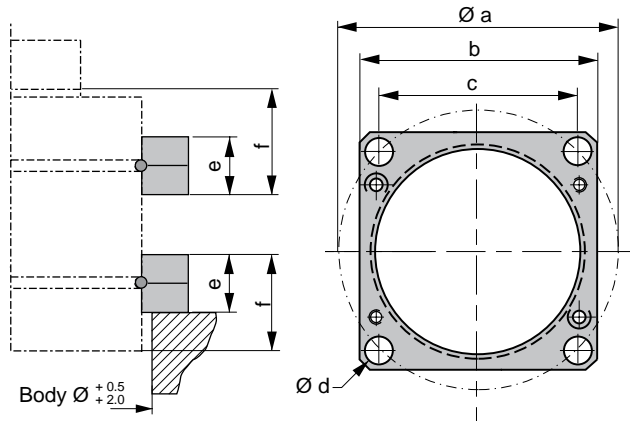

Volvo Part No.	For model	Order No.	$\varnothing a$	$\varnothing b$	c	$\varnothing d$	e	f
3051122	CU 4700	FK-1500	104	90	73.5	11	16	26

Note! For spring of earlier version with R=2.5 FCS 1500 respective FCS 3000 should be used.
Please contact your local distributor for more information.

BFP

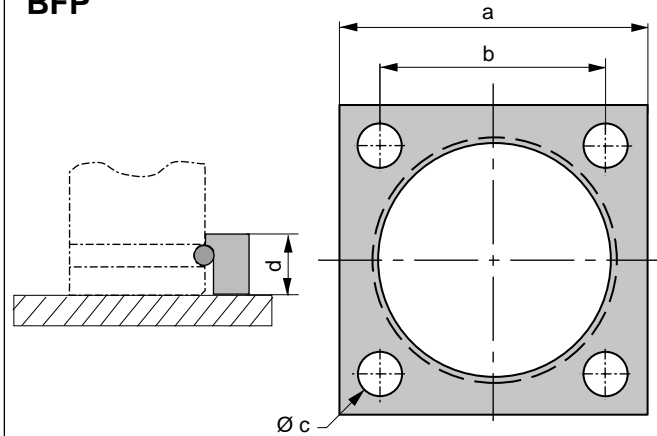

For model	Order No.	a	b	$\varnothing c$	d
CU 4700	BFP-4700	90	73.5	11	24.5

Note! BF flange for earlier version with R=2.5 is obsolete.
Please contact your local distributor for more information.

SP 4700

It is also possible to order Side Port kit for attachment to old springs.

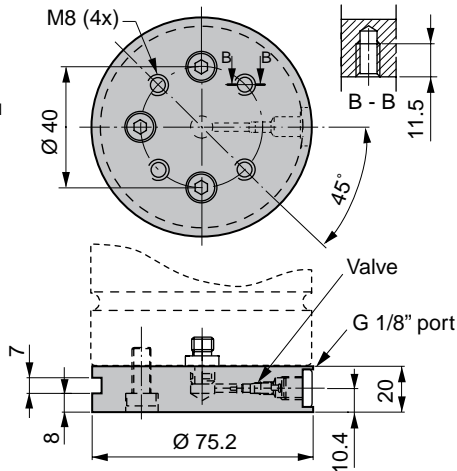

For model	Order No.	For U-groove mounts on SP
CU 4700	SP-4700	Refer to TU 1500

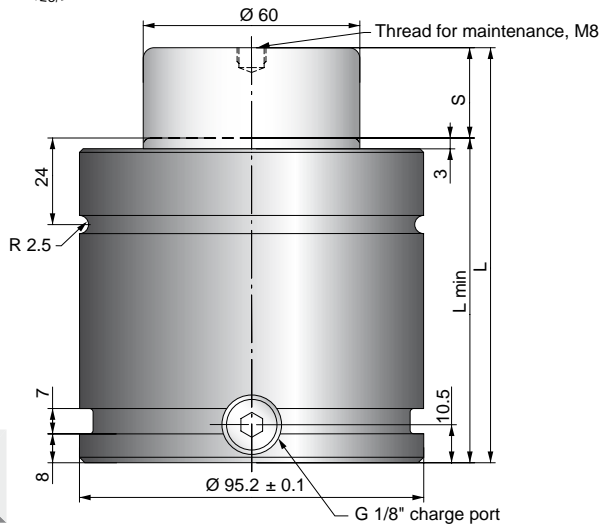

The Power Line series are our shortest and most powerful Piston Rod Sealed gas springs, giving you a great deal of force in a very small amount of space.

These gas springs are available with forces from 1700 N up to 200000 N and stroke lengths between 7 and 125 mm.

There is a side port for gas charging that can also be used to connect to a hose system.

An upper C-groove, lower U-groove together with four M8 threaded holes allow various mounting possibilities using our standard mounts.

7

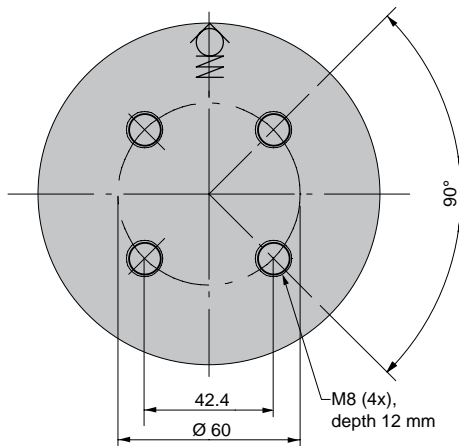

Volvo Part No.	Order No.	S Stroke	Force in N at 150 bar/+20°C		L ±0.25	L min	Gas vol. (l)	Weight (kg)
			Initial	End force*				
	X 4200-016	16	42000	61700	90	74	0.15	2.60
3050778	X 4200-019	19		63700	96	77	0.18	2.70
3050779	X 4200-025	25		60800	108	83	0.26	2.90
3050780	X 4200-032	32		64300	122	90	0.30	3.05
3050781	X 4200-038	38		65800	134	96	0.32	3.20
3050782	X 4200-050	50		67000	158	108	0.40	3.50
3050783	X 4200-063	63		67800	184	121	0.49	3.80
3050784	X 4200-075	75		68000	208	133	0.58	4.20
3050785	X 4200-080	80		68600	218	138	0.61	4.40
3050786	X 4200-100	100		69100	258	158	0.74	4.90
3050787	X 4200-125	125		69600	308	183	0.91	5.40

* = at full stroke

Basic Information

- For general information see "About gas springs", 2.1
- Pressure medium Nitrogen
- Max. charging pressure 150 bar (at 20°C)
- Min. charging pressure 25 bar (at 20°C)
- Operating temperature 0 to +80°C
- Force increase by temperature ±0.3%/°C
- Recommended max strokes/min ... ~ 30 to 100 (at 20°C)
- Max piston rod velocity 1.6 m/s
- Rod surface Nitrided
- Tube surface Black oxide
- Repair kit 3018849

Repair kit. Volvo Part No.....3050730

Mounting Possibilities

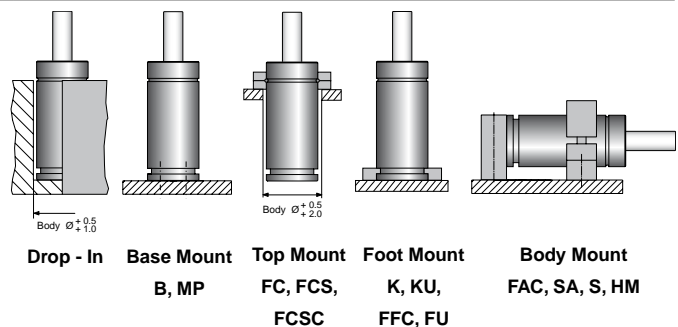

Note! For dimensions on mounting possibilities K-3000, KU-3000, FU-3000, FAC-3000, SA-3000, HM-3000 and FCSC-3000 refer to Chapter 3.

MP
ISO

Note! Comes complete with screws to mount gas spring.

Order No.	a	b
MP-3000	120	92

FC
ISO

Order No.	Ø a	Ø b	c	Ø d	e	f
FC-3000	150	130	92	13.5	18	33

FCS
ISO

Volvo Part No.	Order No.	Ø a	b	c	Ø d	e	f
3044017	FCS-3000	130	110	92	13.5	18	33

FFC
ISO

Volvo Part No.	Order No.	a	b	Ø c	Ø d	e	f
3054002	FFC-3000	120	92	130	13.5	24	12

S
ISO

Note! Support S is designed to be used in combination with flanges mounted in the U or C groove or attachment B.

The mounting screw (M12) should be tightened with torque 91 Nm.

Volvo part No.	Order No.	Ø a	b	c	d	e	f	g	Ø h
3044223	S-3000	95.4	25	67.5	62.5	195	170	12.5	13

Note! For dimensions on mounting possibilities K-3000, KU-3000, FU-3000, FAC-3000, SA-3000, HM-3000 and FCSC-3000 refer to Chapter 3.

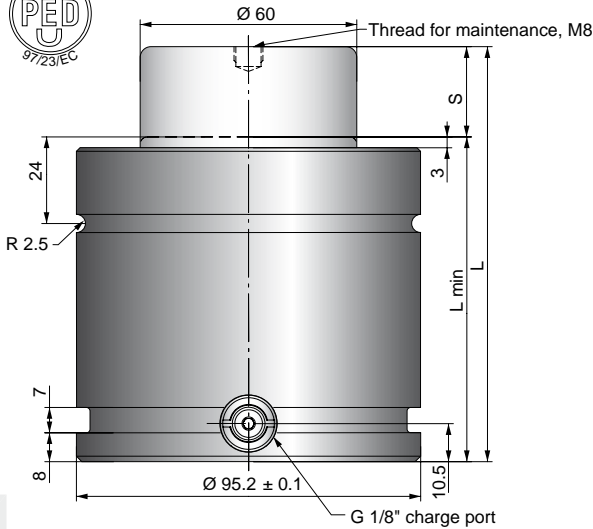

The Power Line series are our shortest and most powerful Piston Rod Sealed gas springs, giving you a great deal of force in a very small amount of space.

These gas springs are available with forces from 3500 N up to 66000 N and stroke lengths between 10 and 125 mm.

There is a side and bottom port for gas charging that can also be used to connect to a hose system.

An upper C-groove, lower U-groove together with four M8 threaded holes allow various mounting possibilities using our standard mounts.

7

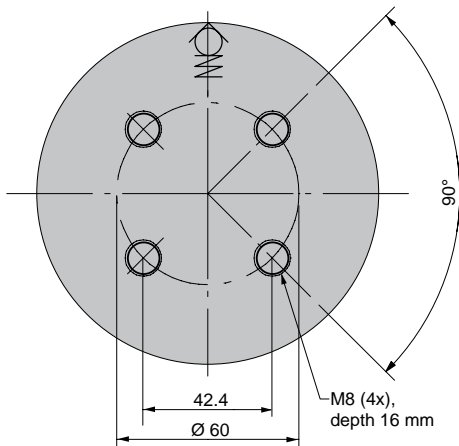

Order No.	S Stroke	Force in N at 150 bar/+20°C		L ±0.25	L min	Gas vol. (l)	Weight (kg)
		Initial	End force*				
XG 4200-016	16	42000	61700	94	78	0.15	2.81
XG 4200-019	19		63700	100	81	0.18	2.88
XG 4200-025	25		60800	112	87	0.26	2.96
XG 4200-032	32		64300	126	94	0.30	3.13
XG 4200-038	38		65800	138	100	0.32	3.28
XG 4200-050	50		67000	162	112	0.40	3.57
XG 4200-063	63		67800	188	125	0.49	4.10
XG 4200-075	75		68000	212	137	0.58	4.20
XG 4200-080	80		68600	222	142	0.61	4.32
XG 4200-100	100		69100	262	162	0.74	4.81
XG 4200-125	125		69600	312	187	0.91	5.42

* = at full stroke

Basic Information

- For general information see "About gas springs", 2.1
- Pressure medium Nitrogen
- Max. charging pressure 150 bar (at 20°C)
- Min. charging pressure 25 bar (at 20°C)
- Operating temperature 0 to +80°C
- Force increase by temperature ±0.3%/°C
- Recommended max strokes/min ... ~ 30 to 100 (at 20°C)
- Max piston rod velocity 1.6 m/s
- Rod surface Nitrided
- Tube surface Black oxide
- Repair kit 3018849

Mounting Possibilities

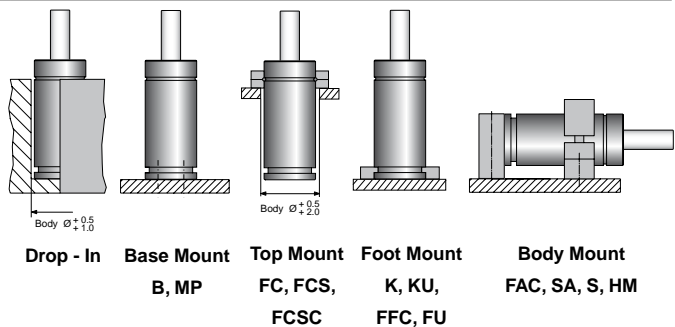

Note! For dimensions on mounting possibilities K-3000, KU-3000, FU-3000, FAC-3000, SA-3000, HM-3000 and FCSC-3000 refer to Chapter 3.

MP
ISO

Note! Comes complete with screws to mount gas spring.

Order No.	a	b
MP-3000	120	92

FC
ISO

Order No.	Ø a	Ø b	c	Ø d	e	f
FC-3000	150	130	92	13.5	18	33

FCS
ISO

Order No.	Ø a	b	c	Ø d	e	f
FCS-3000	130	110	92	13.5	18	33

FFC
ISO

Order No.	a	b	Ø c	Ø d	e	f
FFC-3000	120	92	130	13.5	24	12

S
ISO

Note! Support S is designed to be used in combination with flanges mounted in the U or C groove or attachment B.

The mounting screw (M12) should be tightened with torque 91 Nm.

Order No.	Ø a	b	c	d	e	f	g	Ø h
S-3000	95.4	25	67.5	62.5	195	170	12.5	13

Note! For dimensions on mounting possibilities K-3000, KU-3000, FU-3000, FAC-3000, SA-3000, HM-3000 and FCSC-3000 refer to Chapter 3.

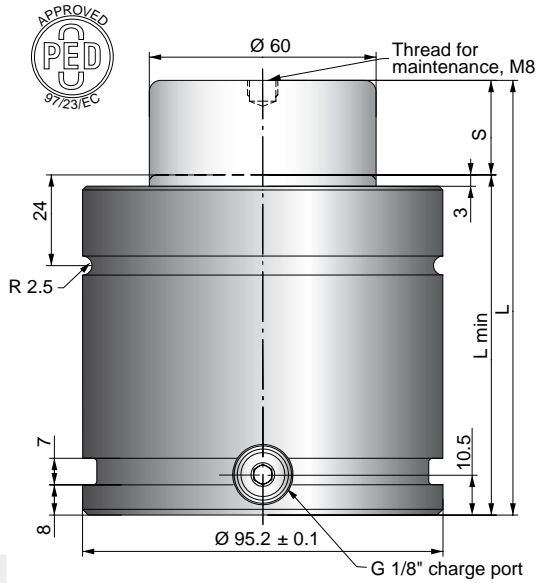

The Power Line - Heavy Duty series is a crossover between the standard TU series and Power Line X series.

These gas springs are available with forces from 9200 N up to 95000 N and stroke lengths between 13 and 300 mm.

There is an optional bottom port for hose/base plate connection.

An upper C-groove, lower U-groove and bottom threaded holes allow various mounting possibilities using our standard mounts.

Optional bottom port for hose/ base plate connection

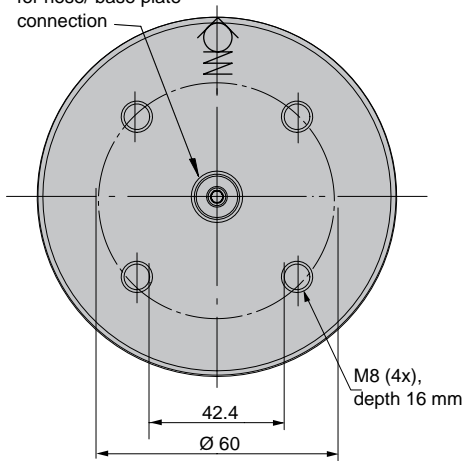

Volvo Part No.	Order No.	S Stroke	Force in N at 150 bar/+20°C		L ±0.25	L min	Gas vol. (l)	Weight (kg)
			Initial	End force*				
3054700	TX 4200-025	25	42000	52122	170	145	0.43	5.08
3054701	TX4200-038	38		55108	196	158	0.52	5.41
3054702	TX 4200-050	50		57207	220	170	0.60	5.71
3054703	TX 4200-063	63		58999	246	183	0.68	6.05
	TX 4200-075	75		60336	270	195	0.76	6.35
3054704	TX 4200-080	80		60822	280	200	0.80	6.48
3054705	TX 4200-100	100		62455	320	220	0.93	6.99
3054706	TX 4200-125	125		63985	370	245	1.10	7.63
	TX 4200-150	150		65142	420	270	1.27	8.27
3054707	TX 4200-160	160		65529	440	280	1.33	8.53
	TX 4200-175	175		66047	470	295	1.43	8.91
	TX 4200-200	200		66775	520	320	1.60	9.55
3054708	TX 4200-250	250		67873	620	370	1.93	11.08
	TX 4200-300	300		68661	720	420	2.27	12.11

* = at full stroke

Basic Information

For general information see "About gas springs", 2.1
 Pressure medium Nitrogen
 Max. charging pressure 150 bar (at 20°C)
 Min. charging pressure 25 bar (at 20°C)
 Operating temperature 0 to +80°C
 Force increase by temperature ±0.3%/°C
 Recommended max strokes/min ... ~ 40 to 100 (at 20°C)
 Max piston rod velocity 1.6 m/s

Rod surface Nitrided
 Tube surface Black oxide
 Repair kit 3022953

Repair kit. Volvo Part No.....3054850

Mounting Possibilities

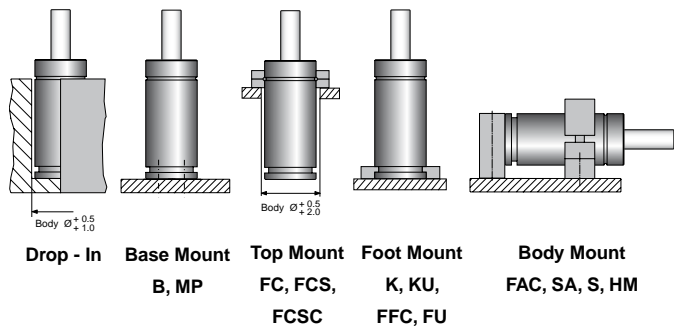

Note! For dimensions on mounting possibilities K-3000, KU-3000, FU-3000, FAC-3000, SA-3000, HM-3000 and FCSC-3000 refer to Chapter 3.

MP
ISO

Note! Comes complete with screws to mount gas spring.

Order No.	a	b
MP-3000	120	92

FC
ISO

Order No.	Ø a	Ø b	c	Ø d	e	f
FC-3000	150	130	92	13.5	18	33

FCS
ISO

Volvo Part No.	Order No.	Ø a	b	c	Ø d	e	f
3044017	FCS-3000	130	110	92	13.5	18	33

FFC
ISO

Volvo Part No.	Order No.	a	b	Ø c	Ø d	e	f
3054002	FFC-3000	120	92	130	13.5	24	12

S
ISO

Note! Support S is designed to be used in combination with flanges mounted in the U or C groove or attachment B.

The mounting screw (M12) should be tightened with torque 91 Nm.

Volvo part No.	Order No.	Ø a	b	c	d	e	f	g	Ø h
3044223	S-3000	95.4	25	67.5	62.5	195	170	12.5	13

Note! For dimensions on mounting possibilities K-3000, KU-3000, FU-3000, FAC-3000, SA-3000, HM-3000 and FCSC-3000 refer to Chapter 3.

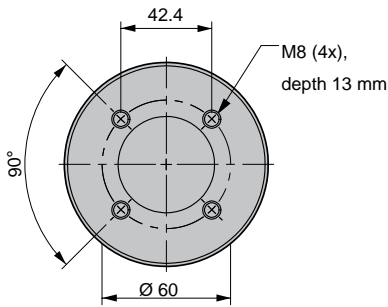
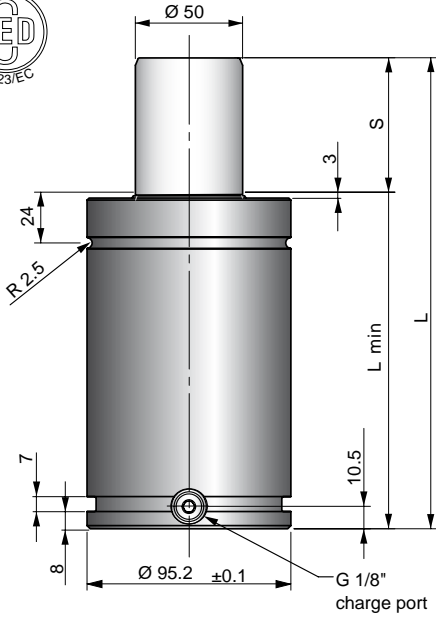

The TL series ranges from model sizes 750 to 5000, with the same features and technology as the TU series.

At the same time, the TL gas spring is shorter than the corresponding TU gas spring by 25 mm, except TL 5000 which is 37.5 mm shorter. TL springs share the same TU mounting possibilities and stroke lengths, with exception of strokes 12.5, 37.5 and 62.5.

Order No.	S Stroke	Force in N at 150 bar/+20°C		L ±0.25	L min	Gas vol. (l)	Weight (kg)
		Initial	End force*				
TL 3000-013	12.5	29452	38745	120	107.5	0.14	4.84
TL 3000-025	25		41826	145	120	0.21	5.24
TL 3000-038	37.5		43477	170	132.5	0.27	5.64
TL 3000-050	50		44382	195	145	0.33	1.2
TL 3000-063	62.5		45068	220	157.5	0.40	6.43
TL 3000-075	75		45486	245	170	0.46	6.83
TL 3000-080	80		45635	255	175	0.48	6.99
TL 3000-088	87.5		45832	270	182.5	0.52	7.23
TL 3000-100	100		46101	295	195	0.58	7.62
TL 3000-113	112.5		46317	320	207.5	0.65	8.02
TL 3000-125	125		46494	345	220	0.71	1.2
TL 3000-138	137.5		46641	370	232.5	0.77	1.20
TL 3000-150	150		46766	395	245	0.84	9.21
TL 3000-160	160		46853	415	255	0.89	9.53
TL 3000-175	175		46966	445	270	0.96	10
TL 3000-200	200		47118	495	295	1.09	10.79
TL 3000-225	225	47239	545	320	1.21	1.20	
TL 3000-250	250	47337	595	345	1.34	12.38	

* = at full stroke

Basic Information

- For general information see "About gas springs", 2.1
- Pressure medium Nitrogen
- Max. charging pressure 150 bar
- Min. charging pressure..... 25 bar
- Operating temperature 0 to +80°C
- Force increase by temperature ±0.3%/°C
- Recommended max strokes/min ~ 15-40 (at 20°C)
- Max piston rod velocity 1.6 m/s
- Rod surface..... Nitrided
- Tube surface Black oxide
- Repair kit..... 3024171

Mounting Possibilities

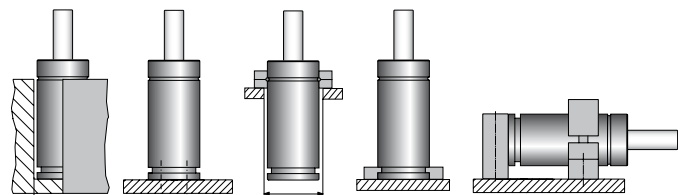

- Drop - In
- Base Mount B, MP
- Top Mount FC, FCS, FCSC
- Foot Mount K, KU, FFC, FU
- Body Mount FAC, SA, S, HM

Note! For dimensions on mounting possibilities K-3000, KU-3000, FU-3000, FAC-3000, SA-3000, HM-3000 and FCSC-3000 refer to Chapter 3.

MP
ISO

Note! Comes complete with screws to mount gas spring.

Order No.	a	b
MP-3000	120	92

FC
ISO

Order No.	Ø a	Ø b	c	Ø d	e	f
FC-3000	150	130	92	13.5	18	33

FCS
ISO

Order No.	Ø a	b	c	Ø d	e	f
FCS-3000	130	110	92	13.5	18	33

FFC
ISO

Order No.	a	b	Ø c	Ø d	e	f
FFC-3000	120	92	130	13.5	24	12

S
ISO

Note! Support S is designed to be used in combination with flanges mounted in the U or C groove or mounting option B.

The mounting screw (M12) should be tightened with torque 91 Nm.

Order No.	Ø a	b	c	d	e	f	g	Ø h
S-3000	95.4	25	67.5	62.5	195	170	12.5	13

Note! For dimensions on mounting possibilities K-3000, KU-3000, FU-3000, FAC-3000, SA-3000, HM-3000 and FCSC-3000 refer to Chapter 3.

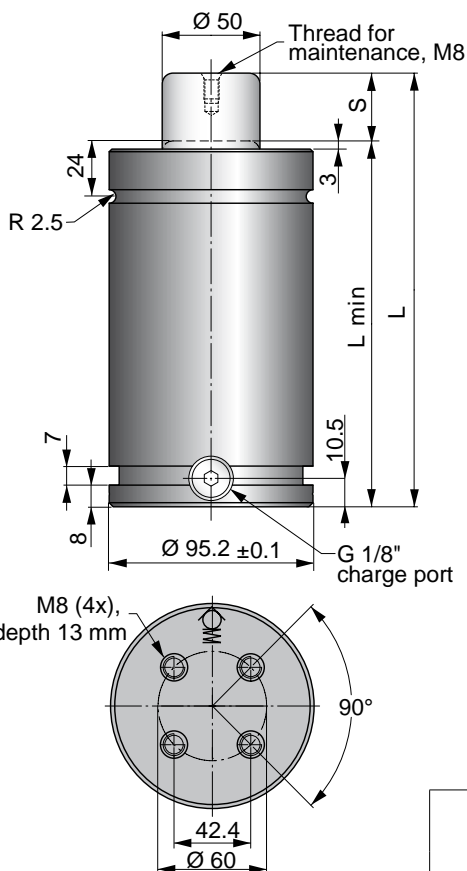

The standard line of gas springs is the TU line. Sizes 250 to 10000 correspond to the ISO 11901 standard for gas springs.

Sizes 750 to 7500 correspond to FORD's, GM's and Renault's automotive gas spring standards. When ordering a Renault standard gas spring add an R to the Order No. (for example: TUR 3000-xxx).

TUR will be replaced by TUS.

Being phased out!

TU, TUR och LCF 3000 gas springs are also available with double charging ports. When ordering this type, add a D to the Order No.

For example:
TUD 3000-xxx

TUD 3000 example

Note! TUD, TURD and LCFD 3000 gas springs have two valves and are delivered charged.

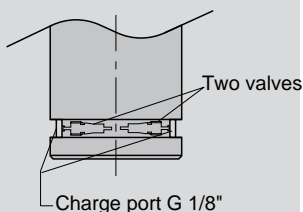

TUR will be replaced by TUS

Volvo Part No.	Order No.	S Stroke	Force in N at 150 bar/+20°C		L ±0.25	L min	Gas vol. (l)	Weight (kg)	ISO
			Initial	End force*					
9975966	TU 3000-025	25	30000	42000	170	145	0.20	6.45	✓
3044189	TU 3000-038	38.1		43000	196.2	158.1	0.26	6.87	
9975967	TU 3000-050	50		44000	220	170	0.32	7.25	✓
3044190	TU 3000-064	63.5		45000	247	183.5	0.38	7.67	
9975968	TU 3000-080	80		46000	280	200	0.46	8.20	✓
9975969	TU 3000-100	100		47000	320	220	0.56	8.83	✓
9975970	TU 3000-125	125		47000	370	245	0.69	9.63	✓
9975971	TU 3000-160	160		47000	440	280	0.87	10.74	✓
	TU 3000-200	200		48000	520	320	1.07	12.00	
	TU 3000-250	250		48000	620	370	1.32	13.59	
	TU 3000-300	300	48000	720	420	1.57	15.18		

* = at full stroke

Basic Information

Mounting Possibilities

- For general information see "About gas springs", 2.1
- Pressure medium Nitrogen
- Max. charging pressure 150 bar
- Min. charging pressure 25 bar
- Operating temperature 0 to +80°C
- Force increase by temperature ±0.3%/°C
- Recommended max strokes/min ~ 15-40 (at 20°C)
- Max piston rod velocity 1.6 m/s
- Rod surface Nitrided
- Tube surface Black oxide
- Repair kits
- * TU 3000 new version 3019025
- Repair kit. Volvo Part No. 3050720
- TU 3000 old version 2014068-03
- Repair kit. Volvo Part No. 3040925
- *New version is identified by circular rings on the top of tube, guide and rod.

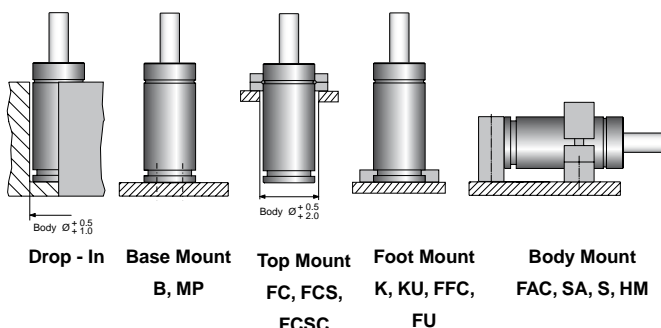

Note! For dimensions on mounting possibilities K-3000, KU-3000, FU-3000, FAC-3000, SA-3000, HM-3000 and FCSC-3000 refer to Chapter 3.

MP
ISO

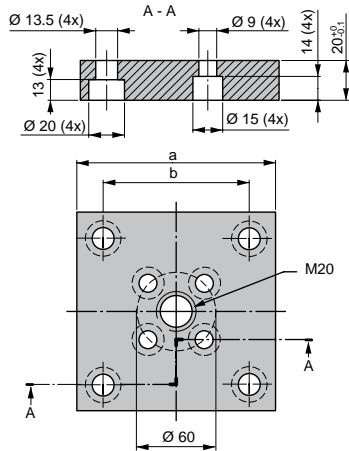

Note!
Comes complete
with screws to
mount gas spring.

Order No.	a	b
MP-3000	120	92

FC
ISO

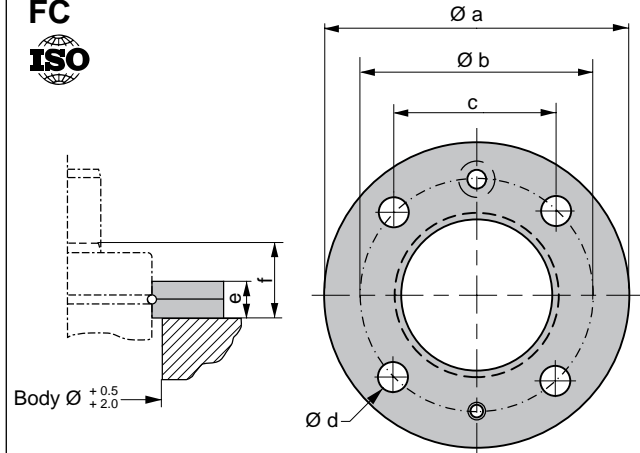

Order No.	Ø a	Ø b	c	Ø d	e	f
FC-3000	150	130	92	13.5	18	33

FCS
ISO

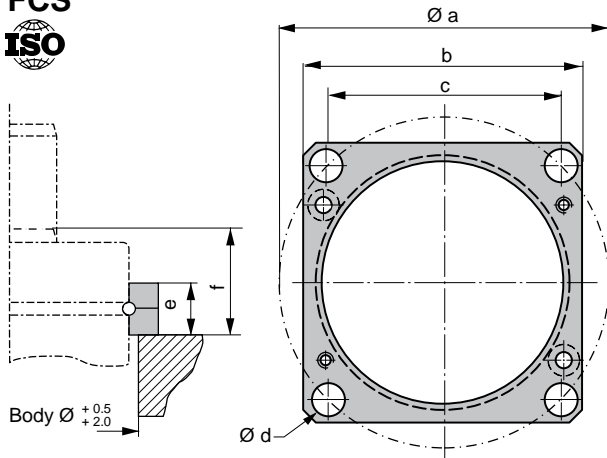

Volvo Part No.	Order No.	Ø a	b	c	Ø d	e	f
3044017	FCS-3000	130	110	92	13.5	18	33

FFC
ISO

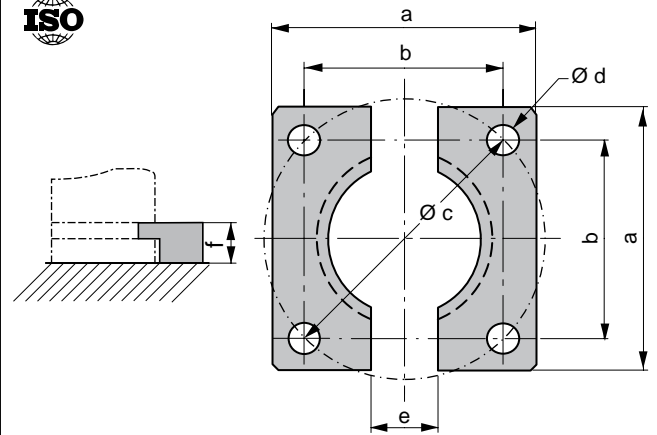

Volvo Part No.	Order No.	a	b	Ø c	Ø d	e	f
3054002	FFC-3000	120	92	130	13.5	24	12

S
ISO

Note! Support S is
designed to be used
in combination with
flanges mounted in
the U or C groove or
mounting option B.

The mounting screw
(M12) should be
tightened with
torque 91 Nm.

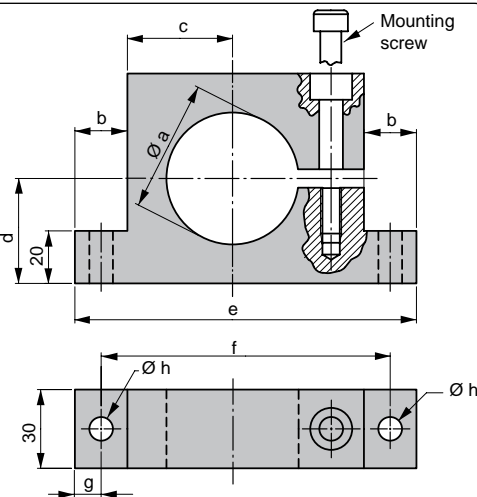

Volvo Part No.	Order No.	Ø a	b	c	d	e	f	g	Ø h
3044223	S-3000	95.4	25	67.5	62.5	195	170	12.5	13

Note! For dimensions on mounting possibilities K-3000, KU-3000, FU-3000, FAC-3000, SA-3000, HM-3000 and FCSC-3000 refer to Chapter 3.

TUS 3000

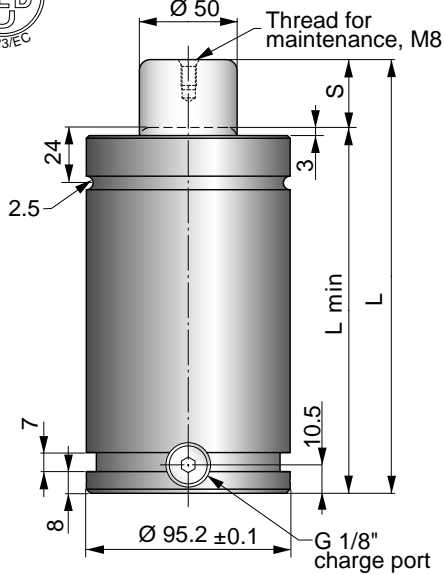

The High Speed gas springs (TUS) are engineered to withstand press stroke speeds to a maximum 2 m/s, which meet the safety demands from the French automotive manufacturer Renault.

These gas springs are available in sizes 750 to 7500 and dimensions correspond to the ISO 11901 standard for gas springs.

TUS gas spring will replace TUR that is being phased out.

7

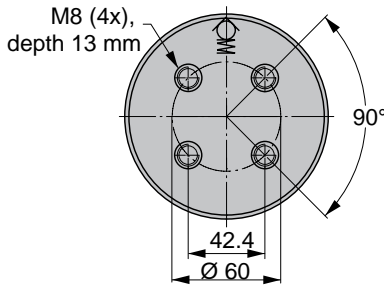

Order No.	S Stroke	Force in N at 150 bar/+20°C		L ±0.25	L min	Gas vol. (l)	Weight (kg)
		Initial	End force*				
TUS 3000-025	25	30000	42000	170	145	0.20	6.35
TUS 3000-038	38.1		43000	196.2	158.1	0.26	6.75
TUS 3000-050	50		44000	220	170	0.32	7.50
TUS 3000-064	63.5		45000	247	183.5	0.38	7.70
TUS 3000-080	80		46000	280	200	0.46	8.10
TUS 3000-100	100		47000	320	220	0.56	8.85
TUS 3000-125	125		47000	370	245	0.69	9.90
TUS 3000-160	160		47000	440	280	0.87	10.80
TUS 3000-200	200		48000	520	320	1.07	12.20
TUS 3000-250	250		48000	620	370	1.32	13.70
TUS 3000-300	300		48000	720	420	1.57	15.30

* = at full stroke

Basic Information

For general information see "About gas springs", 2.1
 Pressure medium Nitrogen
 Max. charging pressure 150 bar
 Min. charging pressure..... 25 bar
 Operating temperature 0 to +80°C
 Force increase by temperature ±0.3%/°C
 Recommended max strokes/min ~ 15-40 (at 20°C)
 Max piston rod velocity 2 m/s

Rod surface..... Nitrided
 Tube surface Black oxide
 Repair kit..... 3019279

Mounting Possibilities

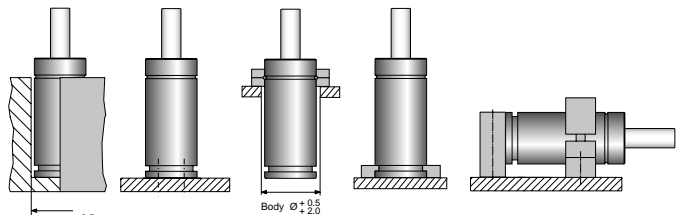

Drop - In **Base Mount** **Top Mount** **Body Mount**
 B, MP FC, FCS, FCSC K, KU, FFC, FU FAC, SA, S, HM

Note! For dimensions on mounting possibilities K-3000, KU-3000, FU-3000, FAC-3000, SA-3000, HM-3000 and FCSC-3000 refer to Chapter 3.

MP

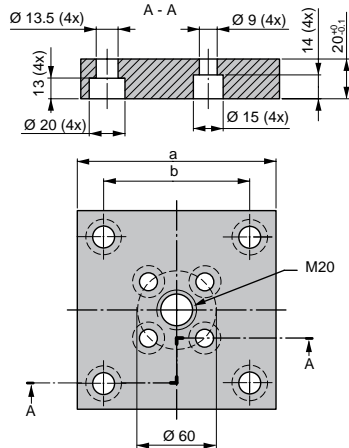

Note! Comes complete with screws to mount gas spring.

Order No.	a	b
MP-3000	120	92

FC

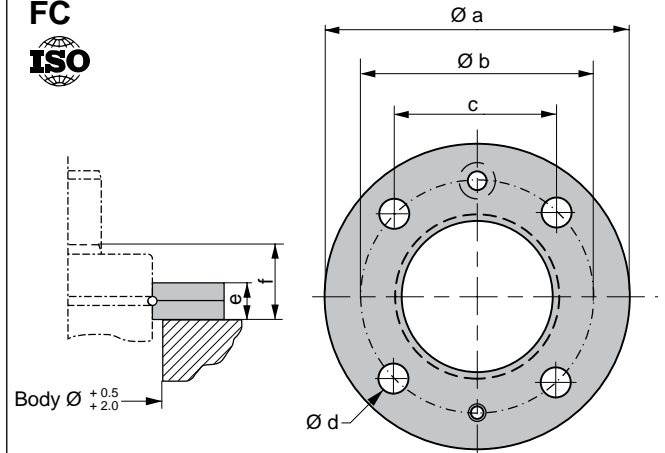

Order No.	Ø a	Ø b	c	Ø d	e	f
FC-3000	150	130	92	13.5	18	33

FCS

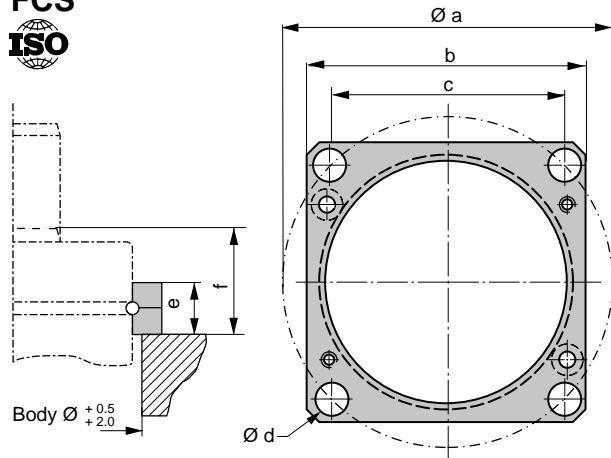

Order No.	Ø a	b	c	Ø d	e	f
FCS-3000	130	110	92	13.5	18	33

FFC

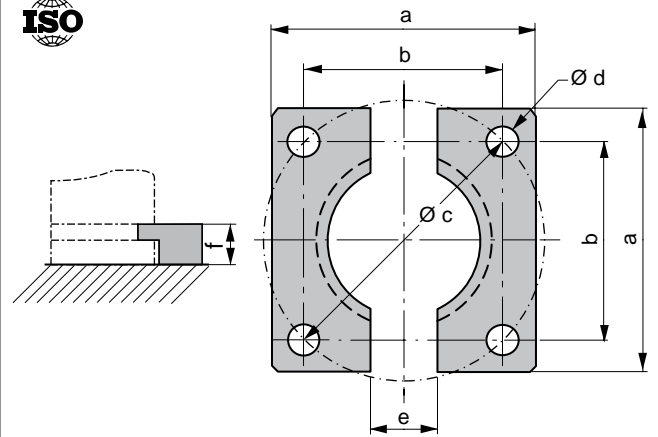

Order No.	a	b	Ø c	Ø d	e	f
FFC-3000	120	92	130	13.5	24	12

S



Note! Support S is designed to be used in combination with flanges mounted in the U or C groove or mounting option B.

The mounting screw (M12) should be tightened with torque 91 Nm.

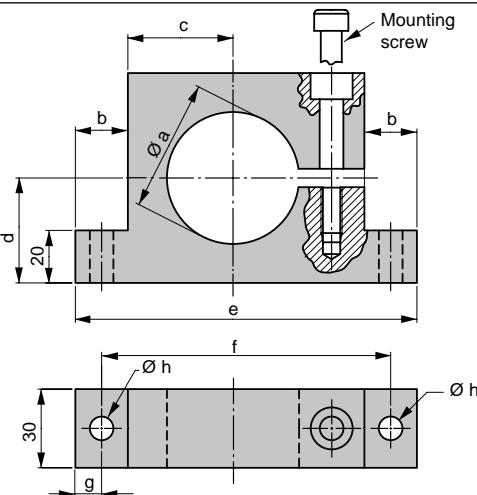

Order No.	Ø a	b	c	d	e	f	g	Ø h
S-3000	95.4	25	67.5	62.5	195	170	12.5	13

Note! For dimensions on mounting possibilities K-3000, KU-3000, FU-3000, FAC-3000, SA-3000, HM-3000 and FCSC-3000 refer to Chapter 3.

LCF 3000

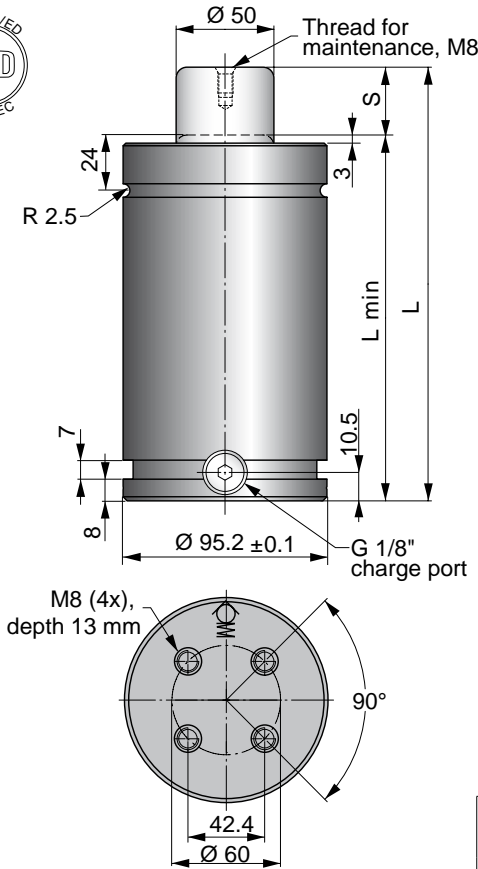

Low Contact Force (LCF) gas springs are designed to reduce excessive shock loads, high noise levels and extreme pad bounce, all factors that lead to high press maintenance costs and noise pollution.

Force vs Stroke for LCF 3000 Springs

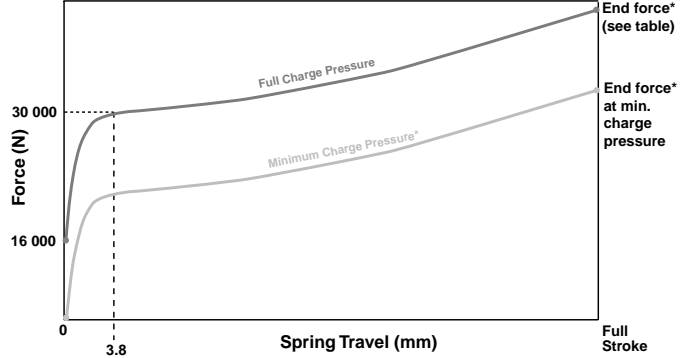

Being phased out!

TU, TUR och LCF 3000 gas springs are also available with double charging ports. When ordering this type, add a D to the Order No.

For example: LCFD 3000-xxx

Note! TUD, TURD and LCFD 3000 gas springs have two valves and are delivered charged.

LCFD 3000 example

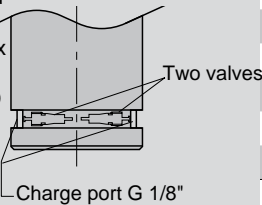

volvo Part No.	Order No.	S Stroke	Force in N at 150 bar/+20°C		L ±0.25	L min	Gas vol. (l)	Weight (kg)
			Initial	End force*				
	LCF 3000-025	25	30000	42000	170	145	0.20	6.35
	LCF 3000-038	38.1		43000	196.2	158.1	0.26	6.75
	LCF 3000-050	50		44000	220	170	0.32	7.50
	LCF 3000-064	63.5		45000	247	183.5	0.38	7.70
	LCF 3000-080	80		46000	280	200	0.46	8.10
	LCF 3000-100	100		47000	320	220	0.56	8.85
	LCF 3000-125	125		47000	370	245	0.69	9.90
	LCF 3000-160	160		47000	440	280	0.87	10.80
	LCF 3000-200	200		48000	520	320	1.07	12.20
	LCF 3000-250	250		48000	620	370	1.32	13.70
	LCF 3000-300	300	48000	720	420	1.57	15.30	

* = at full stroke

Basic Information

For general information see "About gas springs", 2.1
 Pressure medium Nitrogen
 Max. charging pressure 150 bar
 Min. charging pressure..... 70 bar
 Operating temperature 0 to +80°C
 Force increase by temperature ±0.3%/°C
 Recommended max strokes/min ~ 15-40 (at 20°C)
 Max piston rod velocity 1.6 m/s

Rod surface..... Nitrided
 Tube surface Black oxide
 Repair kits

* LCF 3000 new version..... 3019379
 LCF 3000 old version..... 3019132

*New version is identified by circular rings on the top of tube, guide and rod.

Mounting Possibilities

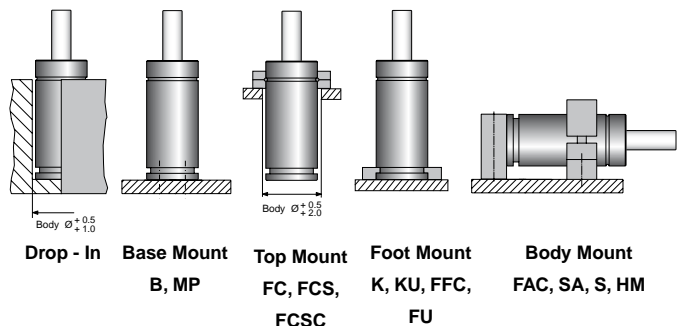

Drop - In **Base Mount** **Top Mount** **Foot Mount** **Body Mount**
 B, MP FC, FCS, FCSC K, KU, FFC, FU FAC, SA, S, HM

Note! For dimensions on mounting possibilities K-3000, KU-3000, FU-3000, FAC-3000, SA-3000, HM-3000 and FCSC-3000 refer to Chapter 3.

MP
ISO

Note! Comes complete with screws to mount gas spring.

Order No.	a	b
MP-3000	120	92

FC
ISO

Order No.	Ø a	Ø b	c	Ø d	e	f
FC-3000	150	130	92	13.5	18	33

FCS
ISO

Volvo Part No.	Order No.	Ø a	b	c	Ø d	e	f
3044017	FCS-3000	130	110	92	13.5	18	33

FFC
ISO

Volvo Part No.	Order No.	a	b	Ø c	Ø d	e	f
3054002	FFC-3000	120	92	130	13.5	24	12

S
ISO

Note! Support S is designed to be used in combination with flanges mounted in the U or C groove or mounting option B.

The mounting screw (M12) should be tightened with torque 91 Nm.

Volvo Part No.	Order No.	Ø a	b	c	d	e	f	g	Ø h
3044223	S-3000	95.4	25	67.5	62.5	195	170	12.5	13

Note! For dimensions on mounting possibilities K-3000, KU-3000, FU-3000, FAC-3000, SA-3000, HM-3000 and FCSC-3000 refer to Chapter 3.

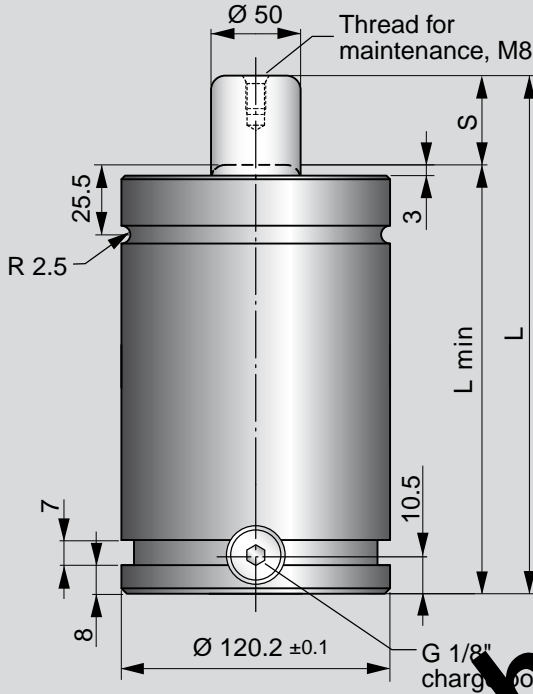

TB springs have a larger gas volume than our standard TU series. This reduces the pressure increase as the piston rod is stroked. It also increases the service life of the spring.

TB springs are recommended for applications where a low force increase is desirable. TB springs are also a good choice for higher cycle rates and high volume production.

Note! When ordering mounts for TB 3000 springs, a mount of a larger size than the spring must be used.

Being phased out!

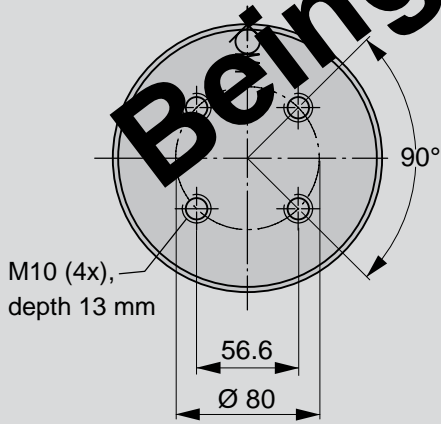

Volvo Part No.	Order No.	S Stroke	Force in N at 150 bar/+20°C		L ±0.25	L min	Gas vol. (l)	Weight (kg)
			Initial	End force*				
3044156	TB 3000-025	25	30000	39000	170	145	0.25	10.65
3044157	TB 3000-038	38.1		39000	196.2	158.1	0.36	11.25
3044158	TB 3000-050	50		39000	220	170	0.45	11.65
3044159	TB 3000-064	63.5		40000	247	183.5	0.55	12.30
3044160	TB 3000-080	80		40000	280	200	0.68	13.00
3044161	TB 3000-100	100		39000	320	220	0.83	13.70
3044162	TB 3000-125	125		39000	370	245	1.03	14.75
3044163	TB 3000-160	160		39000	440	280	1.30	16.05
	TB 3000-200	200		39000	520	320	1.62	17.75
	TB 3000-250	250		39000	620	370	2.01	19.80
	TB 3000-300	300		39000	720	420	2.41	21.85

Basic Information

- For general information see "About gas springs", 2.1
- Pressure medium Nitrogen
- Max. charging pressure 150 bar
- Min. charging pressure 25 bar
- Operating temperature 0 to +80°C
- Force increase by temperature ±0.3%/°C
- Recommended max strokes/min ~ 40-80 (at 20°C)
- Max piston rod velocity 1.6 m/s
- Rod surface Nitrided
- Tube surface Black oxide
- Repair kits
- *TB 3000 new version 3019237
- Repair kit. Volvo Part No. 3050724
- TB 3000 old version 2014068-07
- Repair kit. Volvo Part No. 3044230
- *New version is identified by circular rings on the top of tube, guide and rod.

Mounting Possibilities

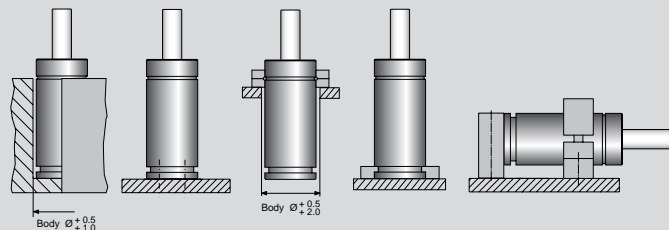

- Drop - In
- Base Mount
B, MP
- Top Mount
FC, FCS,
FCSC
- Foot Mount
K, KU, FFC,
FU
- Body Mount
FAC, SA, S

Note! For dimensions on mounting possibilities K-5000, KU-5000, FU-5000, FAC-5000, SA-5000 and FCSC-5000 refer to Chapter 3.

MP
ISO

Note! Comes complete with screws to mount gas spring.

Order No.	a	b
MP-5000	140	109.5

FC
ISO

Order No.	Ø a	Ø b	c	Ø d	e	f
FC-5000	175	155	109.5	13.5	21	36

FCS
ISO

Volvo Part No.	Order No.	Ø a	b	c	Ø d	e	f
3044692	FCS-5000	155	130	109.5	13.5	21	36

FFC
ISO

Volvo Part No.	Order No.	a	b	Ø c	Ø d	e	f
3054003	FFC-5000	140	109.5	155	13.5	24	12

S
ISO

Note! Support S is designed to be used in combination with flanges mounted in the U or C groove or mounting option B.

The mounting screw (M12) should be tightened with torque 91 Nm.

Volvo Part No.	Order No.	Ø a	b	c	d	e	f	g	Ø h
3044224	S-5000	120.4	27.5	77.5	74	220	195	12.5	13

Note! For dimensions on mounting possibilities K-5000, KU-5000, FU-5000, FAC-5000, SA-5000 and FCSC-5000 refer to Chapter 3.

SL 3000



The SL 3000 spring has an "inch-based" total length and stroke length.

The SL 3000 has a total length of 101.6 mm + (2 x stroke).

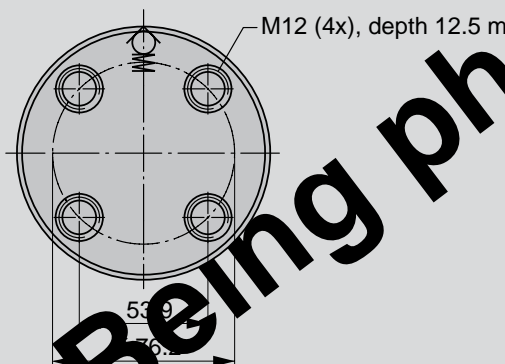
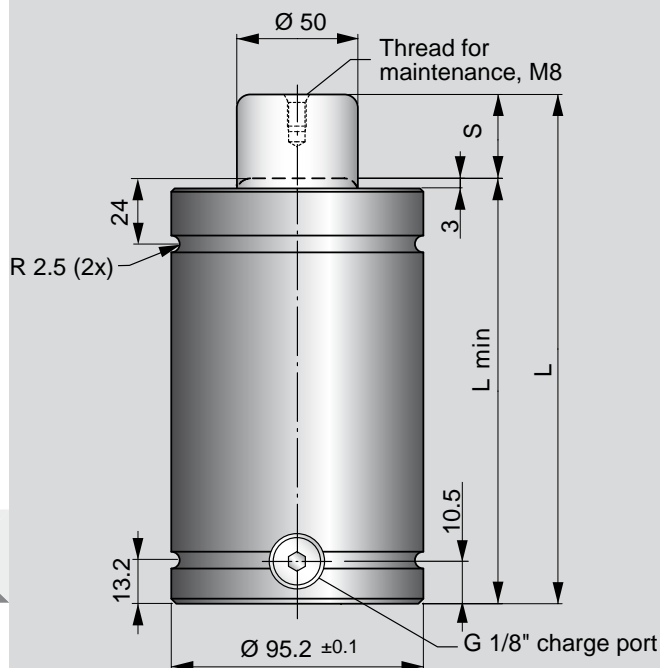

Order no.	Stroke	Force in N at 150 bar/+20°C		L ±0.25	L min	Gas vol. (l)	Weight (kg)
		Initial	End force*				
SL 3000-013	12.7		43000	127	114.3	0.11	5.50
SL 3000-025	25.4		45000	152.4	127	0.17	5.90
SL 3000-038	38.1		46000	177.8	139.7	0.23	6.30
SL 3000-051	50.8		48000	203.2	152.4	0.29	6.60
SL 3000-064	63.5		49000	228.6	165.1	0.35	7.00
SL 3000-076	76.2		49000	254	177.8	0.41	7.40
SL 3000-089	88.9		49000	279.4	190.5	0.48	7.70
SL 3000-102	101.6		49000	304.8	203.2	0.54	8.10
SL 3000-114	114.3		49000	330.2	215.9	0.61	8.50
SL 3000-127	127		49000	355.6	228.6	0.67	8.90
SL 3000-140	139.7		49000	381	241.3	0.73	9.20
SL 3000-152	152.4		49000	406.4	254	0.80	9.60
SL 3000-165	165.1		49000	431.8	266.7	0.86	10.00
SL 3000-178	177.8		49000	457.2	279.4	0.93	10.40

Basic Information

For general information see "About gas springs", 2.1
 Pressure medium Nitrogen
 Max. charging pressure 150 bar
 Min. charging pressure 25 bar
 Operating temperature 0 to +80°C
 Force increase by temperature ±0.3%/°C
 Recommended max strokes/min ~ 15-40 (at 20°C)
 Max piston rod velocity 1.6 m/s

Rod surface Nitrided
 Tube surface Yellow chromed

Repair kits

* SL 3000 new version 4019339
 SL 3000 old version 2014979-3000

*New version is identified by circular rings on the top of tube, guide and rod.

Mounting Possibilities

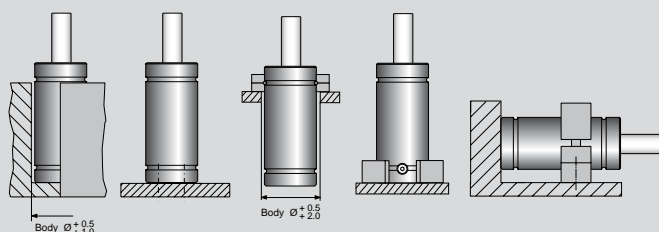

Drop - In

Base Mount

Top Mount

Foot Mount

Body Mount

B

FC, FCS,

FSL

S

FCSC

Note! For dimensions on mounting possibility FCSC-3000 refer to Chapter 3.

FC ISO

Order No.	Ø a	Ø b	c	Ø d	e	f
FC-3000	150	130	92	13.5	18	33

FCS ISO

Order No.	Ø a	b	c	Ø d	e	f
FCS-3000	130	110	92	13,5	18	33

FSL

Order No.	a	b	Ø c	d	Ø e	Ø f	g	h	i	j
FSL-3000	127	98.3	139	61	20	13.5	13	25	25.7	25.7

S ISO

Note! Support S is designed to be used in combination with flanges mounted in the U or C groove or mounting option B.

The mounting screw (M12) should be tightened with torque 91 Nm.

Order No.	Ø a	b	c	d	e	f	g	Ø h
S-3000	95.4	25	67.5	62.5	195	170	12.5	13

Note! For dimensions on mounting possibility FCSC-3000 refer to Chapter 3.

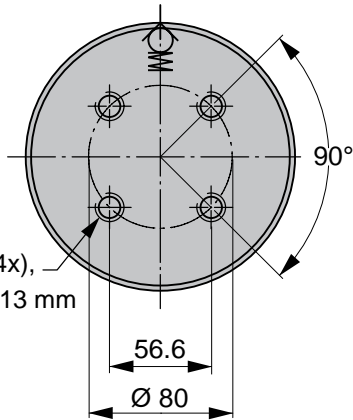
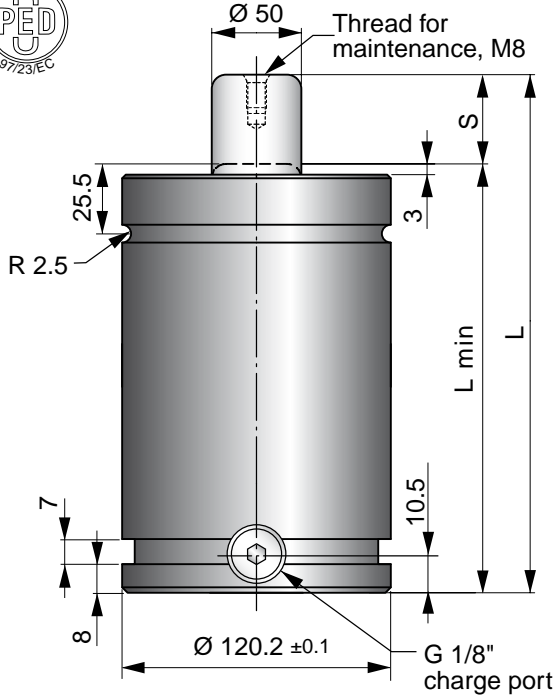

Speed Control™ – SPC gas springs have been engineered to eliminate blank holder bounce, commonly associated with increased return stroke speeds from link drive presses.

SPC gas springs have inbuilt return stroke **speed dampening**, which decelerates the last 30 mm of piston rod stroke to 0.4 m/s, helping to bring the blank holder to a smooth stop.

Speed Control™ – SPC features:

- Eliminate blank holder bounce
- Increase productivity by increasing part transfer efficiency
- Easily retrofitted to existing dies
- Stroke lengths 125 to 300 mm
- Linkable using hose-system

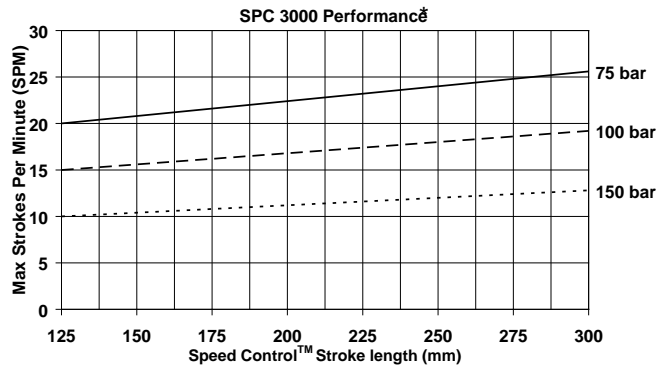

*At ambient room temperatures with free air flow

Order No.	S Stroke	Force in N at 150 bar/+20°C		L ±0.25	L min	Gas vol. (l)	Weight (kg)
		Initial	End force*				
SPC 3000-125	125	30000	38000	390	265	1.15	10.64
SPC 3000-160	160		38000	460	300	1.43	11.30
SPC 3000-200	200		38000	540	340	1.74	12.06
SPC 3000-250	250		39000	640	390	2.14	13.00
SPC 3000-300	300		39000	740	440	2.53	13.95

*at full stroke

Basic Information

Mounting Possibilities

For general information see "About gas springs", 2.1
 Pressure medium Nitrogen
 Max. charging pressure 150 bar (at 20°C)
 Min. charging pressure 25 bar (at 20°C)
 Operating temperature 0 to +80°C
 Force increase by temperature..... ±0.3%/°C
 Recommended max strokes/min See chart
 Dampening length ≈ 30 mm
 Dampening speed 0.4 m/s

Rod surface Nitrided
 Tube surface Black oxide
 Repair kit 3021496

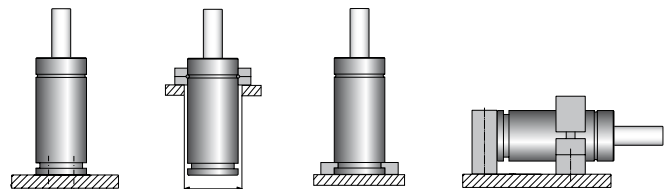

Base Mount
B, MP

Top Mount
FC, FCS, FCSC

Foot Mount
K, KU, FFC, FU

Body Mount
FAC, SA, S

Note! For dimensions on mounting possibilities K-5000, KU-5000, FU-5000, FAC-5000, SA-5000 and FCSC-5000 refer to Chapter 3.

MP

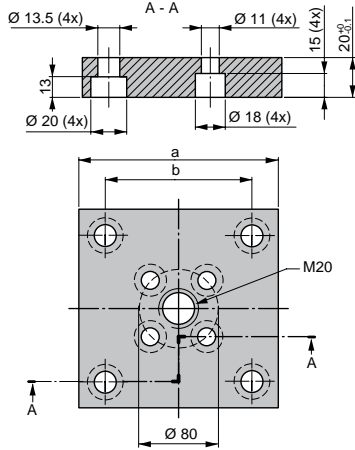

Note! Comes complete with screws to mount gas spring.

Order No.	a	b
MP-5000	140	109.5

FC

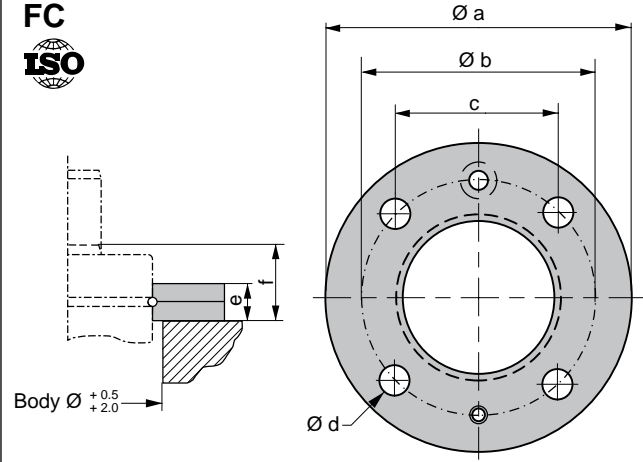

Order No.	Ø a	Ø b	c	Ø d	e	f
FC-5000	175	155	109.5	13.5	21	36

FCS

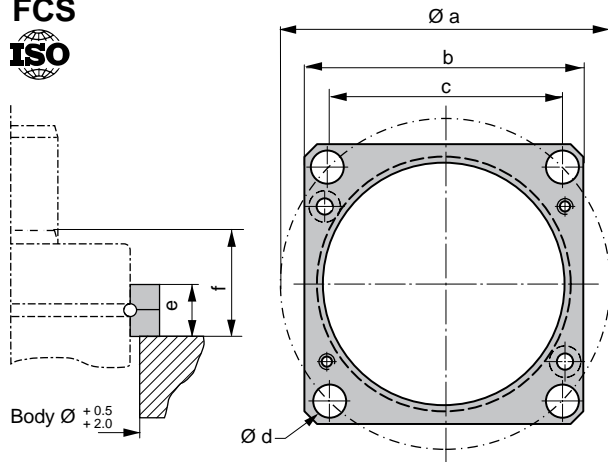

Order No.	Ø a	b	c	Ø d	e	f
FCS-5000	155	130	109.5	13.5	21	36

FFC

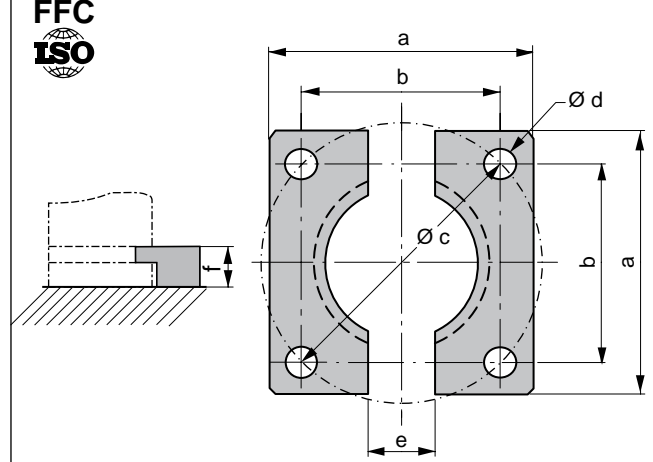

Order No.	a	b	Ø c	Ø d	e	f
FFC-5000	140	109.5	155	13.5	24	12

S



Note! Support S is designed to be used in combination with flanges mounted in the U or C groove or mounting option B.

The mounting screw (M12) should be tightened with torque 91 Nm.

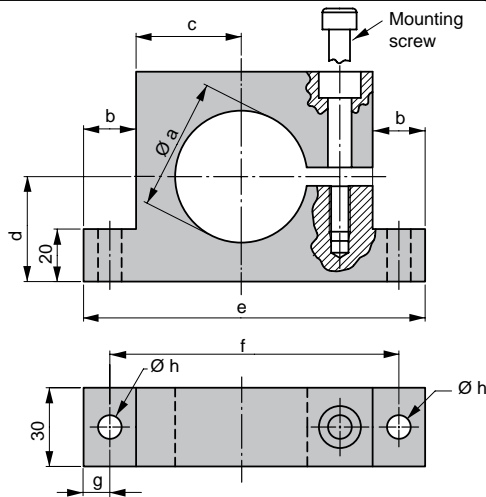



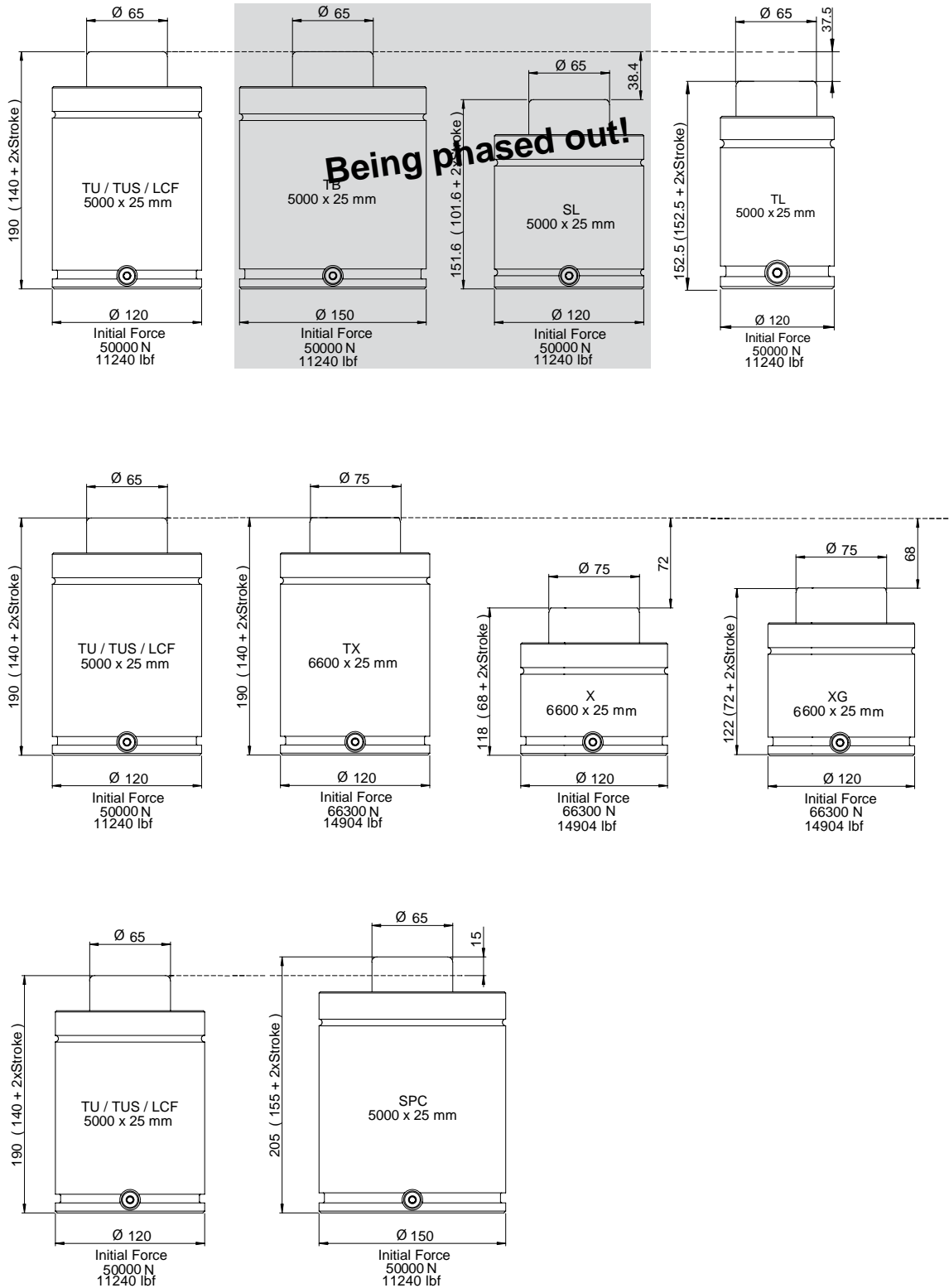

Order No.	Ø a	b	c	d	e	f	g	Ø h
S-5000	120.4	27.5	77.5	74	220	195	12.5	13

Note! For dimensions on mounting possibilities K-3000, KU-3000, FU-3000, FAC-3000, SA-3000 and FCSC-3000 refer to Chapter 3.

Overview - $50000 \leq F_{INIT} < 75000$



$50000 \leq F_{INIT} < 75000$

X 6600		Page 2.8/2
XG 6600		Page 2.8/4
TX 6600		Page 2.8/6
TL 5000		Page 2.8/8
TU 5000		Page 2.8/10
TUS 5000		Page 2.8/12
LCF 5000		Page 2.8/14
TB 5000		Page 2.8/16
SL 5000		Page 2.8/18
SPC 5000		Page 2.8/20

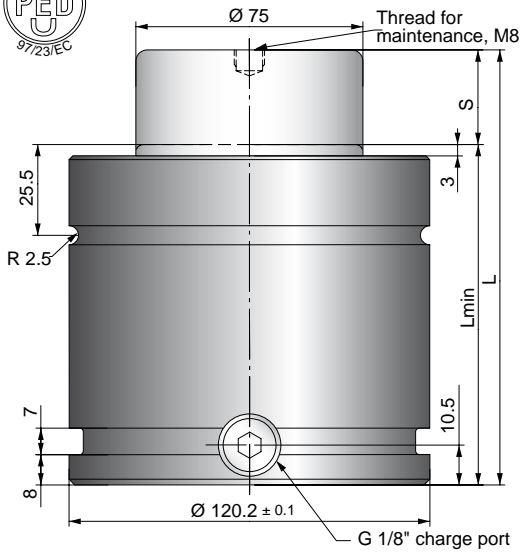

The Power Line series are our shortest and most powerful Piston Rod Sealed gas springs, giving you a great deal of force in a very small amount of space.

These gas springs are available with forces from 1700 N up to 200000 N and stroke lengths between 7 and 125 mm.

There is a side port for gas charging that can also be used to connect to a hose system.

An upper C-groove, lower U-groove together with four M10 threaded holes allow various mounting possibilities using our standard mounts.

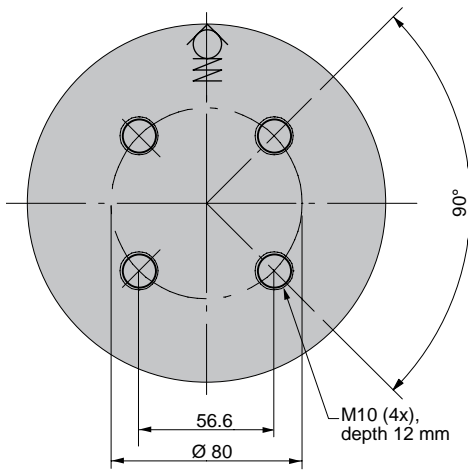

Volvo Part No.	Order No.	S Stroke	Force in N at 150 bar/+20°C		L ±0.25	L min	Gas vol. (l)	Weight (kg)
			Initial	End force*				
	X 6600-016	16	66300	89000	100	84	0.32	5.00
3053975	X 6600-019	19		91000	106	87	0.35	5.11
3053976	X 6600-025	25		93900	118	93	0.42	5.34
3053977	X 6600-032	32		96100	132	100	0.49	5.61
3053978	X 6600-038	38		98200	144	106	0.56	5.84
3053979	X 6600-050	50		100600	168	118	0.69	6.31
3053980	X 6600-063	63		102400	194	131	0.83	6.81
3053981	X 6600-075	75		103400	218	143	0.90	7.27
3053982	X 6600-080	80		104100	228	148	1.01	7.46
3053983	X 6600-100	100		105400	268	168	1.23	8.23
3053984	X 6600-125	125		106500	318	193	1.50	9.19

* = at full stroke

Basic Information

- For general information see "About gas springs", 2.1
- Pressure medium Nitrogen
- Max. charging pressure 150 bar (at 20°C)
- Min. charging pressure 25 bar (at 20°C)
- Operating temperature 0 to +80°C
- Force increase by temperature ±0.3%/°C
- Recommended max strokes/min ... ≈ 30 to 100 (at 20°C)
- Max piston rod velocity 1.6 m/s

- Rod surface Nitrided
- Tube surface Black oxide
- Repair kit 3019912

Repair kit, Volvo Part No 3054851

Mounting Possibilities

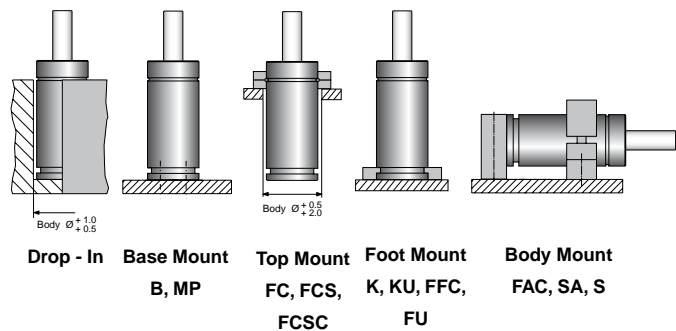

Note! For dimensions on mounting possibilities K-5000, KU-5000, FU-5000 and FCSC-5000 refer to Chapter 3.

MP
ISO

Note! Comes complete with screws to mount gas spring.

Order No.	a	b
MP-5000	140	109.5

FC
ISO

Order No.	Ø a	Ø b	c	Ø d	e	f
FC-5000	175	155	109.5	13.5	21	36

FCS
ISO

Volvo Part No.	Order No.	Ø a	b	c	Ø d	e	f
3044692	FCS-5000	155	130	109.5	13.5	21	36

FFC
ISO

Volvo Part No.	Order No.	a	b	Ø c	Ø d	e	f
3054003	FFC-5000	140	109.5	155	13.5	24	12

S
ISO

Note! Support S is designed to be used in combination with flanges mounted in the U or C groove or mounting option B.

The mounting screw (M12) should be tightened with torque 91 Nm.

Volvo Part No.	Order No.	Ø a	b	c	d	e	f	g	Ø h
3044224	S-5000	120.4	27.5	77.5	74	220	195	12.5	13

Note! For dimensions on mounting possibilities K-5000, KU-5000, FU-5000 and FCSC-5000 refer to Chapter 3.

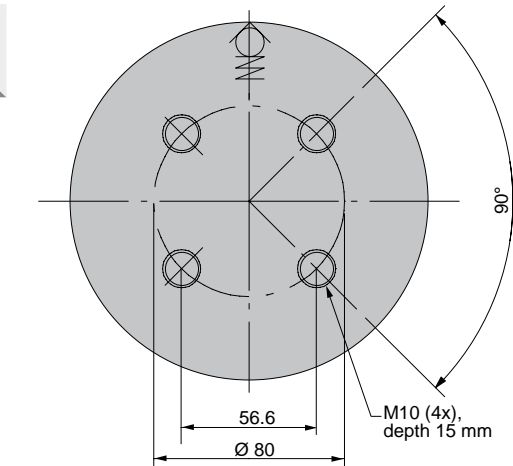
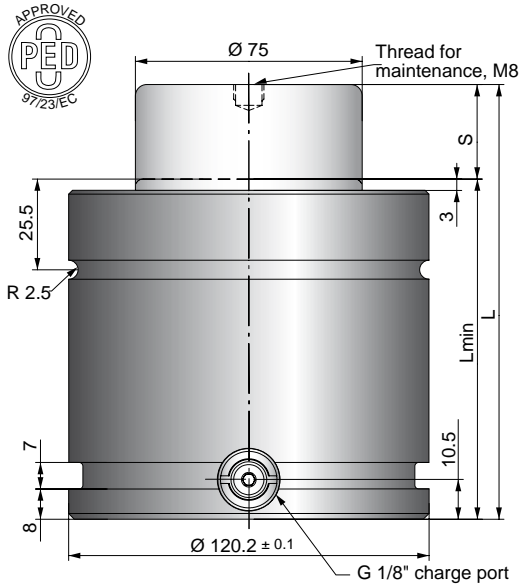

The Power Line series are our shortest and most powerful Piston Rod Sealed gas springs, giving you a great deal of force in a very small amount of space.

These gas springs are available with forces from 3500 N up to 66000 N and stroke length between 10 and 125 mm.

There is a side and a bottom port for gas charging that can also be used to connect to a hose system.

An upper C-groove, lower U-groove together with four M10 threaded holes allow various mounting possibilities using our standard mounts.

8

Order No.	S Stroke	Force in N at 150 bar/+20°C		L ±0.25	L min	Gas vol. (l)	Weight (kg)
		Initial	End force*				
XG 6600-016	16	66300	89000	100	84	0.32	4.97
XG 6600-019	19		91000	106	87	0.35	5.09
XG 6600-025	25		93900	118	93	0.42	5.31
XG 6600-032	32		96100	132	100	0.49	5.58
XG 6600-038	38		98200	144	106	0.56	5.81
XG 6600-050	50		100600	168	118	0.69	6.22
XG 6600-063	63		102400	194	131	0.83	6.78
XG 6600-075	75		103400	218	143	0.90	7.05
XG 6600-080	80		104100	228	148	1.01	7.43
XG 6600-100	100		105400	268	168	1.23	8.20
XG 6600-125	125		106500	318	193	1.50	9.16

* = at full stroke

Basic Information

For general information see "About gas springs", 2.1
 Pressure medium Nitrogen
 Max. charging pressure 150 bar (at 20°C)
 Min. charging pressure 25 bar (at 20°C)
 Operating temperature 0 to +80°C
 Force increase by temperature ±0.3%/°C
 Recommended max strokes/min ... ~ 30 to 100 (at 20°C)
 Max piston rod velocity 1.6 m/s

Rod surface Nitrided
 Tube surface Black oxide
 Repair kit 3019912

Mounting Possibilities

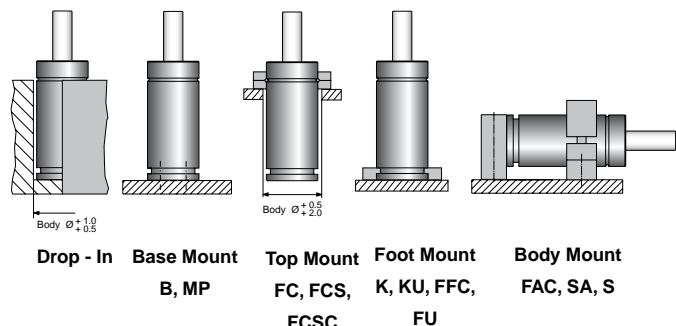

Note! For dimensions on mounting possibilities K, KU, FCSC and FU, refer to chapter 3.

MP
ISO

Note! Comes complete with screws to mount gas spring.

Order No.	a	b
MP-5000	140	109.5

FC
ISO

Order No.	Ø a	Ø b	c	Ø d	e	f
FC-5000	175	155	109.5	13.5	21	36

FCS
ISO

Order No.	Ø a	b	c	Ø d	e	f
FCS-5000	155	130	109.5	13.5	21	36

FFC
ISO

Order No.	a	b	Ø c	Ø d	e	f
FFC-5000	140	109.5	155	13.5	24	12

S
ISO

Note! Support S is designed to be used in combination with flanges mounted in the U or C groove or mounting option B.

The mounting screw (M12) should be tightened with torque 91 Nm.

Order No.	Ø a	b	c	d	e	f	g	Ø h
S-5000	120.4	27.5	77.5	74	220	195	12.5	13

Note! For dimensions on mounting possibilities K, KU, FCSC and FU, refer to chapter 3.

We reserve the right to add, delete or modify components without notification.

All dimensions are stated in mm. All dimensions are nominal unless tolerance is stated.

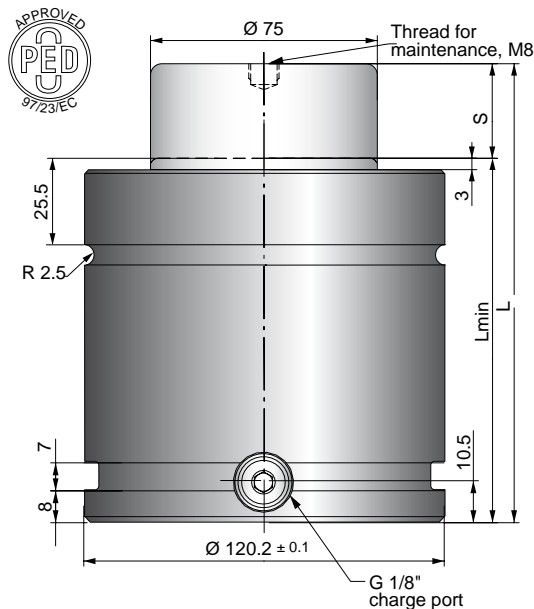

The Power Line - Heavy Duty series is a crossover between the standard TU series and Power Line X series.

These gas springs are available with forces from 9200 N up to 95000 N and stroke lengths between 13 and 300 mm.

There is an optional bottom port for hose/base plate connection.

An upper C-groove, lower U-groove and bottom threaded holes allow various mounting possibilities using our standard mounts.

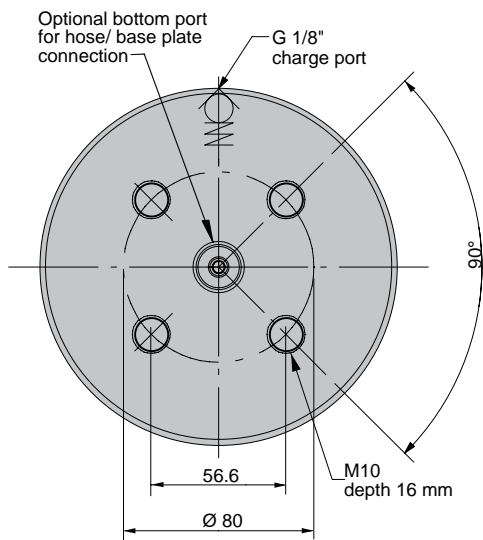

Volvo Part No.	Order No.	S Stroke	Force in N at 150 bar/+20°C		L ±0.25	L min	Gas vol. (l)	Weight (kg)
			Initial	End force*				
3054709	TX 6600-025	25	66300	79558	190	165	0.73	9.28
3054710	TX 6600-038	38		83900	216	178	0.87	9.81
3054711	TX 6600-050	50		87032	240	190	1.00	10.30
3054712	TX 6600-063	63		89758	266	203	1.13	10.83
	TX 6600-075	75		91822	290	215	1.26	11.32
3054713	TX 6600-080	80		92581	300	220	1.31	11.52
3054714	TX 6600-100	100		95155	340	240	1.53	12.33
3054715	TX 6600-125	125		97607	390	265	1.79	13.35
	TX 6600-150	150		99486	440	290	2.05	14.36
3054716	TX 6600-160	160		100121	460	300	2.16	14.77
	TX 6600-175	175		100973	490	315	2.32	15.38
	TX 6600-200	200		102179	540	340	2.58	16.40
3054717	TX 6600-250	250		104015	640	390	3.11	18.43
	TX 6600-300	300		105346	740	440	3.64	20.46

* = at full stroke

Basic Information

For general information see "About gas springs", 2.1
 Pressure medium Nitrogen
 Max. charging pressure 150 bar (at 20°C)
 Min. charging pressure 25 bar (at 20°C)
 Operating temperature 0 to +80°C
 Force increase by temperature ±0.3%/°C
 Recommended max strokes/min ... ~ 30 to 100 (at 20°C)
 Max piston rod velocity 1.6 m/s

Rod surface Nitrided
 Tube surface Black oxide
 Repair kit 3022954

Repair kit. Volvo Part No 3054852

Mounting Possibilities

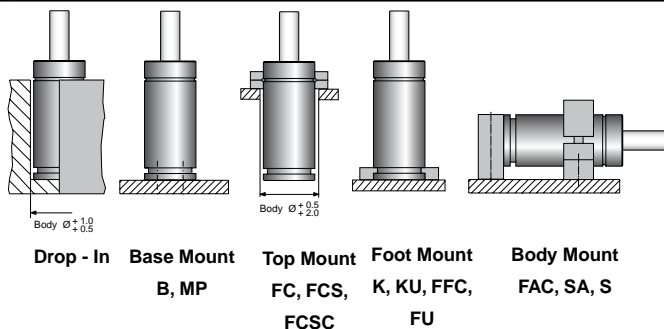

Note! For dimensions on mounting possibilities K, KU, FCSC and FU, refer to chapter 3.

MP
ISO

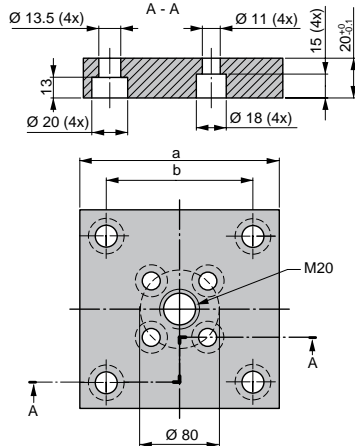

Note! Comes complete with screws to mount gas spring.

Order No.	a	b
MP-5000	140	109.5

FC
ISO

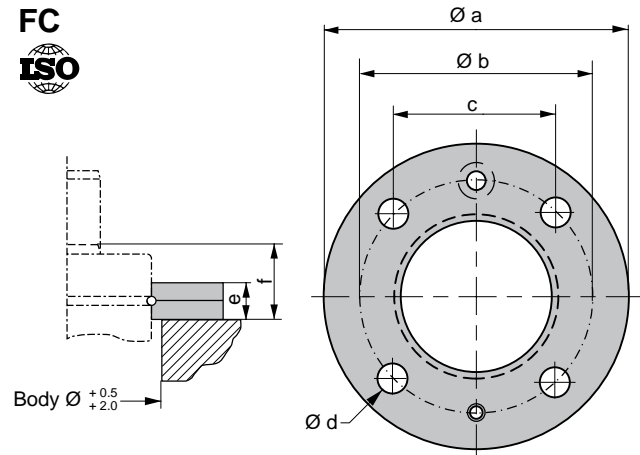

Order No.	Ø a	Ø b	c	Ø d	e	f
FC-5000	175	155	109.5	13.5	21	36

FCS
ISO

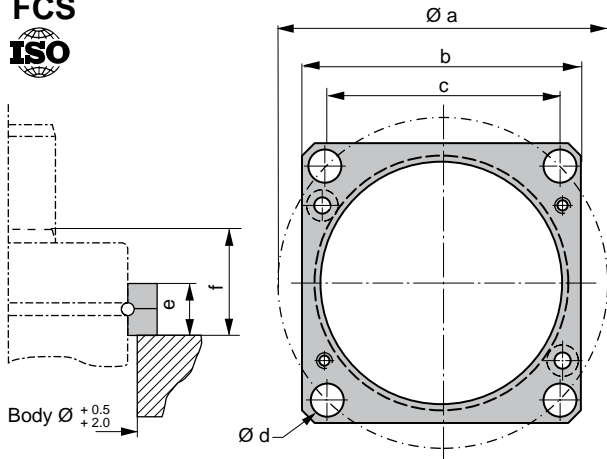

Volvo Part No.	Order No.	Ø a	b	c	Ø d	e	f
3044692	FCS-5000	155	130	109.5	13.5	21	36

FFC
ISO

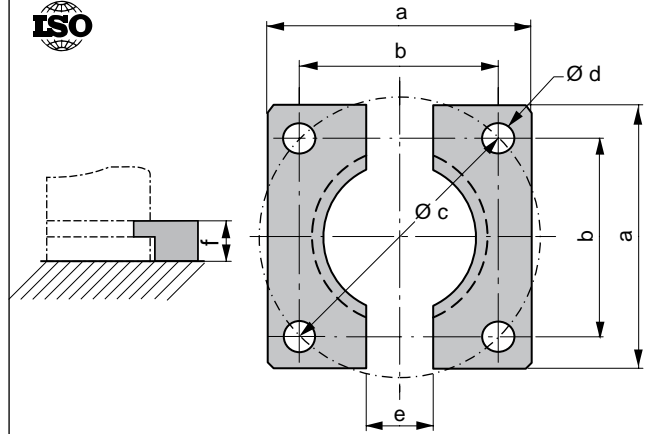

Volvo Part No.	Order No.	a	b	Ø c	Ø d	e	f
3054003	FFC-5000	140	109.5	155	13.5	24	12

S
ISO

Note! Support S is designed to be used in combination with flanges mounted in the U or C groove or mounting option B.

The mounting screw (M12) should be tightened with torque 91 Nm.

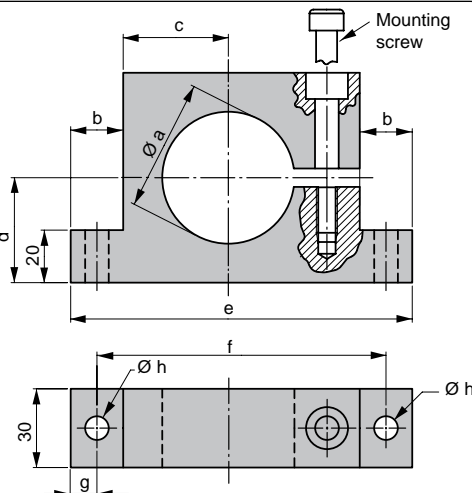

Volvo Part No.	Order No.	Ø a	b	c	d	e	f	g	Ø h
3044224	S-5000	120.4	27.5	77.5	74	220	195	12.5	13

Note! For dimensions on mounting possibilities K, KU, FCSC and FU, refer to chapter 3.

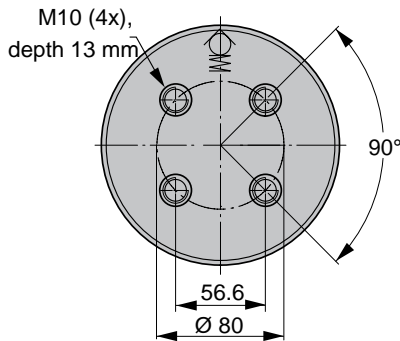
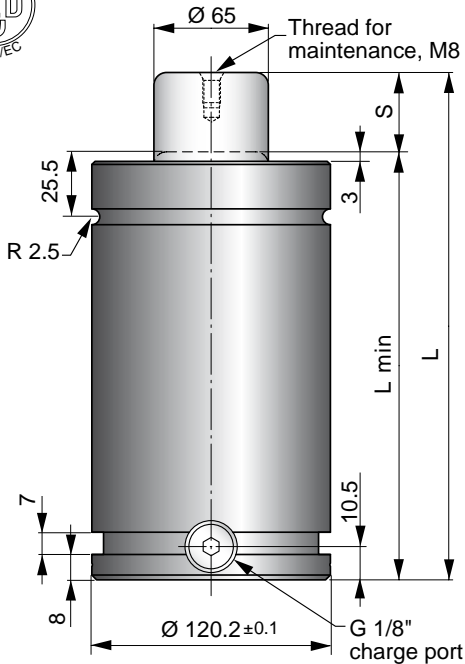

The TL series ranges from model sizes 750 to 5000, with the same features and technology as the TU series.

At the same time, the TL gas spring is shorter than the corresponding TU gas spring by 25 mm, except TL 5000 which is 37.5 mm shorter. TL springs share the same TU mounting possibilities and stroke lengths, with exception of strokes 12.5, 37.5 and 62.5.

Order No.	S Stroke	Force in N at 150 bar/+20°C		L ±0.25	L min	Gas vol. (l)	Weight (kg)
		Initial	End force*				
TL 5000-025	25		80088	152.5	127.5	0.2	5.09
TL 5000-038	37.5		81913	177.5	140	0.3	5.17
TL 5000-050	50		82817	202.5	152.5	0.4	5.26
TL 5000-063	62.5		83461	227.5	165	0.5	5.34
TL 5000-075	75		83839	252.5	177.5	0.6	5.43
TL 5000-080	80		83971	262.5	182.5	0.7	5.46
TL 5000-088	87.5		84143	277.5	190	0.7	5.51
TL 5000-100	100		84374	302.5	202.5	0.8	5.60
TL 5000-113	112.5	49775	84556	327.5	215	0.9	5.68
TL 5000-125	125		84703	352.5	227.5	1.0	5.77
TL 5000-138	137.5		84825	377.5	240	1.1	5.85
TL 5000-150	150		84926	402.5	252.5	1.2	5.94
TL 5000-160	160		84997	422.5	262.5	1.3	6.01
TL 5000-175	175		85087	452.5	277.5	1.4	6.11
TL 5000-200	200		85209	502.5	302.5	1.6	6.28
TL 5000-225	225		85304	552.5	327.5	1.8	6.45
TL 5000-250	250		85381	602.5	352.5	2.0	6.62

* = at full stroke

Basic Information

- For general information see "About gas springs", 2.1
- Pressure medium Nitrogen
- Max. charging pressure 150 bar
- Min. charging pressure..... 25 bar
- Operating temperature 0 to +80°C
- Force increase by temperature ±0.3%/°C
- Recommended max strokes/min ~ 15-40 (at 20°C)
- Max piston rod velocity 1.6 m/s
- Rod surface..... Nitrided
- Tube surface Black oxide
- Repair kit..... 3024178

Mounting Possibilities

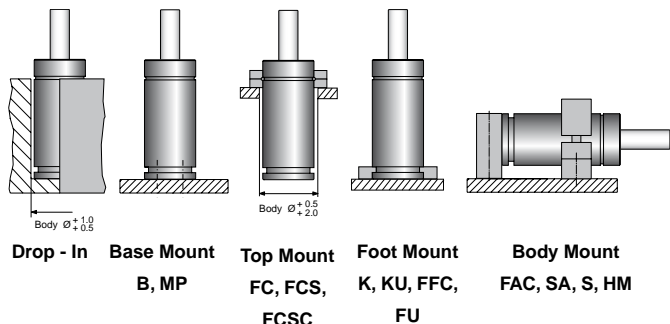

Note! For dimensions on mounting possibilities K-5000, KU-5000, FU-5000, FAC-5000, SA-5000 and FCSC-5000 refer to Chapter 3.

MP
ISO

Note! Comes complete with screws to mount gas spring.

Order No.	a	b
MP-5000	140	109.5

FC
ISO

Order No.	Ø a	Ø b	c	Ø d	e	f
FC-5000	175	155	109.5	13.5	21	36

FCS
ISO

Order No.	Ø a	b	c	Ø d	e	f
FCS-5000	155	130	109.5	13.5	21	36

FFC
ISO

Order No.	a	b	Ø c	Ø d	e	f
FFC-5000	140	109.5	155	13.5	24	12

S
ISO

Note! Support S is designed to be used in combination with flanges mounted in the U or C groove or mounting option B.

The mounting screw (M12) should be tightened with torque 91 Nm.

Order No.	Ø a	b	c	d	e	f	g	Ø h
S-5000	120.4	27.5	77.5	74	220	195	12.5	13

Note! For dimensions on mounting possibilities K-5000, KU-5000, FU-5000, FAC-5000, SA-5000 and FCSC-5000 refer to Chapter 3.

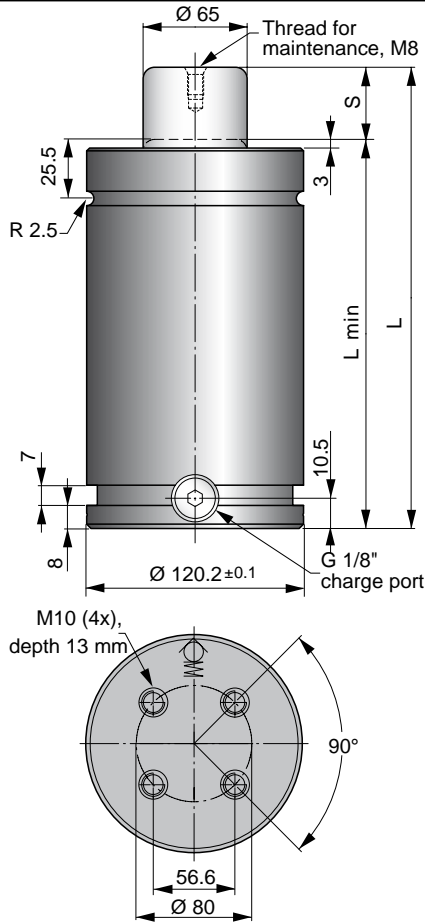

The standard line of gas springs is the TU line. Sizes 250 to 10000 correspond to the ISO 11901 standard for gas springs.

Sizes 750 to 7500 correspond to FORD's, GM's and Renault's automotive gas spring standards. When ordering a Renault standard gas spring add an R to the Order No. (for example: TUR 5000-xxx).
TUR will be replaced by TUS

Being phased out!

TU, TUR and LCF 5000 gas springs are also available with double charging ports. When ordering this type, add a D to the Order No.

For example: TUD 5000-xxx

TUD 5000 example

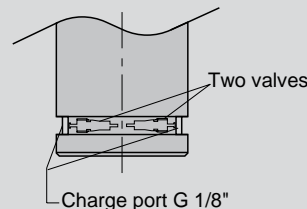

Note! TUD, TURD and LCFD 5000 gas springs have two valves and are delivered charged.

TUR will be replaced by TUS

Volvo part No.	Order No.	S Stroke	Force in N at 150 bar/+20°C		L ±0.25	L min	Gas vol. (l)	Weight (kg)	ISO
			Initial	End force*					
9975975	TU 5000-025	25	50000	71000	190	165	0.32	12.40	✓
3044191	TU 5000-038	38.1		75000	216.2	178.1	0.42	13.10	
9975976	TU 5000-050	50		77000	240	190	0.51	13.70	✓
3044192	TU 5000-064	63.5		80000	267	203.5	0.60	14.40	
9975977	TU 5000-080	80		81000	300	220	0.73	15.30	✓
9975978	TU 5000-100	100		82000	340	240	0.89	16.40	✓
9975979	TU 5000-125	125		82000	390	265	1.09	17.70	✓
9975980	TU 5000-160	160		83000	460	300	1.36	19.60	✓
	TU 5000-200	200		84000	540	340	1.68	21.70	
	TU 5000-250	250		84000	640	390	2.07	22.40	
	TU 5000-300	300	84000	740	440	2.46	27.10		

* = at full stroke

Basic Information

- For general information see "About gas springs", 2.1
- Pressure medium Nitrogen
- Max. charging pressure 150 bar
- Min. charging pressure..... 25 bar
- Operating temperature 0 to +80°C
- Force increase by temperature ±0.3%/°C
- Recommended max strokes/min ~ 15-40 (at 20°C)
- Max piston rod velocity 1.6 m/s
- Rod surface..... Nitrided
- Tube surface Black oxide
- Repair kits
- * TU 5000 new version..... 3018876
- Repair kit. Volvo Part No..... 3050721
- TU 5000 old version..... 2014068-04
- Repair kit. Volvo Part No..... 3040926
- *New version is identified by circular rings on the top of tube, guide and rod.

Mounting Possibilities

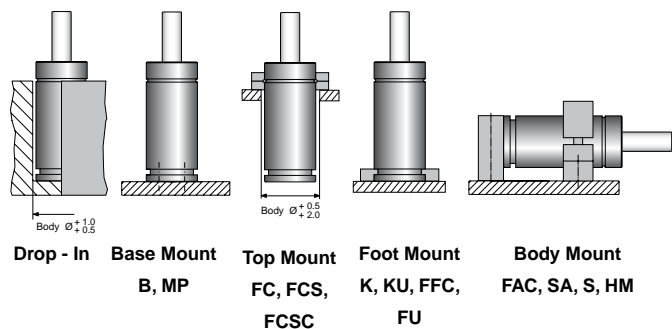

Note! For dimensions on mounting possibilities K-5000, KU-5000, FU-5000, FAC-5000, SA-5000 and FCSC-5000 refer to Chapter 3.

MP
ISO

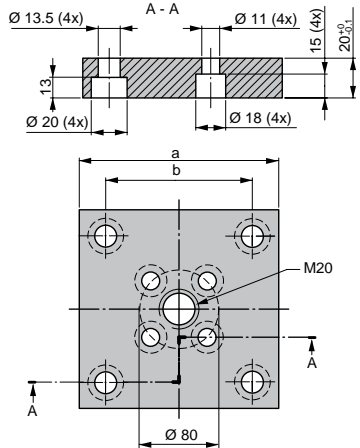

Note! Comes complete with screws to mount gas spring.

Order No.	a	b
MP-5000	140	109.5

FC
ISO

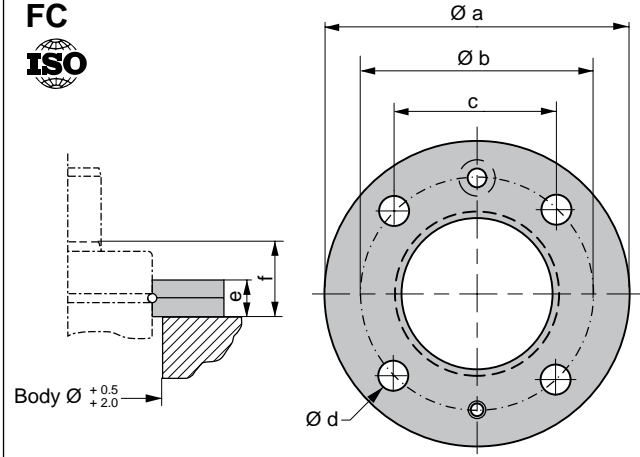

Order No.	Ø a	Ø b	c	Ø d	e	f
FC-5000	175	155	109.5	13.5	21	36

FCS
ISO

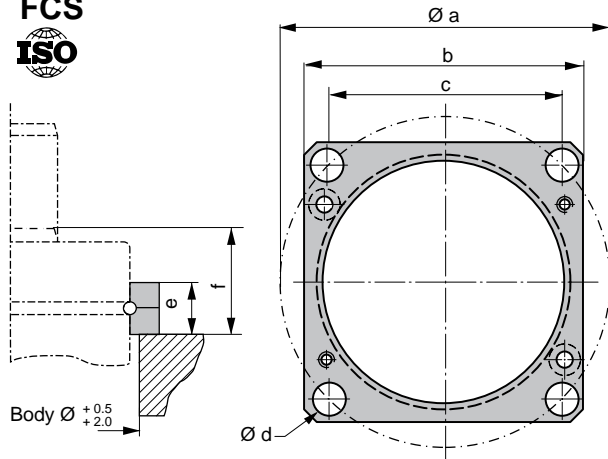

Volvo Part No.	Order No.	Ø a	b	c	Ø d	e	f
3044692	FCS-5000	155	130	109.5	13.5	21	36

FFC
ISO

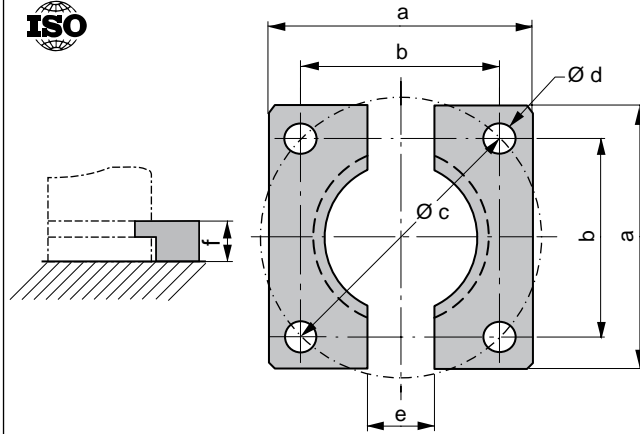

Volvo Part No.	Order No.	a	b	Ø c	Ø d	e	f
3054003	FFC-5000	140	109.5	155	13.5	24	12

S
ISO

Note! Support S is designed to be used in combination with flanges mounted in the U or C groove or mounting option B.

The mounting screw (M12) should be tightened with torque 91 Nm.

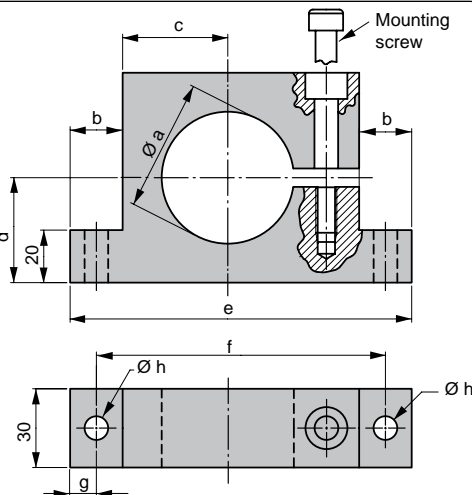

Volvo Part No.	Order No.	Ø a	b	c	d	e	f	g	Ø h
3044224	S-5000	120.4	27.5	77.5	74	220	195	12.5	13

Note! For dimensions on mounting possibilities K-5000, KU-5000, FU-5000, FAC-5000, SA-5000 and FCSC-5000 refer to Chapter 3.

TUS 5000

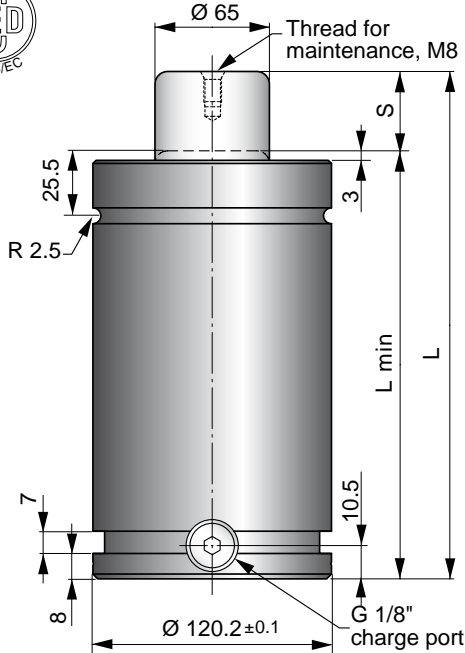

The High Speed gas springs (TUS) are engineered to withstand press stroke speeds to a maximum 2 m/s, which meet the safety demands from the French automotive manufacturer Renault.

These gas springs are available in sizes 750 to 7500 and dimensions correspond to the ISO 11901 standard for gas springs.

TUS gas spring will replace TUR that is being phased out.

8

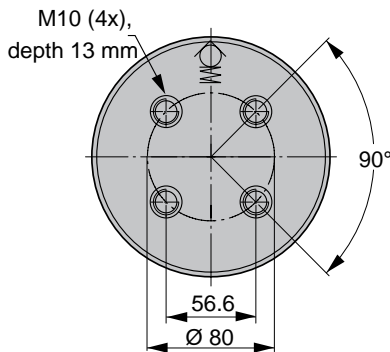

Order No.	S Stroke	Force in N at 150 bar/+20°C		L ±0.25	L min	Gas vol. (l)	Weight (kg)
		Initial	End force*				
TUS 5000-025	25	50000	71000	190	165	0.32	12.00
TUS 5000-038	38.1		75000	216.2	178.1	0.42	12.65
TUS 5000-050	50		77000	240	190	0.51	13.30
TUS 5000-064	63.5		80000	267	203.5	0.60	14.46
TUS 5000-080	80		81000	300	220	0.73	15.05
TUS 5000-100	100		82000	340	240	0.89	16.15
TUS 5000-125	125		82000	390	265	1.09	16.96
TUS 5000-160	160		83000	460	300	1.36	19.40
TUS 5000-200	200		84000	540	340	1.68	20.70
TUS 5000-250	250		84000	640	390	2.07	22.40
TUS 5000-300	300		84000	740	440	2.46	24.66

* = at full stroke

Basic Information

- For general information see "About gas springs", 2.1
- Pressure medium Nitrogen
- Max. charging pressure 150 bar
- Min. charging pressure..... 25 bar
- Operating temperature 0 to +80°C
- Force increase by temperature ±0.3%/°C
- Recommended max strokes/min ~ 15-40 (at 20°C)
- Max piston rod velocity 2 m/s
- Rod surface..... Nitrided
- Tube surface Black oxide
- Repair kit..... 3019280

Mounting Possibilities

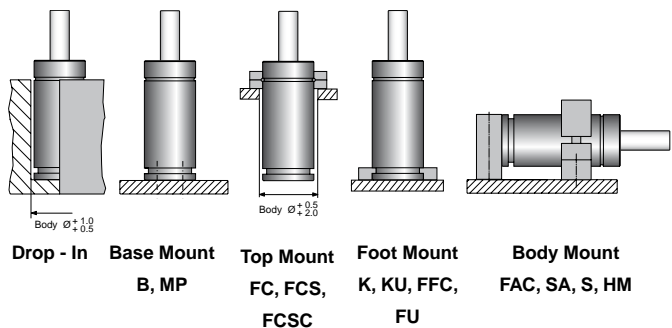

Note! For dimensions on mounting possibilities K-5000, KU-5000, FU-5000, FAC-5000, SA-5000 and FCSC-5000 refer to Chapter 3.

MP
ISO

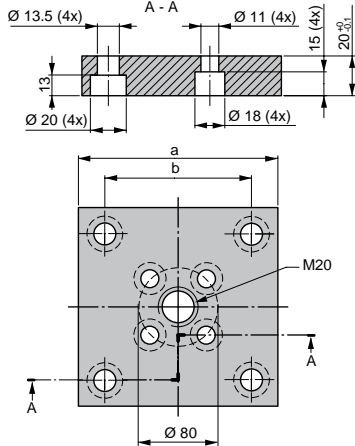

Note! Comes complete with screws to mount gas spring.

Order No.	a	b
MP-5000	140	109.5

FC
ISO

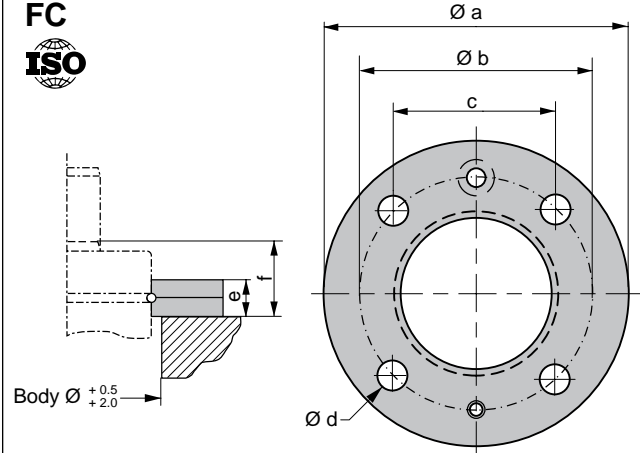

Order No.	Ø a	Ø b	c	Ø d	e	f
FC-5000	175	155	109.5	13.5	21	36

FCS
ISO

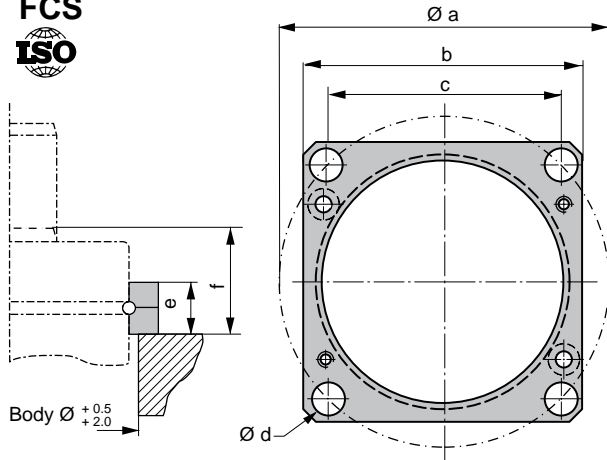

Volvo Part No.	Order No.	Ø a	b	c	Ø d	e	f
3044692	FCS-5000	155	130	109.5	13.5	21	36

FFC
ISO

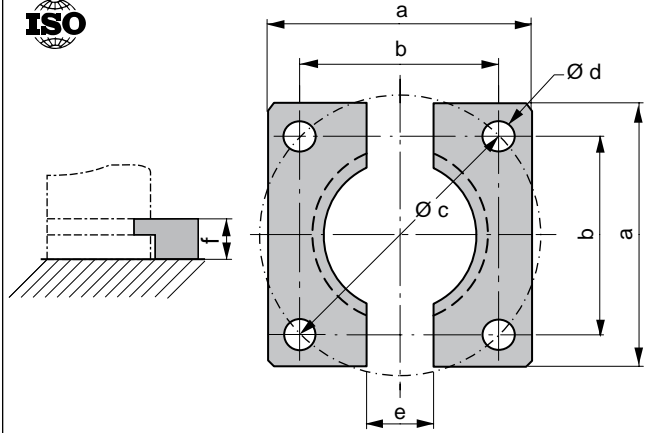

Volvo Part No.	Order No.	a	b	Ø c	Ø d	e	f
3054003	FFC-5000	140	109.5	155	13.5	24	12

S
ISO

Note! Support S is designed to be used in combination with flanges mounted in the U or C groove or mounting option B.

The mounting screw (M12) should be tightened with torque 91 Nm.

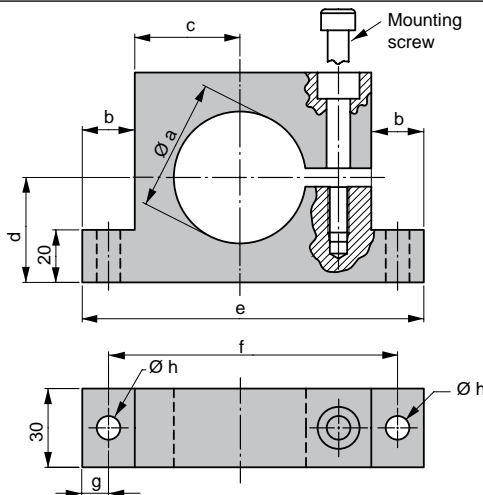

Volvo Part No.	Order No.	Ø a	b	c	d	e	f	g	Ø h
3044224	S-5000	120.4	27.5	77.5	74	220	195	12.5	13

Note! For dimensions on mounting possibilities K-5000, KU-5000, FU-5000, FAC-5000, SA-5000 and FCSC-5000 refer to Chapter 3.

LCF 5000

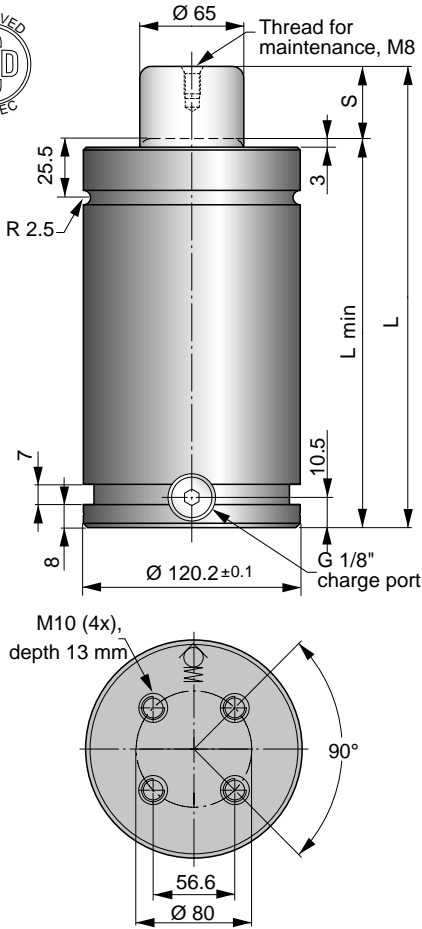

Low Contact Force (LCF) gas springs are designed to reduce excessive shock loads, high noise levels and extreme pad bounce, all factors that lead to high press maintenance costs and noise pollution.

Force vs Stroke for LCF 5000 Springs

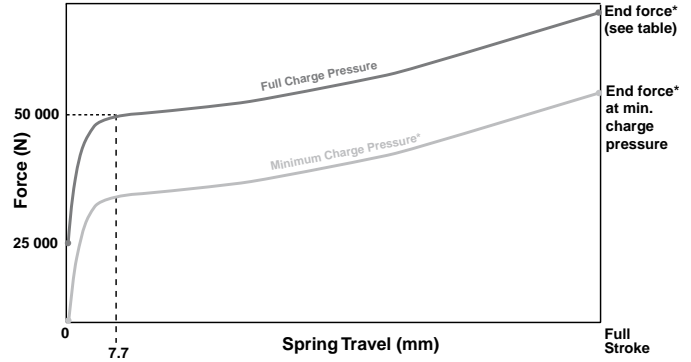

Being phased out!

TU, TUR och LCF 5000 gas springs are also available with double charging ports. When ordering this type, add a D to the Order No.
For example:
LCFD 5000-xxx

LCFD 5000 example

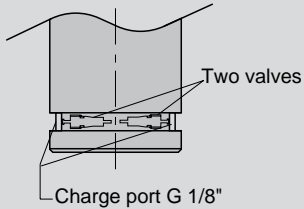

Note! TUD, TURD and LCFD 5000 gas springs have two valves and are delivered charged.

Volvo Part No.	Order No.	S Stroke	Force in N at 150 bar/+20°C		L ±0.25	L min	Gas vol. (l)	Weight (kg)
			Initial	End force*				
	LCF 5000-025	25		71000	190	165	0.32	12.00
	LCF 5000-038	38.1		75000	216.2	178.1	0.42	12.65
	LCF 5000-050	50		77000	240	190	0.51	13.30
	LCF 5000-064	63.5		80000	267	203.5	0.60	14.46
	LCF 5000-080	80		81000	300	220	0.73	15.05
	LCF 5000-100	100	50000	82000	340	240	0.89	16.15
	LCF 5000-125	125		82000	390	265	1.09	16.96
	LCF 5000-160	160		83000	460	300	1.36	19.40
	LCF 5000-200	200		84000	540	340	1.68	20.70
	LCF 5000-250	250		84000	640	390	2.07	22.40
	LCF 5000-300	300		84000	740	440	2.46	24.66

* = at full stroke

Basic Information

Mounting Possibilities

For general information see "About gas springs", 2.1
 Pressure medium Nitrogen
 Max. charging pressure 150 bar
 Min. charging pressure..... 75 bar
 Operating temperature 0 to +80°C
 Force increase by temperature ±0.3%/°C
 Recommended max strokes/min ~ 15-40 (at 20°C)
 Max piston rod velocity 1.6 m/s
 Rod surface..... Nitrided
 Tube surface Black oxide

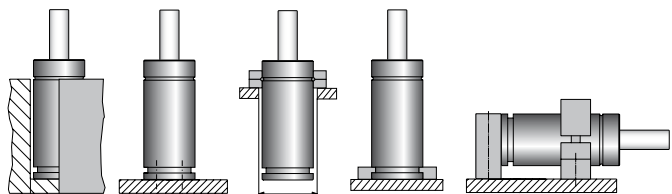

Drop - In **Base Mount** **Top Mount** **Foot Mount** **Body Mount**
 B, MP FC, FCS, FCSC K, KU, FFC, FU FAC, SA, S, HM

Repair kits
 * LCF 5000 new version..... 3019380
 LCF 5000 old version..... 3019133
 *New version is identified by circular rings on the top of tube, guide and rod.

Note! For dimensions on mounting possibilities K-5000, KU-5000, FU-5000, FAC-5000, SA-5000 and FCSC-5000 refer to Chapter 3.

MP
ISO

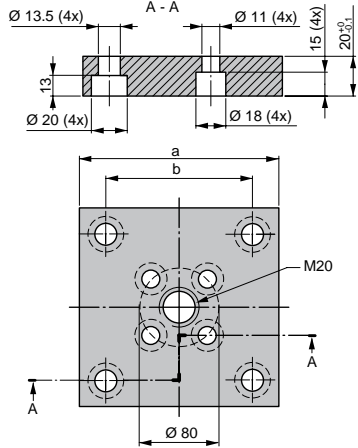

Note! Comes complete with screws to mount gas spring.

Order No.	a	b
MP-5000	140	109.5

FC
ISO

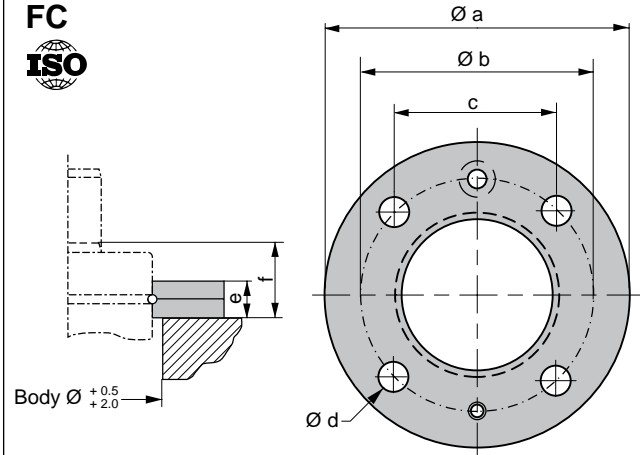

Order No.	Ø a	Ø b	c	Ø d	e	f
FC-5000	175	155	109.5	13.5	21	36

FCS
ISO

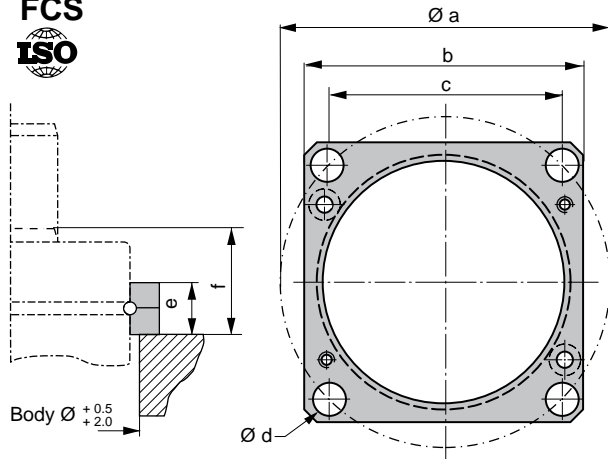

Volvo Part No.	Order No.	Ø a	b	c	Ø d	e	f
3044692	FCS-5000	155	130	109.5	13.5	21	36

FFC
ISO

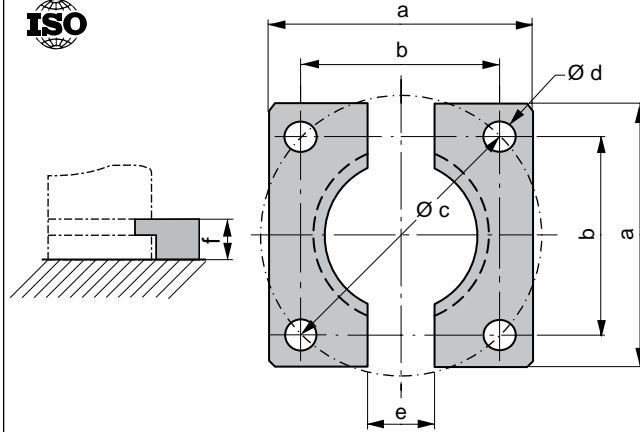

Volvo Part No.	Order No.	a	b	Ø c	Ø d	e	f
3054003	FFC-5000	140	109.5	155	13.5	24	12

S
ISO

Note! Support S is designed to be used in combination with flanges mounted in the U or C groove or mounting option B.

The mounting screw (M12) should be tightened with torque 91 Nm.

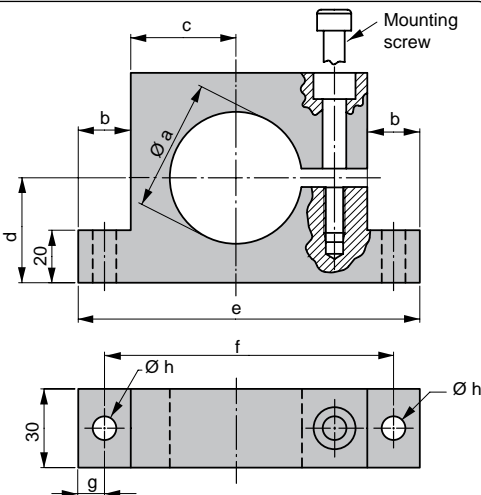

Volvo Part No.	Order No.	Ø a	b	c	d	e	f	g	Ø h
3044224	S-5000	120.4	27.5	77.5	74	220	195	12.5	13

Note! For dimensions on mounting possibilities K-5000, KU-5000, FU-5000, FAC-5000, SA-5000 and FCSC-5000 refer to Chapter 3.

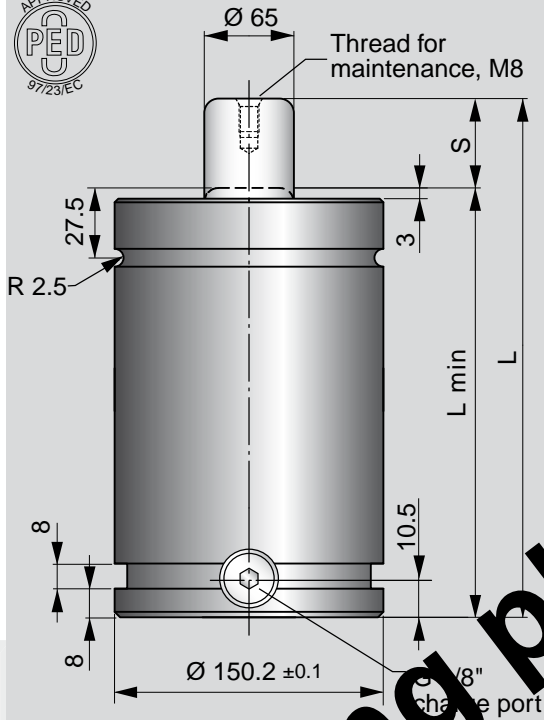

TB springs have a larger gas volume than our standard TU series. This reduces the pressure increase as the piston rod is stroked. It also increases the service life of the spring.

TB springs are recommended for applications where a low force increase is desirable. TB springs are also a good choice for higher cycle rates and high volume production.

Note! When ordering mounts for TB 5000 springs, a mount of a larger size than the spring must be used.

Being phased out!

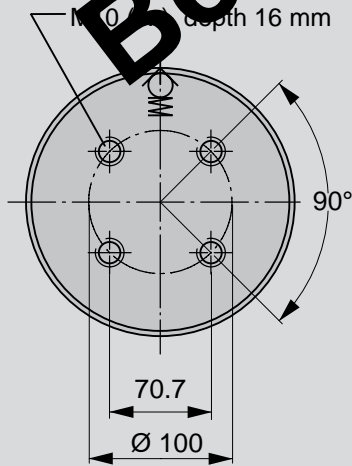

Volvo Part No.	Order No.	S Stroke	Force in N at 150 bar/+20°C		L ±0.25	L min	Gas vol. (l)	Weight (kg)
			Initial	End force*				
3044164	TB 5000-025	25	50000	70000	190	165	0.41	10.98
3044165	TB 5000-038	38.1		69000	216.2	178.1	0.57	11.09
3044166	TB 5000-050	50		69000	240	190	0.72	11.20
3044167	TB 5000-064	63.5		69000	267	203.5	0.86	11.31
3044168	TB 5000-080	80		69000	300	220	1.07	11.46
3044169	TB 5000-100	100		69000	340	240	1.31	11.63
3044170	TB 5000-125	125		69000	390	265	1.62	11.85
3044171	TB 5000-160	160		69000	460	300	2.05	12.16
	TB 5000-200	200		69000	540	340	2.54	12.51
	TB 5000-250	250		68000	640	390	3.16	12.95
	TB 5000-300	300	68000	740	440	3.77	13.38	

* = at full stroke

Basic Information

- For general information see "About gas springs", 2.1
- Pressure medium Nitrogen
- Max. charging pressure..... 150 bar
- Min. charging pressure 25 bar
- Operating temperature 0 to +80°C
- Force increase by temperature ±0.3%/°C
- Recommended max strokes/min ≈40-80 (at 20°C)
- Max piston rod velocity 1.6 m/s
- Rod surface..... Nitrided
- Tube surface Black oxide
- Repair kits
- * TB 5000 new version 3019238
- Repair kit. Volvo Part No..... 3050725**
- TB 5000 old version 2014068-08
- Repair kit. Volvo Part No..... 3044231**

Mounting Possibilities

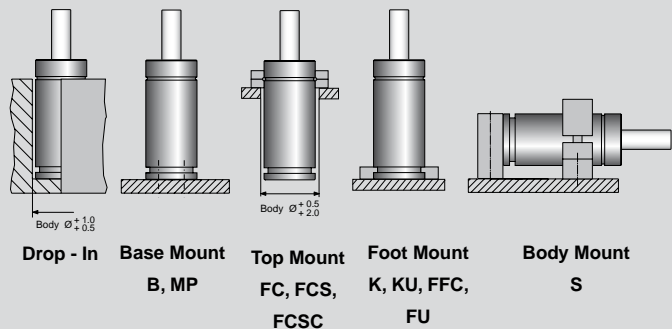

Note! For dimensions on mounting possibilities K-7500, KU-7500, FU-7500 and FCSC-7500 refer to Chapter 3.

MP
ISO

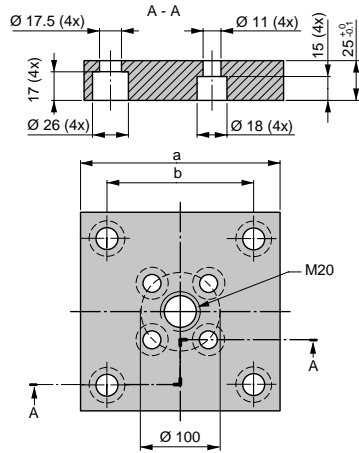

Note! Comes complete with screws to mount gas spring.

Order No.	a	b
MP-7500	190	138

FC
ISO

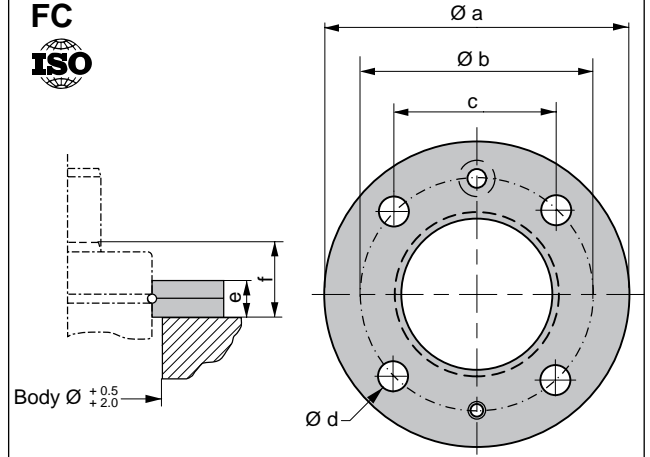

Order No.	Ø a	Ø b	c	Ø d	e	f
FC-7500	220	195	138	17.5	27	41

FCS
ISO

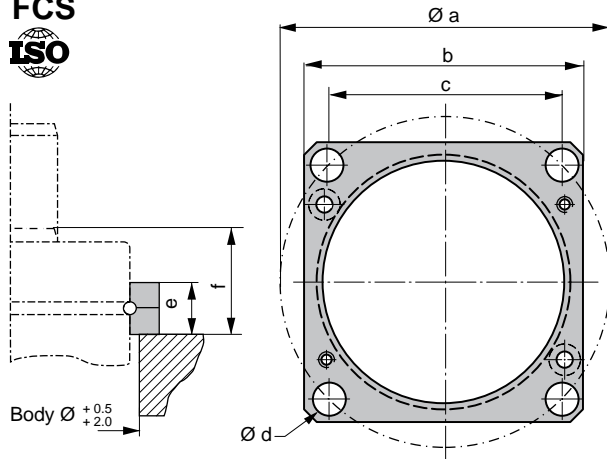

Volvo Part No.	Order No.	Ø a	b	c	Ø d	e	f
3044692	FCS-5000	155	130	109.5	13.5	21	36

FFC
ISO

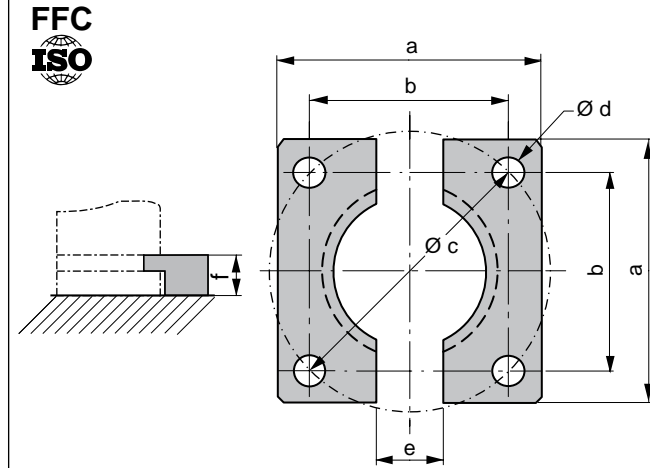

Volvo Part No.	Order No.	a	b	Ø c	Ø d	e	f
3054003	FFC-5000	140	109.5	155	13.5	24	12

S
ISO

Note! Support S is designed to be used in combination with flanges mounted in the U or C groove or mounting option B.

The mounting screw (M12) should be tightened with torque 91 Nm.

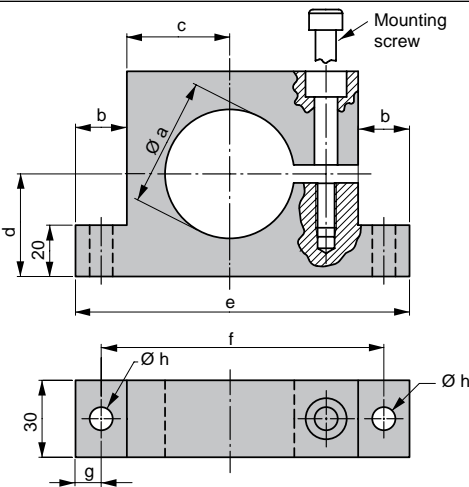

Volvo Part No.	Order No.	Ø a	b	c	d	e	f	g	Ø h
3044224	S-5000	120.4	27.5	77.5	74	220	195	12.5	13

Note! For dimensions on mounting possibilities K-7500, KU-7500, FU-7500 and FCSC-7500 refer to Chapter 3.

FC ISO

Order No.	Ø a	Ø b	c	Ø d	e	f
FC-5000	175	155	109.5	13.5	21	36

FCS ISO

Order No.	Ø a	b	c	Ø d	e	f
FCS-5000	155	130	109.5	13.5	21	36

FSL

Order No.	a	b	Ø c	d	Ø e	Ø f	g	h	i	j
FSL-5000	139.7	114.3	161.8	71	20	13.5	13	22.6	25	25.7

S ISO

Note! Support S is designed to be used in combination with flanges mounted in the C groove or mounting option B.

The mounting screw (M12) should be tightened with torque 91 Nm.

Order No.	Ø a	b	c	d	e	f	g	Ø h
S-5000	120.4	27.5	77.5	74	220	195	12.5	13

Note! For dimensions on mounting possibility FCSC-5000 refer to Chapter 3.

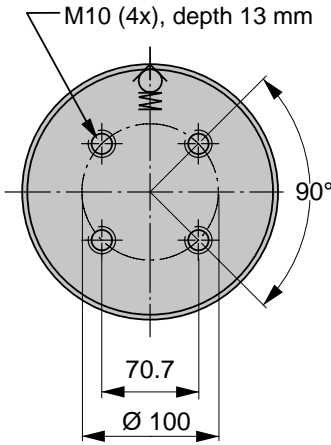
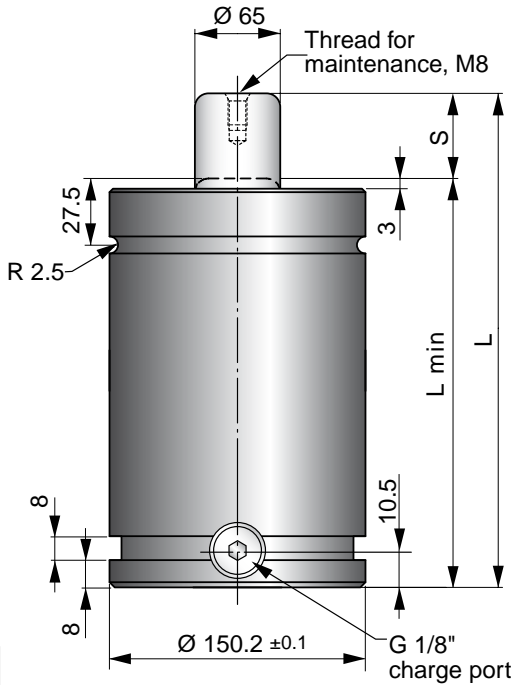

Speed Control™ – SPC gas springs have been engineered to eliminate blank holder bounce, commonly associated with increased return stroke speeds from link drive presses.

SPC gas springs have inbuilt return stroke **speed dampening**, which decelerates the last 30 mm of piston rod stroke to 0.4 m/s, helping to bring the blank holder to a smooth stop.

Speed Control™ – SPC features:

- Eliminate blank holder bounce
- Increase productivity by increasing part transfer efficiency
- Easily retrofitted to existing dies
- Stroke lengths 125 to 300 mm
- Linkable using hose-system

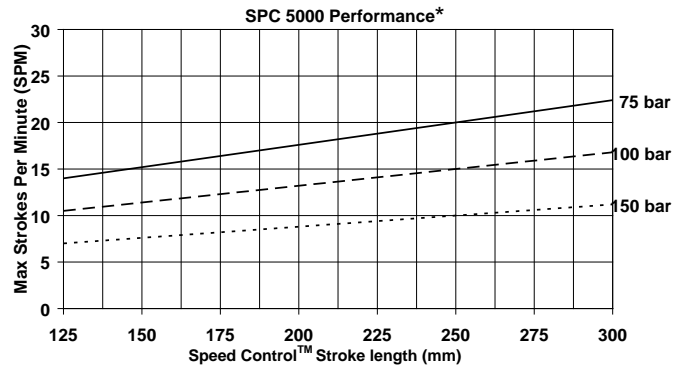

*At ambient room temperatures with free air flow

Order No.	S Stroke	Force in N at 150 bar/+20°C		L ±0.25	L min	Gas vol. (l)	Weight (kg)
		Initial	End force*				
SPC 5000-125	125	50000	64000	405	280	1.90	26.35
SPC 5000-160	160		65000	475	315	2.33	28.75
SPC 5000-200	200		66000	555	355	2.82	31.50
SPC 5000-250	250		66000	655	405	3.43	34.93
SPC 5000-300	300		66000	755	455	4.05	38.37

*at full stroke

Basic Information

For general information see “About gas springs”, 2.1
 Pressure medium Nitrogen
 Max. charging pressure 150 bar (at 20°C)
 Min. charging pressure 25 bar (at 20°C)
 Operating temperature 0 to +80°C
 Force increase by temperature..... ±0.3%/°C
 Recommended max strokes/min See chart
 Dampening length ≈ 30 mm

Rod surface Nitrided
 Tube surface Black oxide
 Repair kit 3021497

Mounting Possibilities

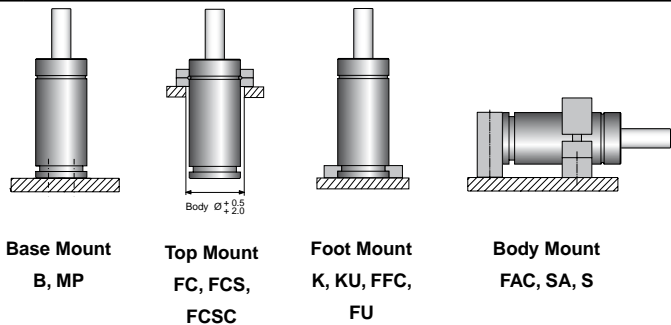

Note! For dimensions on mounting possibilities K-7500, KU-7500, FU-7500, FAC-7500, SA-7500 and FCSC-7500 refer to Chapter 3.

MP
ISO

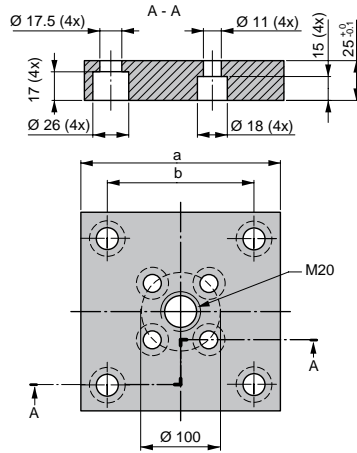

Note! Comes complete with screws to mount gas spring.

Order No.	a	b
MP-7500	190	138

FC
ISO

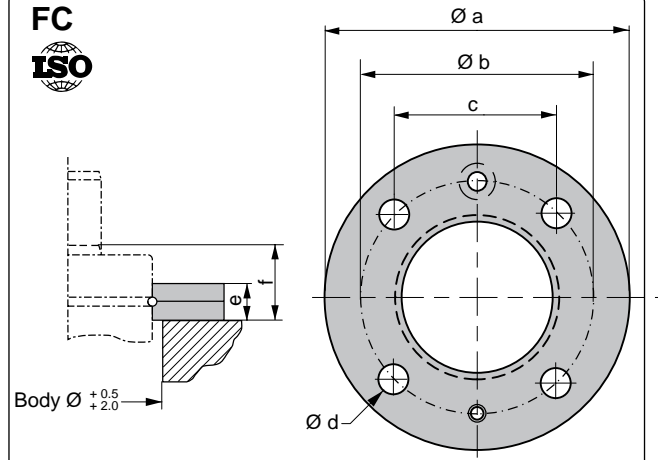

Order No.	Ø a	Ø b	c	Ø d	e	f
FC-7500	220	195	138	17.5	27	41

FCS
ISO

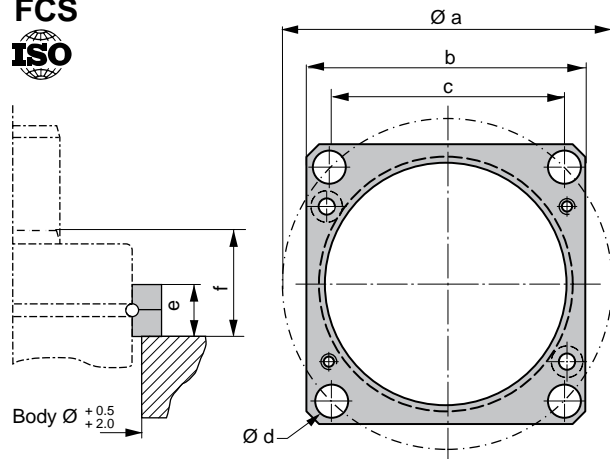

Order No.	Ø a	b	c	Ø d	e	f
FCS-7500	195	162	138	17.5	27	41

FFC
ISO

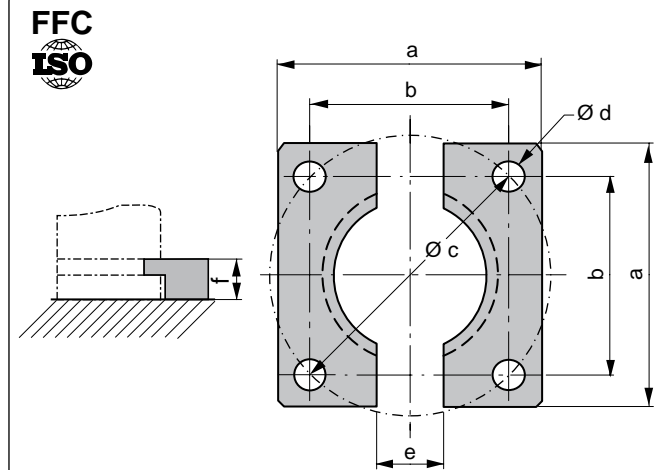

Order No.	a	b	Ø c	Ø d	e	f
FFC-7500	190	138	195.2	17.5	24	12

S
ISO

Note! Support S is designed to be used in combination with flanges mounted in the U or C groove or mounting option B.

The mounting screw (M12) should be tightened with torque 91 Nm.

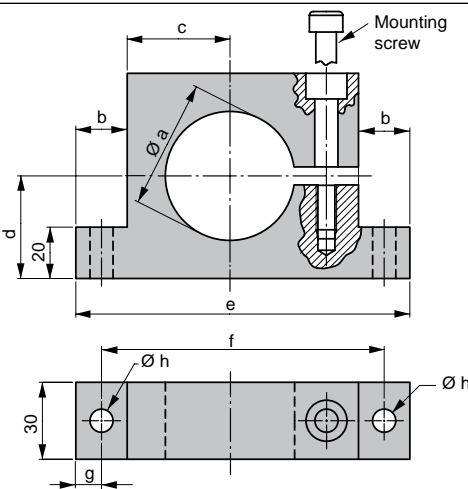





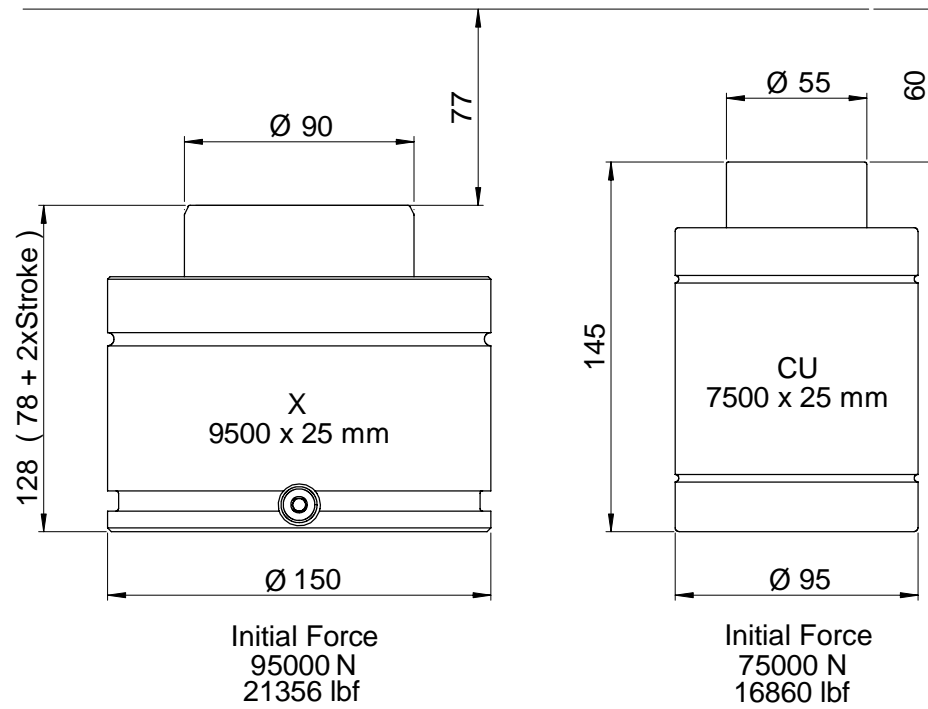
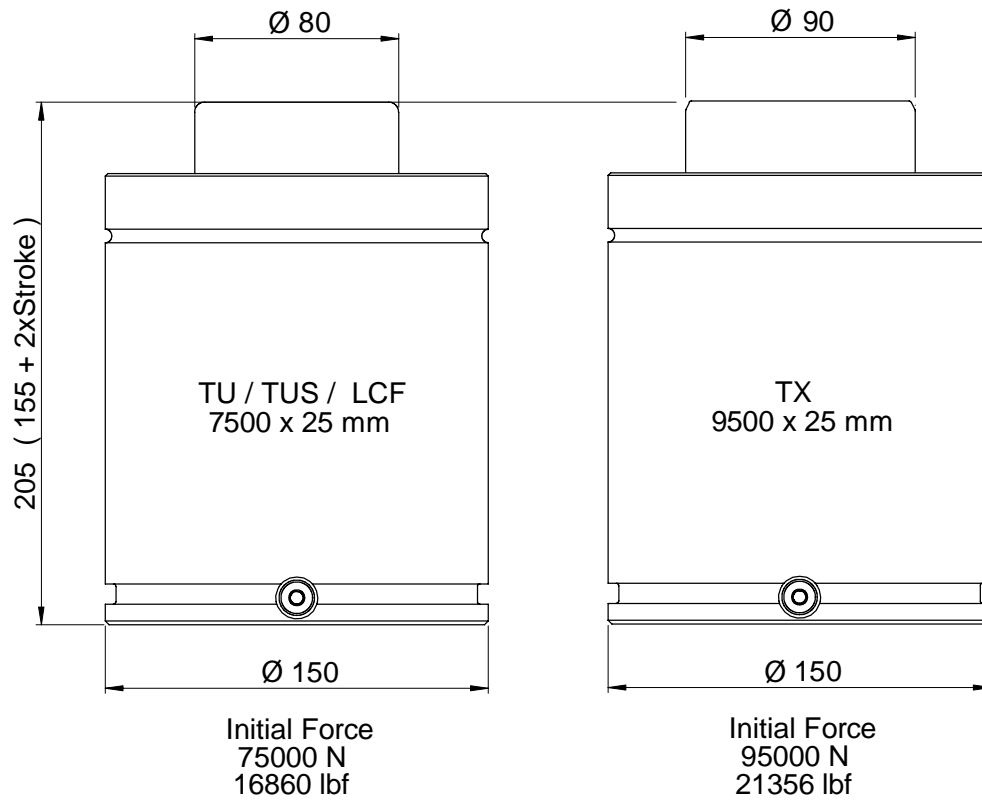

Order No.	Ø a	b	c	d	e	f	g	Ø h
S-7500	150.4	30	95	100	260	230	15	13

Note! For dimensions on mounting possibilities K-7500, KU-7500, FU-7500, FAC-7500, SA-7500 and FCSC-7500 refer to Chapter 3.

Overview - $75000 \leq F_{INIT} < 100000$



$7500 \leq F_{INIT} < 10000$

CU 7500		Page 2.9/2
X 9500		Page 2.9/4
TX 9500		Page 2.9/6
TU 7500	 	Page 2.9/8
TUS 7500		Page 2.9/10
LCF 7500		Page 2.9/12

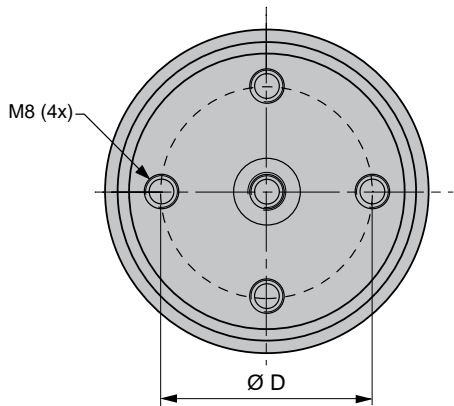
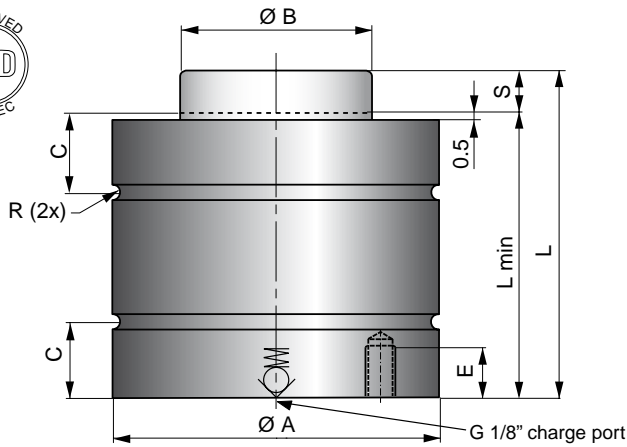

The CU gas spring is a very compact Bore Sealed gas spring, that gives a high force in a limited space. The max. frequency for the spring is 100 strokes/minute.

Springs with stroke lengths over 25 mm should always be attached to the tool, using a flange or the tapped holes in the bottom of the spring. We also recommend shorter stroke springs to be fastened for optimal service-life.

As an option, the CU springs can be delivered with a Side-Port plate (SP) for applications where a side-port is needed (i.e. for use in hose systems).

Volvo Part No.	Order No.	S Stroke	Force in N at 150 bar/+20°C		L ±0.25	L min	Ø A ±0.1	Ø B	C	Ø D	E	R	Gas vol. (l)	Weight (kg)
			Initial	End force**										
3051119	CU 7500-010	10	75000	104000	90	80	95.2	55	21	52	9	1.5	0.18	2.86
3051120	CU 7500-016	16		104000	116	100							0.30	3.22
3051121	CU 7500-025	25		109000	145	120							0.41	3.61
3054648	CU 7500-032	32*		105000	182	150							0.57	4.14
3054649	CU 7500-040	40*		107000	210	170							0.68	4.52
3054650	CU 7500-050	50*		106000	255	205							0.87	5.15

* = Should always be attached to the tool using the tapped holes in the bottom or a flange

** = at full stroke

Basic Information

For general information see "About gas springs", 2.1
 Pressure medium..... Nitrogen
 Max. charging pressure..... 150 bar (at 20°C)
 Min. charging pressure..... 25 bar (at 20°C)
 Operating temperature 0 to +80°C
 Force increase by temperature ±0.3%/°C
 Recommended max strokes/min ~80 to 100 (at 20° C)
 Max piston rod velocity 0.5 m/s

Rod surface..... Nitrided
 Tube surface Nitrided
 Repair kit 2014493
 Repair kit. Volvo Part No 3040233

Mounting Possibilities

Drop-In

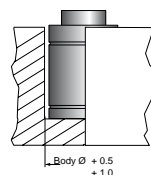

Top Mount FK

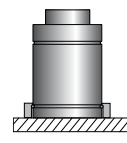
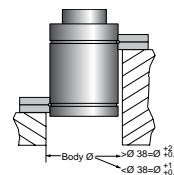

Foot Mount BFP

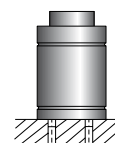

Base Mount B



Side Port SP

FK

Volvo Part No.	For model	Order No.	Ø a	Ø b	c	Ø d	e	f
3051123	CU 7500	FK-3000	130	110	92	13.5	18	30

Note! For spring of earlier version with R=2.5 FCS 1500 respective FCS 3000 should be used.

Please contact your local distributor for more information.

BFP

For model	Order No.	a	b	Ø c	d
CU 7500	BFP-7500	110	92	13	27.5

Note! BF flange for earlier version with R=2.5 is obsolete. Please contact your local distributor for more information.

SP 7500

It is also possible to order Side Port kit for attachment to old springs.

For model	Order No.	For U-groove mounts on SP
CU 7500	SP-7500	Refer to TU 3000

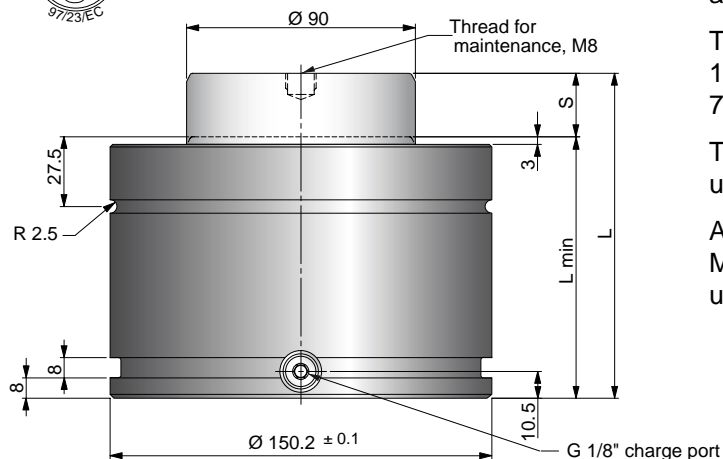

The Power Line series are our shortest and most powerful Piston Rod Sealed gas springs, giving you a great deal of force in a very small amount of space.

These gas springs are available with forces from 1700 N up to 200000 N and stroke lengths between 7 and 125 mm.

There is a side port for gas charging that can also be used to connect to a hose system.

An upper C-groove, lower U-groove together with four M10 threaded holes allow various mounting possibilities using our standard mounts.

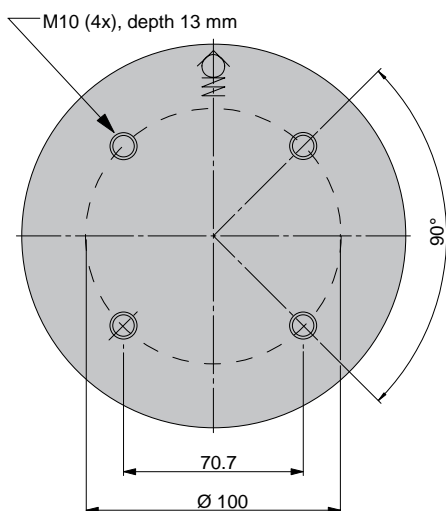

Volvo Part No.	Order No.	S Stroke	Force in N at 150 bar/+20°C		L ±0.25	L min	Gas vol. (l)	Weight (kg)
			Initial	End force*				
3053985	X 9500-019	19	95000	135000	116	97	0.49	9.86
3053986	X 9500-025	25		139000	128	103	0.58	10.23
3053987	X 9500-032	32		142000	142	110	0.70	10.67
3053988	X 9500-038	38		143000	154	116	0.80	11.04
3053989	X 9500-050	50		146000	178	128	0.99	11.79
3053990	X 9500-063	63		148000	204	141	1.20	12.05
3053991	X 9500-075	75		149000	228	153	1.39	12.28
3053992	X 9500-080	80		150000	238	158	1.47	12.38
3053993	X 9500-100	100		151000	278	178	1.79	12.78
3053994	X 9500-125	125		152000	328	203	2.20	13.27

* = at full stroke

Basic Information

- For general information see "About gas springs", 2.1
- Pressure medium Nitrogen
- Max. charging pressure 150 bar (at 20°C)
- Min. charging pressure 25 bar (at 20°C)
- Operating temperature 0 to +80°C
- Force increase by temperature ±0.3%/°C
- Recommended max strokes/min ... ~ 30 to 100 (at 20°C)
- Max piston rod velocity 1.6 m/s

- Rod surface Nitrided
- Tube surface Black oxide
- Repair kit 3020614
- Repair kit, Volvo Part No 3054853

Mounting Possibilities

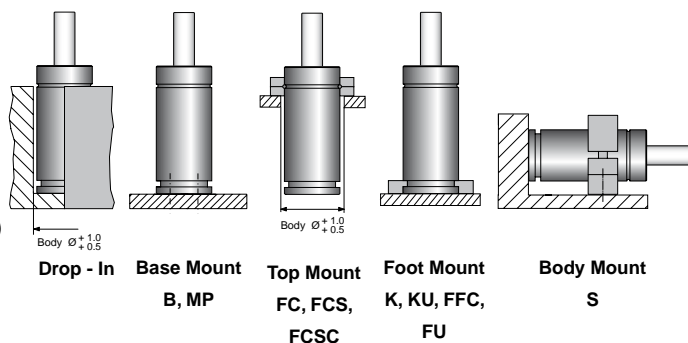

Note! For dimensions on mounting possibilities K-7500, KU-7500, FU-7500 and FCSC-7500 refer to Chapter 3.

MP

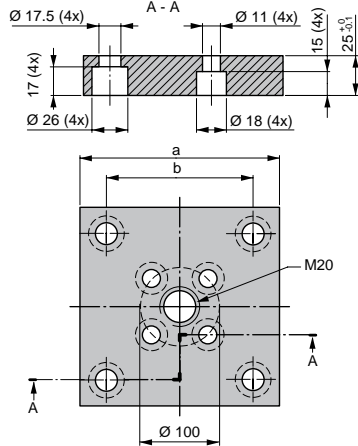

Note! Comes complete with screws to mount gas spring.

Order No.	a	b
MP-7500	190	138

FC

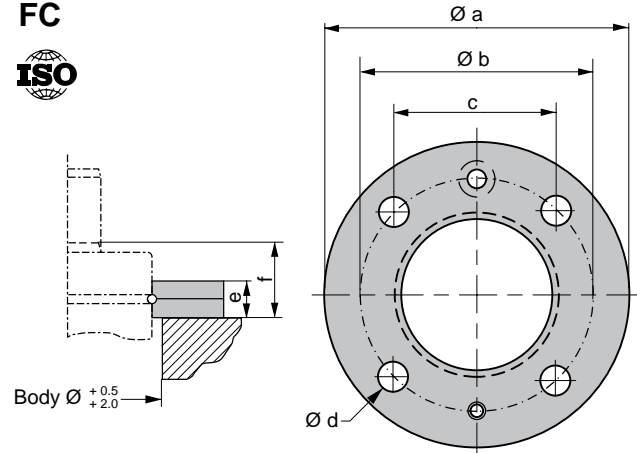

Order No.	Ø a	Ø b	c	Ø d	e	f
FC-7500	220	195	138	17.5	27	41

FCS

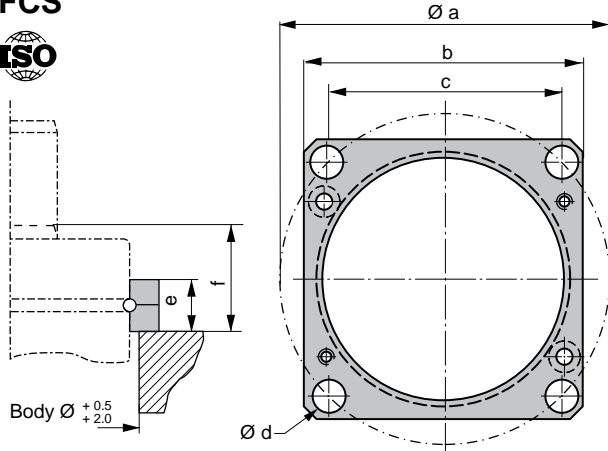

Volvo Part No.	Order No.	Ø a	b	c	Ø d	e	f
3044693	FCS-7500	195	162	138	17.5	27	41

FFC

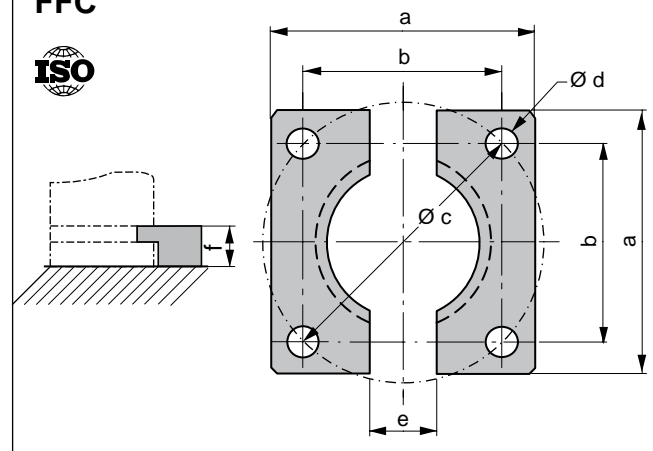

Volvo Part No.	Order No.	a	b	Ø c	Ø d	e	f
3054004	FFC-7500	190	138	195.2	17.5	24	12

S



Note! Support S is designed to be used in combination with flanges mounted in the U or C groove or mounting option B.

The mounting screw (M12) should be tightened with torque 91 Nm.

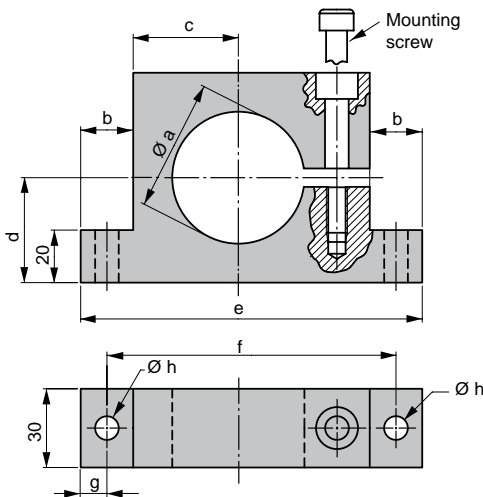

Volvo Part No.	Order No.	Ø a	b	c	d	e	f	g	Ø h
3044225	S-7500	150.4	30	95	100	260	230	15	13

Note! For dimensions on mounting possibilities K-7500, KU-7500, FU-7500 and FCSC-7500 refer to Chapter 3.

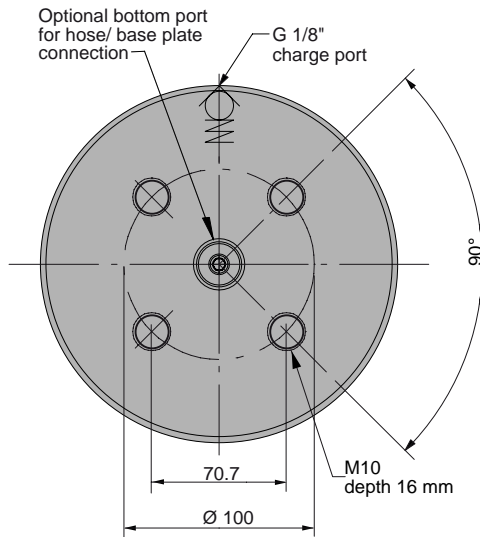
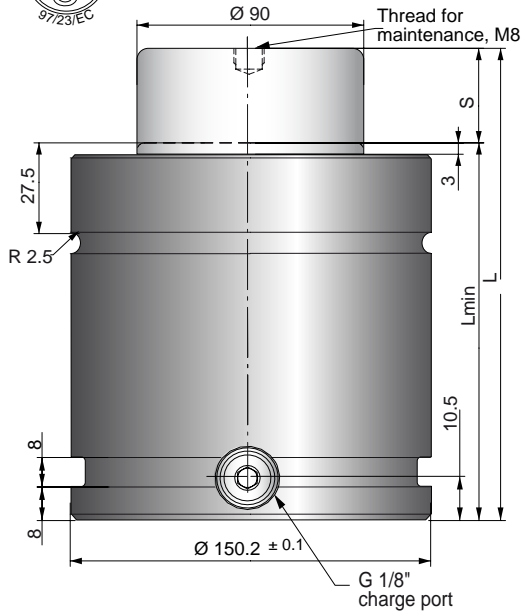

The Power Line - Heavy Duty series is a crossover between the standard TU series and Power Line X series.

These gas springs are available with forces from 9200 N up to 95000 N and stroke lengths between 13 and 300 mm.

There is a optional bottom port for hose/base plate connection.

An upper C-groove, lower U-groove and bottom threaded holes allow various mounting possibilities using our standard mounts.

Volvo Part No.	Order No.	S Stroke	Force in N at 150 bar/+20°C		L ±0.25	L min	Gas vol. (l)	Weight (kg)
			Initial	End force*				
3054718	TX 9500-025	25	95000	113185	205	180	1.09	16.86
3054719	TX 9500-038	38		119027	231	193	1.30	17.70
3054720	TX 9500-050	50		123252	255	205	1.49	18.48
3054721	TX 9500-063	63		126937	281	218	1.69	19.32
	TX 9500-075	75		129734	305	230	1.88	20.10
3054722	TX 9500-080	80		130762	315	235	1.96	20.42
3054723	TX 9500-100	100		134256	355	255	2.28	31.72
3054724	TX 9500-125	125		137591	405	280	2.67	23.35
	TX 9500-150	150		140152	455	305	3.07	24.97
3054725	TX 9500-160	160		141017	475	315	3.23	25.62
	TX 9500-175	175		142180	505	330	3.47	26.59
	TX 6600-200	200		143826	555	355	3.86	28.21
3054726	TX 6600-250	250		146336	655	405	4.65	31.46
	TX 6600-300	300		148158	755	455	5.44	34.70

* = at full stroke

Basic Information

- For general information see "About gas springs", 2.1
- Pressure medium Nitrogen
- Max. charging pressure 150 bar (at 20°C)
- Min. charging pressure 25 bar (at 20°C)
- Operating temperature 0 to +80°C
- Force increase by temperature ±0.3%/°C
- Recommended max strokes/min ... ~ 30 to 100 (at 20°C)
- Max piston rod velocity 1.6 m/s

- Rod surface Nitrided
- Tube surface Black oxide
- Repair kit 3022901
- Repair kit. Volvo Part No 3054854

Mounting Possibilities

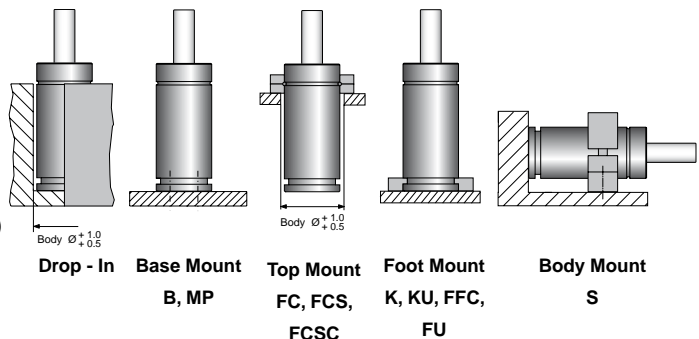

Note! For dimensions on mounting possibilities K-7500, KU-7500, FU-7500 and FCSC-7500 refer to Chapter 3.

MP

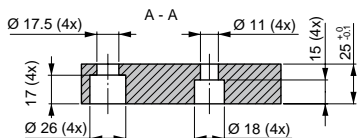

Note! Comes complete with screws to mount gas spring.

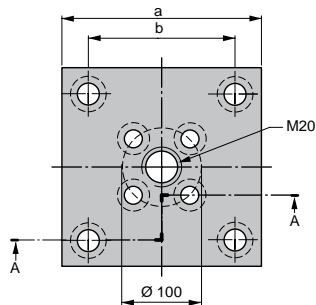

Order No.	a	b
MP-7500	190	138

FC

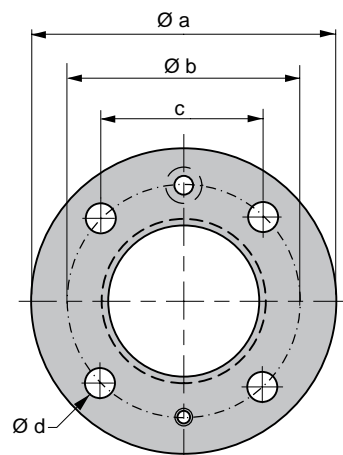
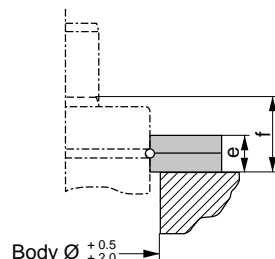

Order No.	Ø a	Ø b	c	Ø d	e	f
FC-7500	220	195	138	17.5	27	41

FCS

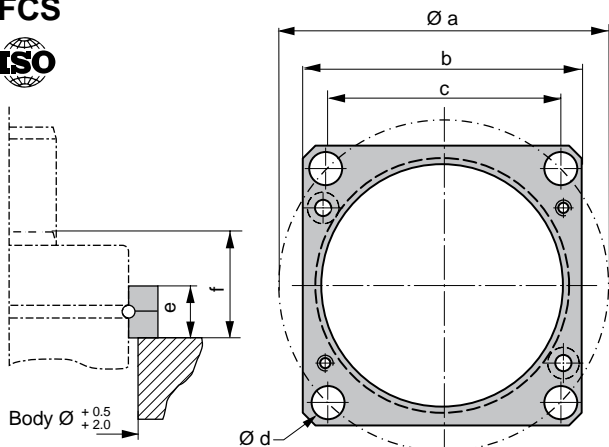

Volvo Part No.	Order No.	Ø a	b	c	Ø d	e	f
3044693	FCS-7500	195	162	138	17.5	27	41

FFC

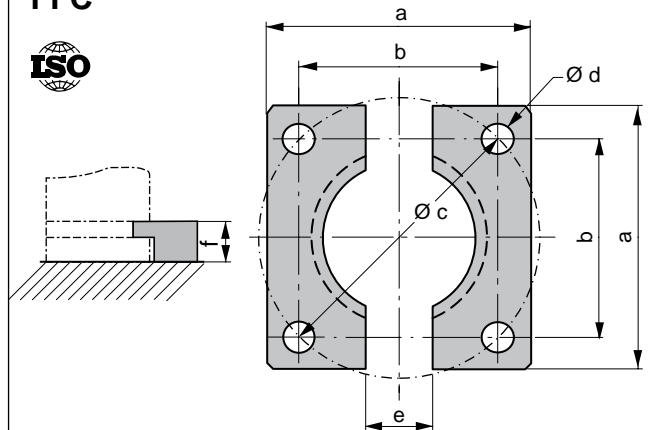

Volvo Part No.	Order No.	a	b	Ø c	Ø d	e	f
3054004	FFC-7500	190	138	195.2	17.5	24	12

S



Note! Support S is designed to be used in combination with flanges mounted in the U or C groove or mounting option B.

The mounting screw (M12) should be tightened with torque 91 Nm.

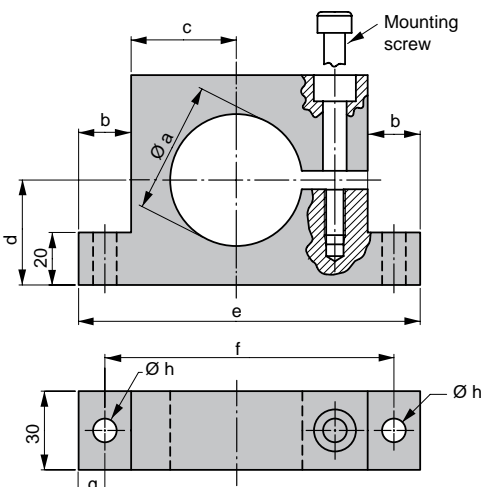

Volvo Part No.	Order No.	Ø a	b	c	d	e	f	g	Ø h
3044225	S-7500	150.4	30	95	100	260	230	15	13

Note! For dimensions on mounting possibilities K-7500, KU-7500, FU-7500 and FCSC-7500 refer to Chapter 3.

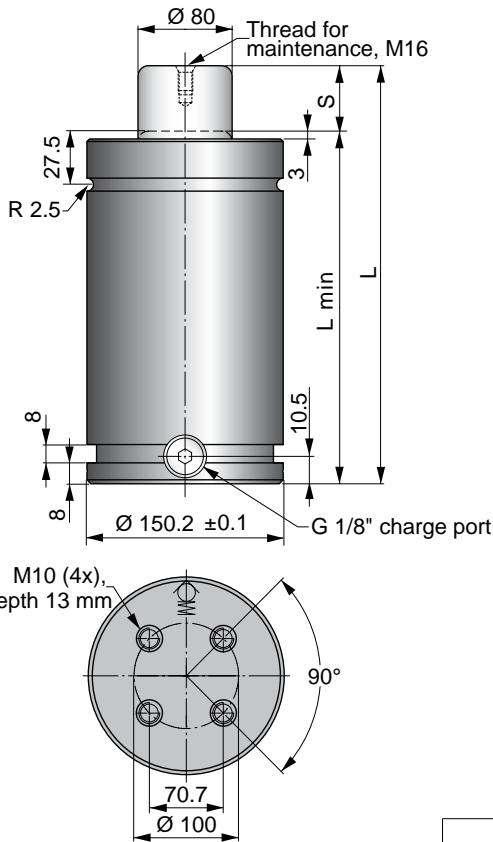

The standard line of gas springs is the TU line. Sizes 250 to 10000 correspond to the ISO 11901 standard for gas springs.

Sizes 750 to 7500 correspond to FORD's, GM's and Renault's automotive gas spring standards. When ordering a Renault standard gas spring add an R to the Order No. (for example: TUR 7500-xxx).

TUR will be replaced by TUS

9

Being phased out!

TU, TUR och LCF 7500 gas springs are also available with double charging ports. When ordering this type, add a D to the Order No.

For example: TUD 7500-xxx

TUD 7500 example

Note! TUD, TUDR and LCFD 7500 gas springs have two valves and are delivered charged.

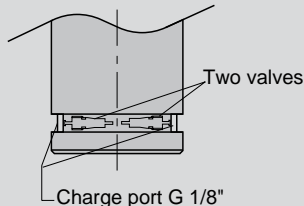

TUR will be replaced by TUS

Volvo Part No.	Order No.	S Stroke	Force in N at 150 bar/+20°C		L ±0.25	L min	Gas vol. (l)	Weight (kg)	ISO
			Initial	End Force*					
3044193	TU 7500-025	25	75000	105000	205	180	0.51	20.30	✓
3044194	TU 7500-038	38.1		110000	231.2	193.1	0.67	21.40	
3044195	TU 7500-050	50		113000	255	205	0.81	22.40	✓
3044196	TU 7500-064	63.5		115000	282	218.5	0.98	23.50	
3044197	TU 7500-080	80		117000	315	235	1.18	24.80	✓
3044198	TU 7500-100	100		119000	355	255	1.43	26.50	✓
3044199	TU 7500-125	125		121000	405	280	1.74	28.50	✓
3044200	TU 7500-160	160		122000	475	315	2.17	31.40	✓
	TU 7500-200	200		123000	555	355	2.66	34.70	
	TU 7500-250	250		124000	655	405	3.27	38.80	
	TU 7500-300	300		124000	755	455	3.88	42.90	

* = at full stroke

Basic Information

- For general information see "About gas springs", 2.1
- Pressure medium Nitrogen
- Max. charging pressure 150 bar
- Min. charging pressure..... 25 bar
- Operating temperature 0 to +80°C
- Force increase by temperature ±0.3%/°C
- Recommended max strokes/min ~ 15-40 (at 20°C)
- Max piston rod velocity 1.6 m/s
- Rod surface..... Nitrided
- Tube surface Black oxide
- Repair kits
- * TU 7500 new version 3018877
- Repair kit. Volvo Part No 3050722 TU 7500 old version..... 2014068-09
- Repair kit. Volvo Part No 3044227
- *New version is identified by circular rings on the top of tube, guide and rod.

Mounting Possibilities

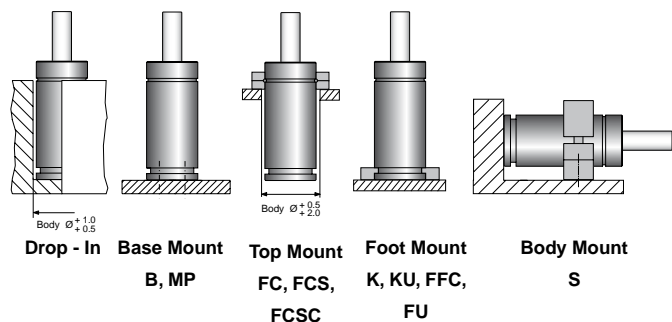

Note! For dimensions on mounting possibilities K-7500, KU-7500, FU-7500 and FCSC-7500 refer to Chapter 3.

MP

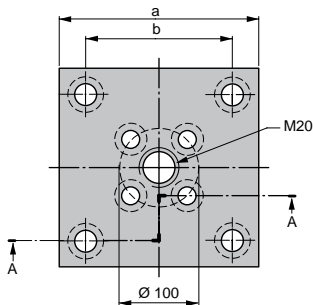
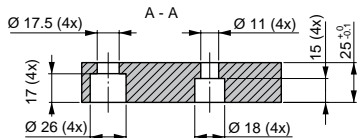

Note! Comes complete with screws to mount gas spring.

Order No.	a	b
MP-7500	190	138

FC

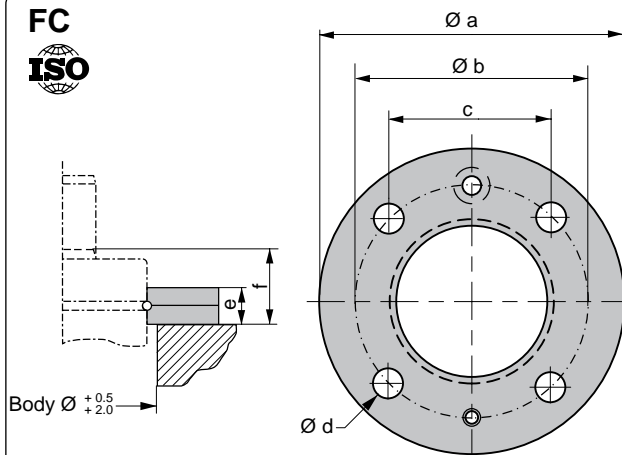

Order No.	Ø a	Ø b	c	Ø d	e	f
FC-7500	220	195	138	17.5	27	41

FCS

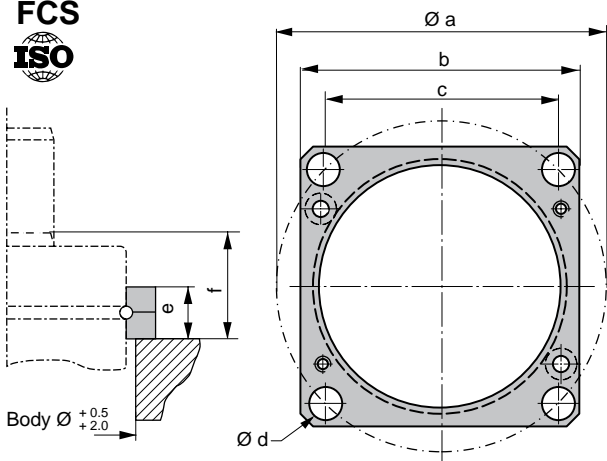

Volvo Par No.	Order No.	Ø a	b	c	Ø d	e	f
3044693	FCS-7500	195	162	138	17.5	27	41

FFC

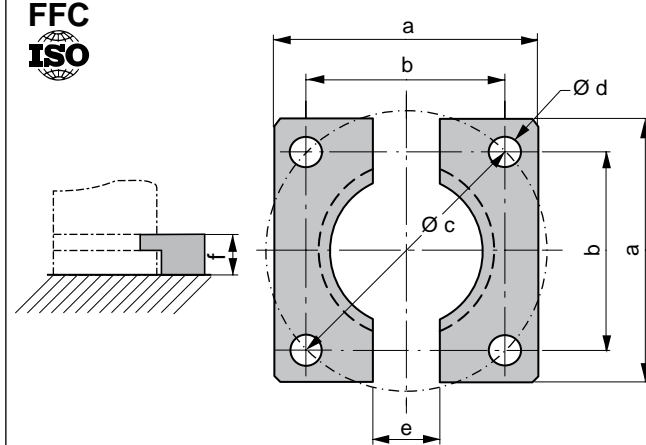

Volvo Part No.	Order No.	a	b	Ø c	Ø d	e	f
3054004	FFC-7500	190	138	195.2	17.5	24	12

S



Note! Support S is designed to be used in combination with flanges mounted in the U or C groove or mounting option B.

The mounting screw (M12) should be tightened with torque 91 Nm.

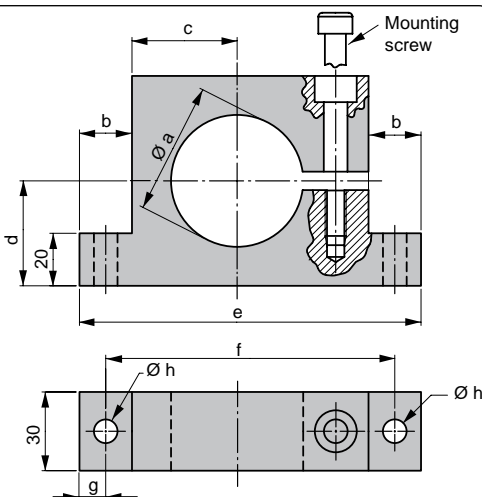

Volvo Part No.	Order No.	Ø a	b	c	d	e	f	g	Ø h
3044225	S-7500	150.4	30	95	100	260	230	15	13

Note! For dimensions on mounting possibilities K-7500, KU-7500, FU-7500 and FCSC-7500 refer to Chapter 3.

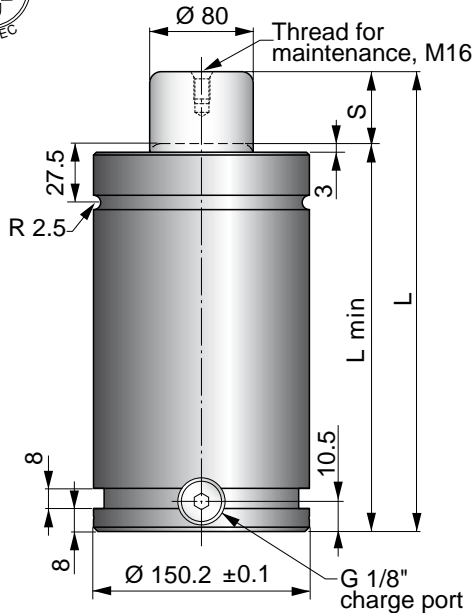

The High Speed gas springs (TUS) are engineered to withstand press stroke speeds to a maximum 2 m/s, which meet the safety demands from the French automotive manufacturer Renault.

These gas springs are available in sizes 750 to 7500 and dimensions correspond to the ISO 11901 standard for gas springs.

TUS gas spring will replace TUR that is being phased out.

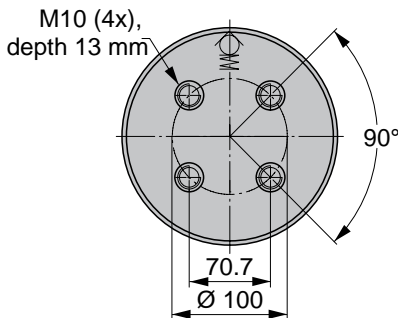

Order No.	S Stroke	Force in N at 150 bar/+20°C		L ±0.25	L min	Gas vol. (l)	Weight (kg)
		Initial	End Force*				
TUS 7500-025	25	75000	105000	205	180	0.51	19.40
TUS 7500-038	38.1		110000	231.2	193.1	0.67	20.47
TUS 7500-050	50		113000	255	205	0.81	21.25
TUS 7500-064	63.5		115000	282	218.5	0.98	22.56
TUS 7500-080	80		117000	315	235	1.18	23.91
TUS 7500-100	100		119000	355	255	1.43	25.56
TUS 7500-125	125		121000	405	280	1.74	27.61
TUS 7500-160	160		122000	475	315	2.17	30.48
TUS 7500-200	200		123000	555	355	2.66	33.76
TUS 7500-250	250		124000	655	405	3.27	37.87
TUS 7500-300	300	124000	755	455	3.88	41.97	

* = at full stroke

Basic Information

For general information see "About gas springs", 2.1
 Pressure medium Nitrogen
 Max. charging pressure 150 bar
 Min. charging pressure 25 bar
 Operating temperature 0 to +80°C
 Force increase by temperature ±0.3%/°C
 Recommended max strokes/min ~ 15-40 (at 20°C)
 Max piston rod velocity 2 m/s

Rod surface Nitrided
 Tube surface Black oxide
 Repair kit 3019281

Mounting Possibilities

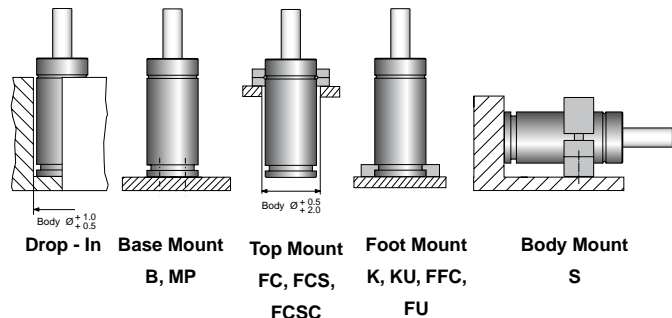

Note! For dimensions on mounting possibilities K-7500, KU-7500, FU-7500 and FCSC-7500 refer to Chapter 3.

MP
ISO

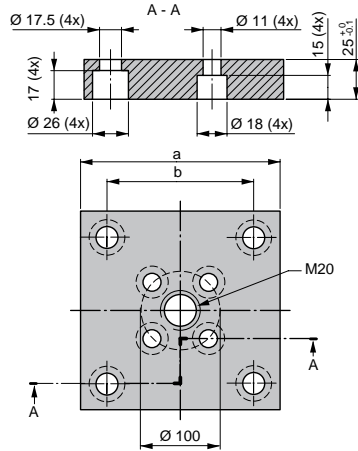

Note! Comes complete with screws to mount gas spring.

Order No.	a	b
MP-7500	190	138

FC
ISO

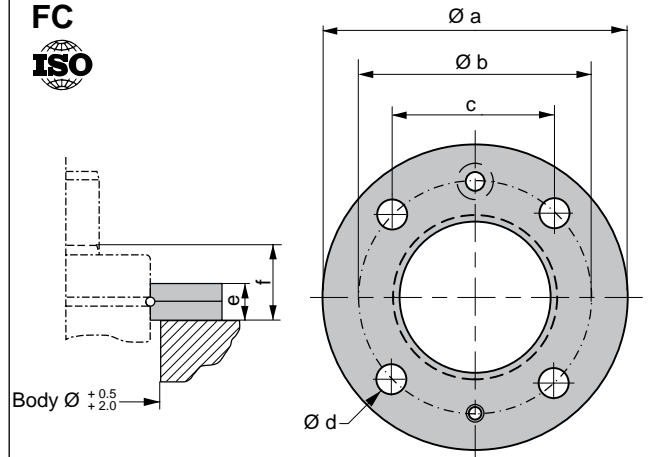

Order No.	Ø a	Ø b	c	Ø d	e	f
FC-7500	220	195	138	17.5	27	41

FCS
ISO

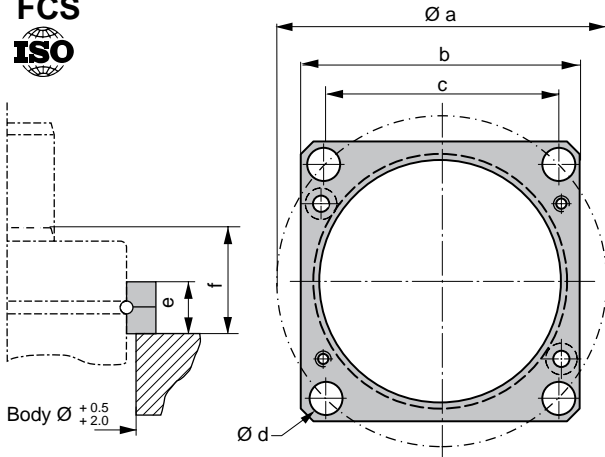

Order No.	Ø a	b	c	Ø d	e	f
FCS-7500	195	162	138	17.5	27	41

FFC
ISO

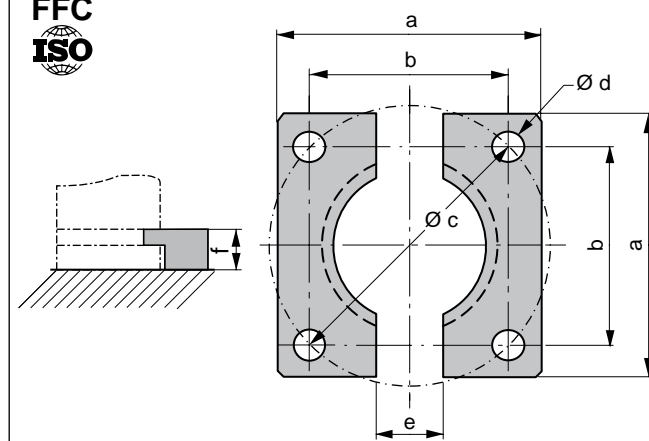

Order No.	a	b	Ø c	Ø d	e	f
FFC-7500	190	138	195.2	17.5	24	12

S
ISO

Note! Support S is designed to be used in combination with flanges mounted in the U or C groove or mounting option B.

The mounting screw (M12) should be tightened with torque 91 Nm.

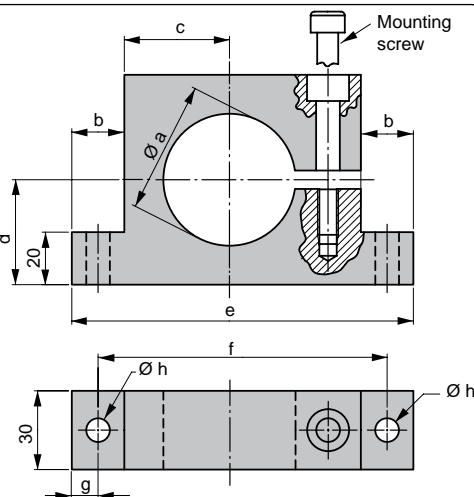

Order No.	Ø a	b	c	d	e	f	g	Ø h
S-7500	150.4	30	95	100	260	230	15	13

Note! For dimensions on mounting possibilities K-7500, KU-7500, FU-7500 and FCSC-7500 refer to Chapter 3.

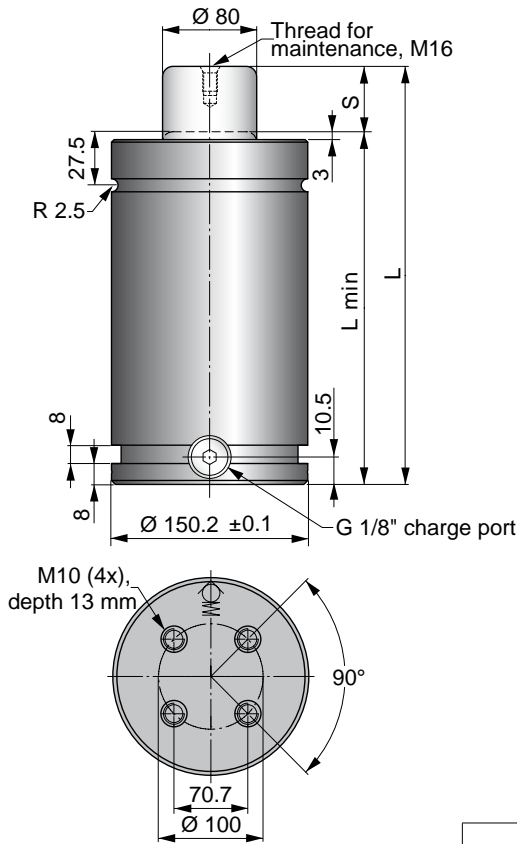

Low Contact Force (LCF) gas springs are designed to reduce excessive shock loads, high noise levels and extreme pad bounce, all factors that lead to high press maintenance costs and noise pollution.

Force vs Stroke for LCF 7500 Springs

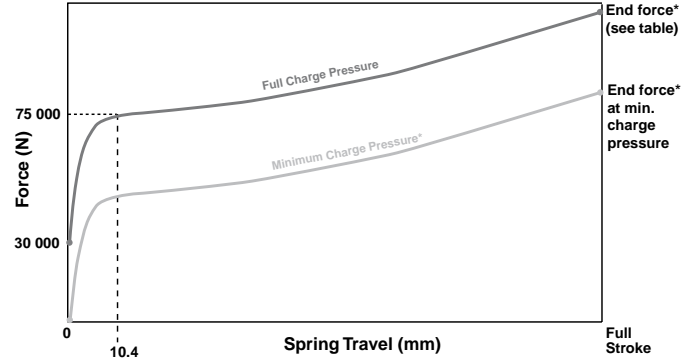

9

Being phased out!

TU, TUR och LCF 7500 gas springs are also available with double charging ports. When ordering this type, add a D to the Order No. For example:
LCFD 7500-xxx LCFD 7500 example

Note! TUD, TURD and LCFD 7500 gas springs have two valves and are delivered charged.

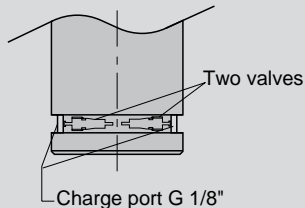

Volvo Part No.	Order No.	S Stroke	Force in N at 150 bar/+20°C		L ±0.25	L min	Gas vol. (l)	Weight (kg)
			Initial	End Force*				
	LCF 7500-025	25	75000	105000	205	180	0.51	19.40
	LCF 7500-038	38.1		110000	231.2	193.1	0.67	20.47
	LCF 7500-050	50		113000	255	205	0.81	21.25
	LCF 7500-064	63.5		115000	282	218.5	0.98	22.56
	LCF 7500-080	80		117000	315	235	1.18	23.91
	LCF 7500-100	100		119000	355	255	1.43	25.56
	LCF 7500-125	125		121000	405	280	1.74	27.61
	LCF 7500-160	160		122000	475	315	2.17	30.48
	LCF 7500-200	200		123000	555	355	2.66	33.76
	LCF 7500-250	250		124000	655	405	3.27	37.87
	LCF 7500-300	300	124000	755	455	3.88	41.97	

* = at full stroke

Basic Information

Mounting Possibilities

- For general information see "About gas springs", 2.1
- Pressure medium Nitrogen
- Max. charging pressure 150 bar
- Min. charging pressure 89 bar
- Operating temperature 0 to +80°C
- Force increase by temperature ±0.3%/°C
- Recommended max strokes/min ~ 15-40 (at 20°C)
- Max piston rod velocity 1.6 m/s
- Rod surface..... Nitrided
- Tube surface Black oxide

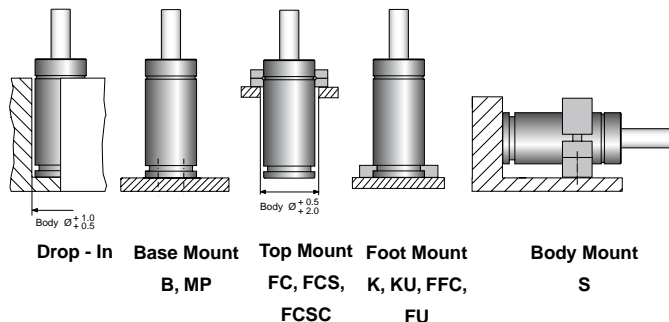

Note! For dimensions on mounting possibilities K-7500, KU-7500, FU-7500 and FCSC-7500 refer to Chapter 3.

- Repair kits
- * LC 7500 new version..... 3019381
- LCF 7500 old version..... 3019134
- *New version is identified by circular rings on the top of tube, guide and rod.

MP

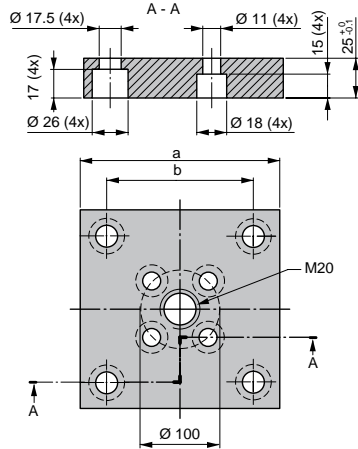

Note! Comes complete with screws to mount gas spring.

Order No.	a	b
MP-7500	190	138

FC

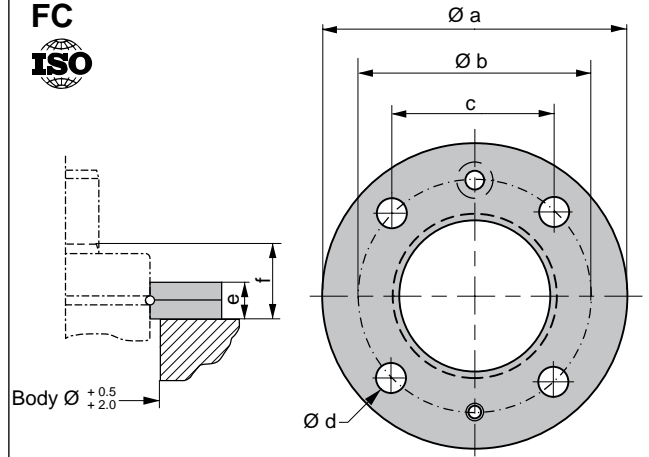

Order No.	Ø a	Ø b	c	Ø d	e	f
FC-7500	220	195	138	17.5	27	41

FCS

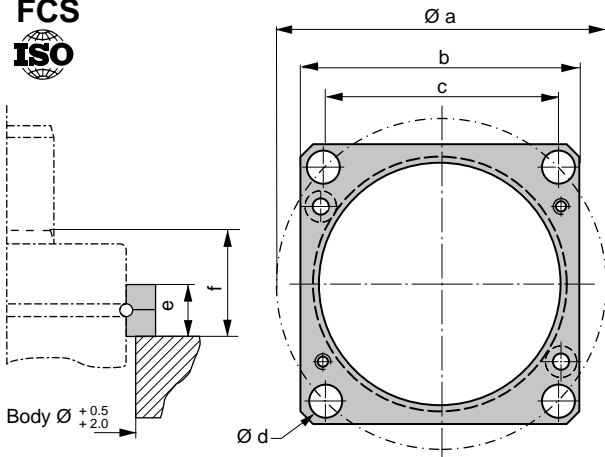

Volvo Par No.	Order No.	Ø a	b	c	Ø d	e	f
3044693	FCS-7500	195	162	138	17.5	27	41

FFC

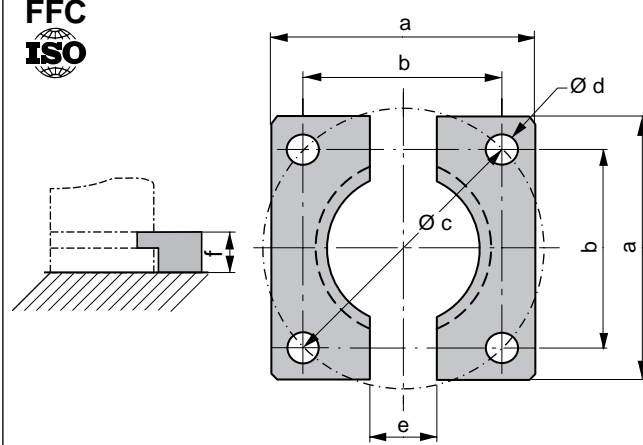

Volvo Part No.	Order No.	a	b	Ø c	Ø d	e	f
3054004	FFC-7500	190	138	195.2	17.5	24	12

S

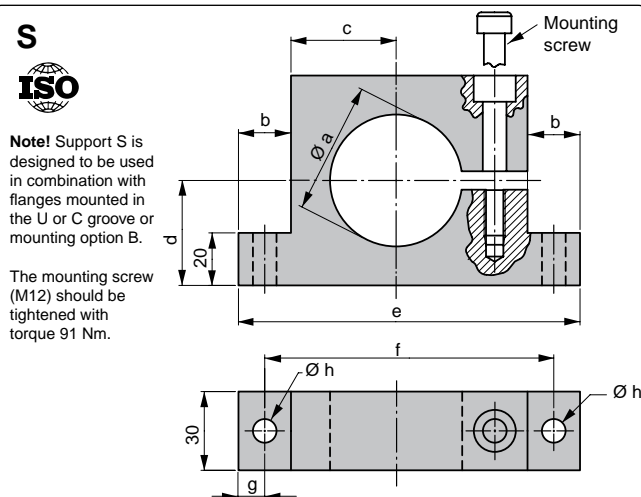

Note! Support S is designed to be used in combination with flanges mounted in the U or C groove or mounting option B.

The mounting screw (M12) should be tightened with torque 91 Nm.

Volvo Part No.	Order No.	Ø a	b	c	d	e	f	g	Ø h
3044225	S-7500	150.4	30	95	100	260	230	15	13

Note! For dimensions on mounting possibilities K-7500, KU-7500, FU-7500 and FCSC-7500 refer to Chapter 3.

Overview - $F_{INIT} \geq 100000$

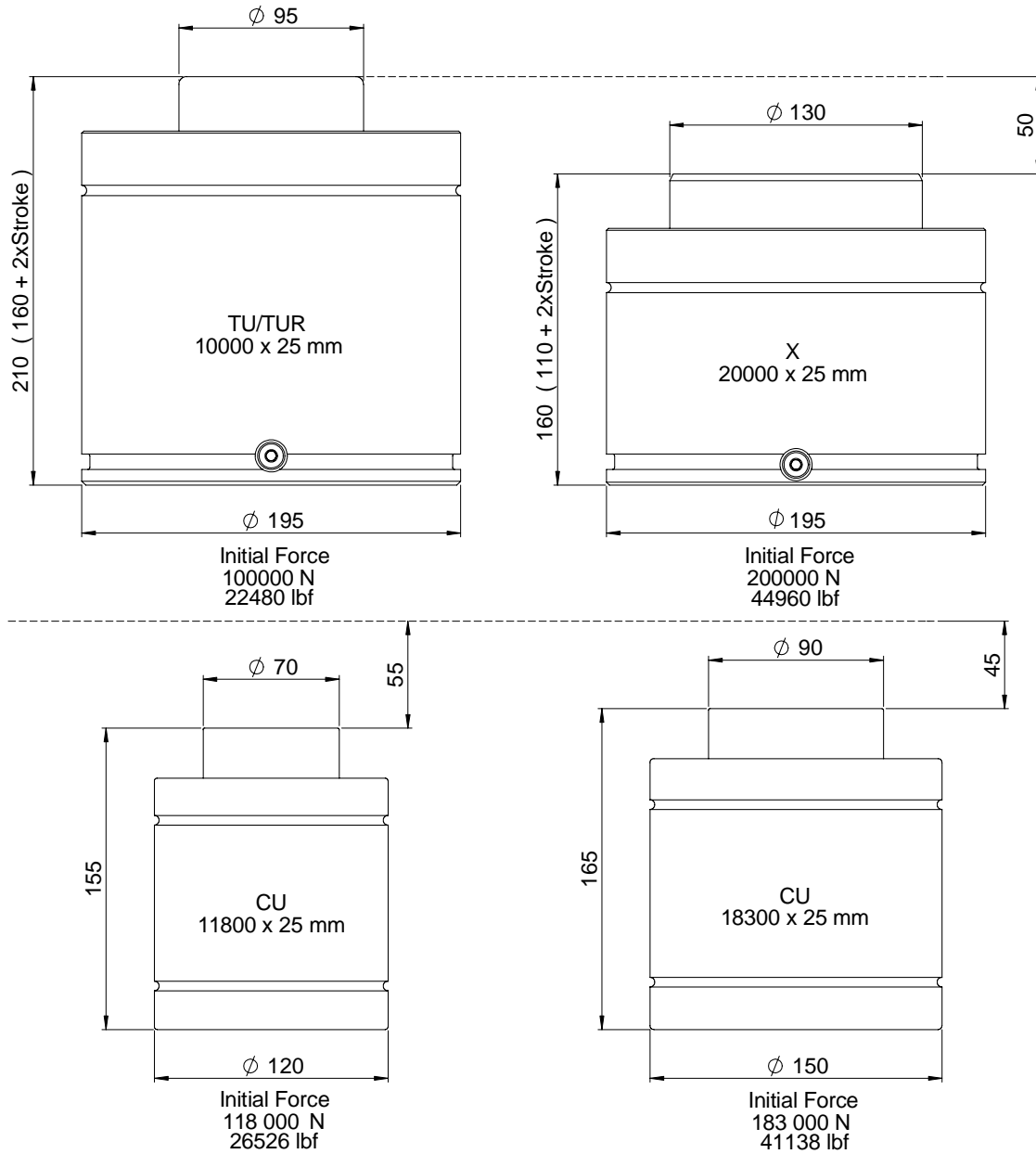

$F_{INIT} \geq 100000$

CU 11800 - 18300		Page 2.10/2
TU 10000	 	Page 2.10/4
X 20000		Page 2.10/6

CU 11800 - 18300

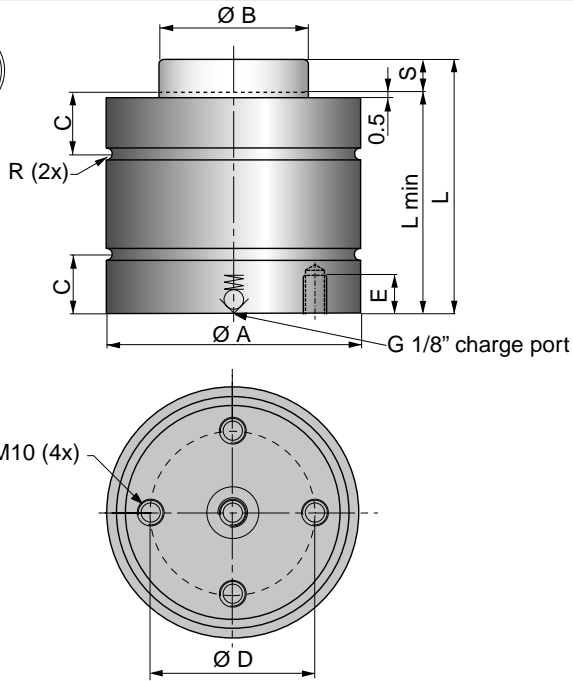

The CU gas spring is a very compact Bore Sealed gas spring, that gives a high force in a limited space. The max. frequency for the spring is 100 strokes/minute.

Springs with stroke lengths over 25 mm should always be attached to the tool, using a flange or the tapped holes in the bottom of the spring. We also recommend shorter stroke springs to be fastened for optimal service-life.

As an option, the CU springs can be delivered with a Side-Port plate (SP) for applications where a side-port is needed (i.e. for use in hose systems).

Volvo part No.	Order No.	S Stroke	Force in N at 150 bar/+20°C		L ±0.25	L min	Ø A ±0.1	Ø B	C	Ø D	E	R	Gas vol. (l)	Weight (kg)
			Initial	End force**										
3044667	CU 11800-010	10	118000	155000	100	90	120.2	70	22.5	68	11	2.5	0.33	4.95
3044668	CU 11800-016	16		158000	126	110							0.50	5.55
3044669	CU 11800-025	25		170000	155	130							0.68	6.17
054651	CU 11800-032	32*		164000	187	155							0.88	6.90
054652	CU 11800-040	40*		165000	220	180							1.00	7.65
054653	CU 11800-050	50*		166000	260	210							1.35	8.55
3044670	CU 18300-010	10	183000	235000	110	100	150.2	90	24.5	90	11	2.5	0.56	8.78
3044671	CU 18300-016	16		252000	136	120							0.84	9.72
3044672	CU 18300-025	25		254000	165	140							1.13	10.71
3054654	CU 18300-032	32*		251000	197	165							1.45	11.88
3054655	CU 18300-040	40*		250000	235	195							1.86	13.28
3054656	CU 18300-050	50*		255000	270	220							2.19	14.50

* = Should always be attached to the tool using the tapped holes in the bottom or a flange

** = at full stroke

Basic Information

- For general information see "About gas springs", 2.1
- Pressure medium..... Nitrogen
- Max. charging pressure..... 150 bar (at 20°C)
- Min. charging pressure..... 25 bar (at 20°C)
- Operating temperature 0 to +80°C
- Force increase by temperature ±0.3%/°C
- Recommended max strokes/min ~80 to 100 (at 20° C)
- Max piston rod velocity 0.8 m/s
- Rod surface..... Nitrided
- Tube surface Nitrided
- Repair kit CU 11800 2014493
- Repair kit CU 11800 Volvo Part No. 3044677
- Repair kit CU 18300 2014493
- Repair kit CU 18300 Volvo Part No. 3044678

Mounting Possibilities

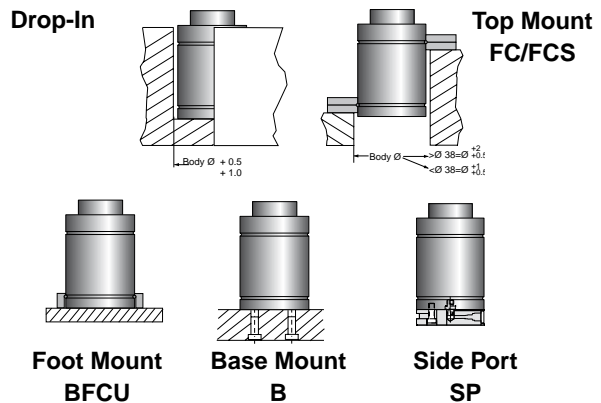

FC

For model	Order No.	Ø a	Ø b	c	Ø d	e	f
CU 11800	FC-5000	175	155	109.5	13.5	21	33
CU 18300	FC-7500	220	195	138	17.5	27	38

FCS

Volvo Part No.	For model	Order No.	Ø a	b	c	Ø d	e	f
3044692	CU 11800	FCS-5000	155	130	109.5	13.5	21	33
3044693	CU 18300	FCS-7500	195	162	138	17.5	27	38

BFCU

For model	Order No.	a	b	Ø c	d
CU 11800	BFCU-11800	130	109.5	13	29.5
CU 18300	BFCU-18300	162	138	17.5	34.5

SP 11800

It is also possible to order Side Port kit for attachment to old springs.

For model	Order No.	For U-groove mounts on SP
CU 11800	SP-11800	Refer to TU 5000

SP 18300

It is also possible to order Side Port kit for attachment to old springs.

For model	Order No.	For U-groove mounts on SP
CU 18300	SP-18300	Refer to TU 7500

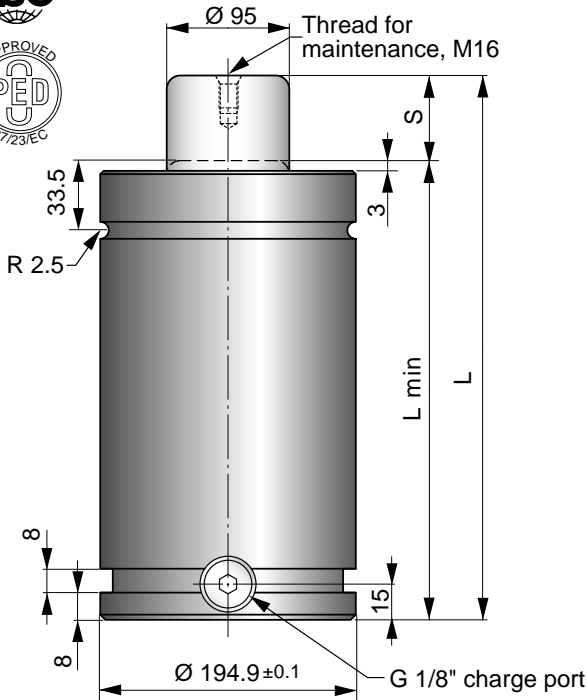

The standard line of gas springs is the TU line. Sizes 250 to 10000 correspond to the ISO 11901 standard for gas springs.

TU 10 000 is also available with double ports. When ordering this type add a **D** to the Order No. Example: TUD 10000-xxx.

Note! The TUD 10000 has two valves and is normally delivered charged.

Being phased out!

TUD 10000 example

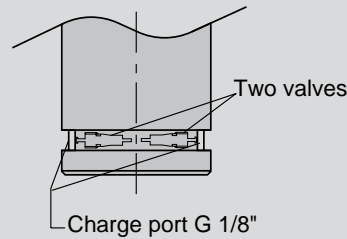

10

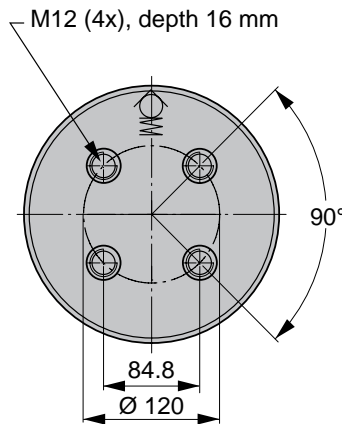

Volvo Part No.	Order No.	S Stroke	Force in N at 150 bar/+20°C		L ±0.25	L min	Gas vol. (l)	Weight (kg)	ISO
			Initial	End force**					
3053967	TU 10000-025	25	106000	138000	210	185	0.87	35.90	
3053968	TU 10000-038	38.1		143000	236.2	198.1	1.13	37.60	
3053969	TU 10000-050	50		147000	260	210	1.37	39.20	✓
3053970	TU 10000-064	63.5		150000	287	223.5	1.64	41.00	
3053971	TU 10000-080	80		152000	320	240	1.98	43.20	✓
3053972	TU 10000-100	100		156000	360	260	2.38	45.80	✓
3053973	TU 10000-125	125		157000	410	285	2.88	49.10	✓
3053974	TU 10000-160	160		158000	480	320	3.59	53.70	✓
	TU 10000-200	200		160000	560	360	4.39	59.00	✓
	TU 10000-250	250		160000	660	410	5.40	65.60	✓
	TU 10000-300	300	160000	760	460	6.40	72.20	✓	

** = at full stroke

Basic Information

Mounting Possibilities

- For general information see "About gas springs", 2.1
- Pressure medium Nitrogen
- Max. charging pressure 150 bar
- Min. charging pressure 25 bar
- Operating temperature 0 to +80°C
- Force increase by temperature ±0.3%/°C
- Recommended max strokes/min ... ~ 15-40 (at 20°C)
- Max piston rod velocity 1.6 m/s
- Rod surface..... Nitrided
- Tube surface Black oxide
- Repair kits 3019037
- Volvo Part No 3054855
- old version..... 2014068-10

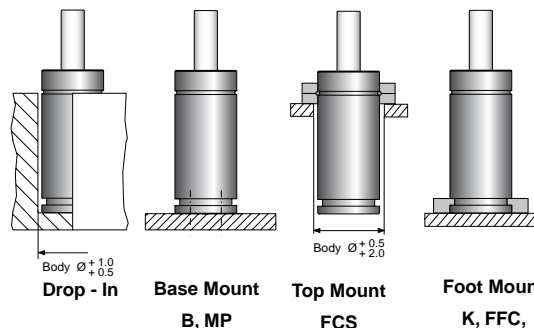

Note! For dimensions on mounting possibility K-10000 refer to Chapter 3.

MP
ISO

Note! Comes complete with screws to mount gas spring.

Order No.	a	b
MP-10000	210	170

FCS
ISO

Volvo Part No.	Order No.	Ø a	b	c	Ø d	e	f
3054006	FCS-10000	240.4	210	170	17.5	27	47

FFC
ISO

Volvo Part No.	Order No.	a	b	Ø c	Ø d	e	f
3054005	FFC-10000	210	170	240.4	17.5	24	13

Note! For dimensions on mounting possibility K-10000 refer to Chapter 3.

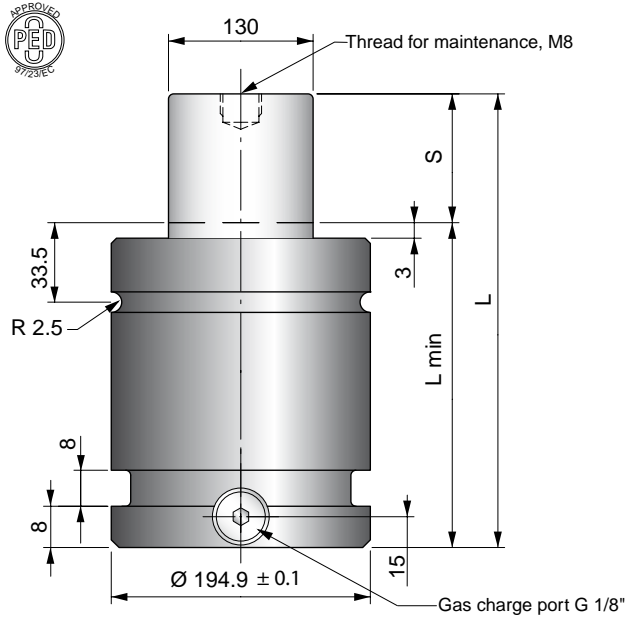

The Power Line series are our shortest and most powerful Piston Rod Sealed gas springs, giving you a great deal of force in a very small amount of space.

These gas springs are available with forces from 1700 N up to 200000 N and stroke lengths between 7 and 125 mm.

There is a side port for gas charging that can also be used to connect to a hose system.

An upper C-groove, lower U-groove together with four M12 threaded holes allow various mounting possibilities using our standard mounts.

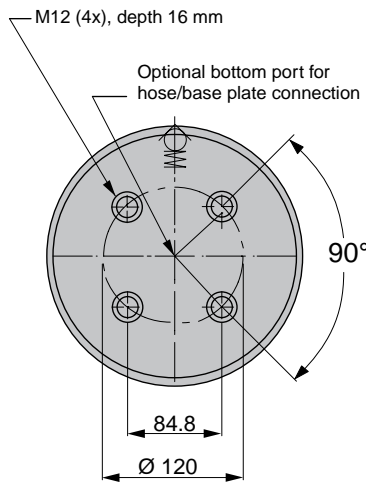

Volvo Part No.	Order No.	S Stroke	Force in N at 150 bar/+20°C		L ±0.25	L min	Gas vol. (l)	Weight (kg)
			Initial	End force*				
	X 20 000-019	19		259000	148	129	1.21	21.50
3054675	X 20 000-025	25		270000	160	135	1.38	22.16
	X 20 000-032	32		280000	174	142	1.59	22.92
3054676	X 20 000-038	38		287000	186	148	1.77	23.57
3054677	X 20 000-050	50		298000	210	160	2.12	24.87
3054678	X 20 000-063	63		307000	236	173	2.50	26.28
	X 20 000-075	75		313000	260	185	2.85	27.59
3054679	X 20 000-080	80		315000	270	190	3.00	28.13
3054680	X 20 000-100	100		323000	310	210	3.58	30.30
3054681	X 20 000-125	125		330000	360	235	4.31	33.02

* = at full stroke

Basic Information

- For general information see "About gas springs", 2.1
- Pressure medium Nitrogen
- Max. charging pressure 150 bar (at 20°C)
- Min. charging pressure 25 bar (at 20°C)
- Operating temperature 0 to +80°C
- Force increase by temperature ±0.3%/°C
- Recommended max strokes/min ... ~ 15 to 40 (at 20°C)
- Max piston rod velocity 1.6 m/s

- Rod surface Nitrided
- Tube surface Black oxide
- Repair kit 3022902
- Repair kit Volvo Part No 3054856

Mounting Possibilities

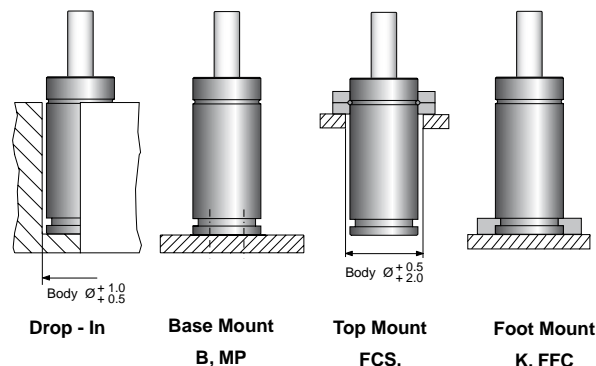

Note!
For dimensions on mounting possibility K-10000 refer to Chapter 3.

MP
ISO

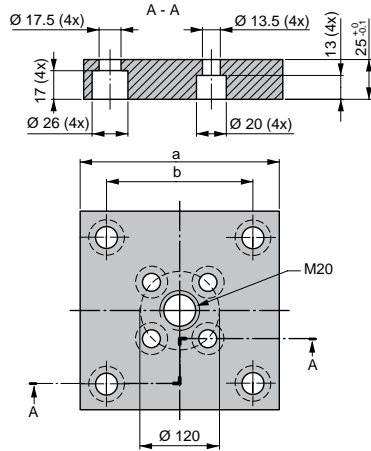

Note! Comes complete with screws to mount gas spring.

Order No.	a	b
MP-10000	210	170

FCS
ISO

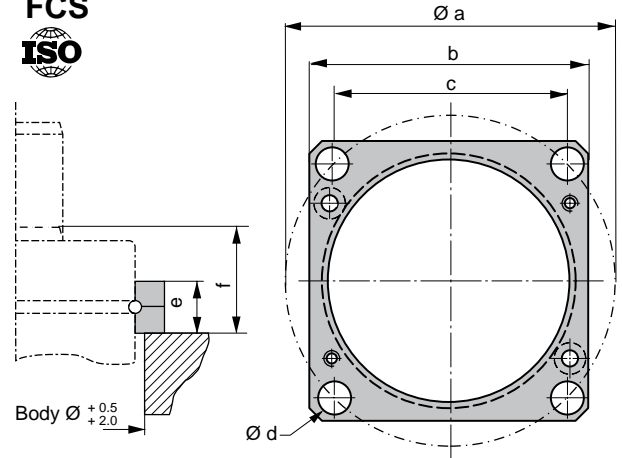

Volvo Part No.	Order No.	Ø a	b	c	Ø d	e	f
3054006	FCS-10000	240.4	210	170	17.5	27	47

FFC
ISO

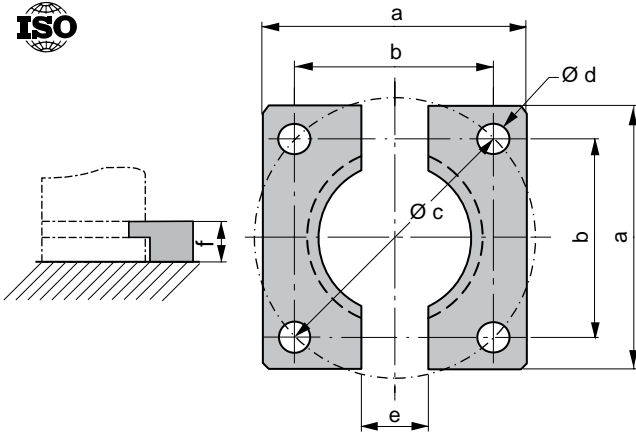

Volvo Part No.	Order No.	a	b	Ø c	Ø d	e	f
3054005	FFC-10000	210	170	240.4	17.5	24	13

Note! For dimensions on mounting possibility K-10000 refer to Chapter 3.

Overview - MT Models

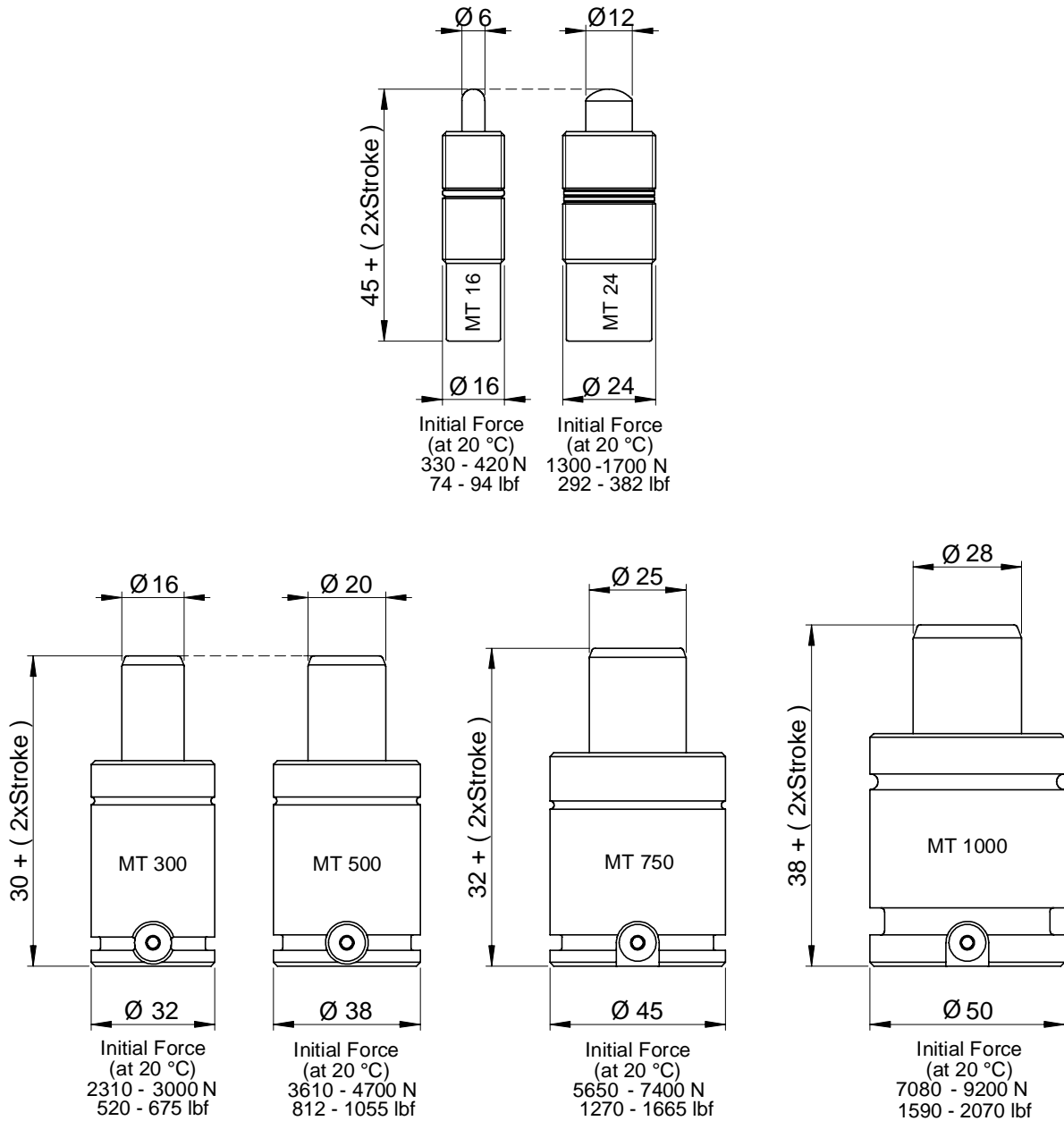

MT Charging Pressure	
Working Temperature	Charging Pressure
0 - (80) °C	150 bar
80 - (100) °C	125 bar
100 - 120 °C	115 bar

MT - Mould Temp Gas Springs

MT 16



Page 2.11/2

MT 24



Page 2.11/3

MT 300



Page 2.11/4

MT 500



Page 2.11/6

MT 750



Page 2.11/8

MT 1000



Page 2.11/10

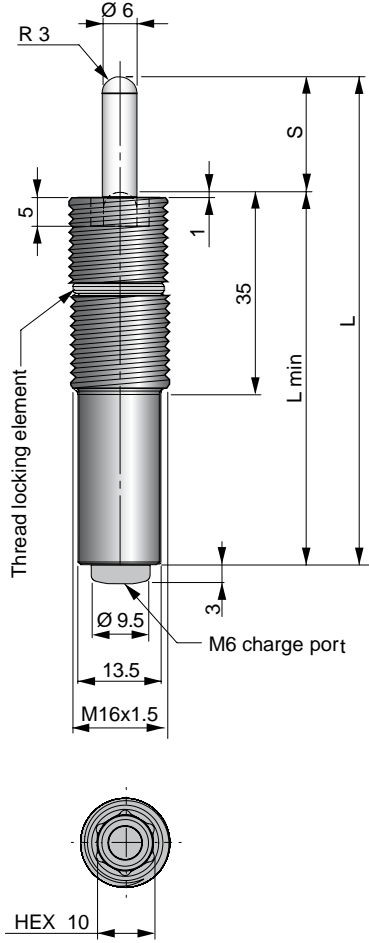

Mould Temp gas springs have been engineered to withstand higher working temperatures, like those commonly associated with plastic moulding tools. Mould Temp gas springs are compact and powerful piston rod sealed gas springs, which can be used at working temperatures up to 120°C.

Features:

- For applications up to 120°C
- Fully adjustable charge pressure
- Various mounting possibilities using our standard mounts as well as bottom threaded holes
- MT 16 and MT 24 have threaded upper cylinders for easy and adjustable mounting
- M6 gas ports that can be connected to the special high temp version of our Micro EO24™ Hose and Tube system for remote pressure control

Max. Working Temp. Interval	Max Strokes per Minute (spm)	Max Charge Pressure at 20°C (bar)	Force per Temperature		
			Spring Temp.	Initial Force (N)	End Force* (N)
0 - 80°C	20	150	80°C (20°C)	510 (420)	810 (670)
80 - 100°C	15	125	100°C (20°C)	450 (355)	720 (570)
100 - 120°C	10	115	120°C (20°C)	435 (325)	700 (520)

Order No.	S Stroke	Initial Force in N at 150 bar/+20°C	L ±0.25	L min	Gas vol. (l)	Weight (kg)
MT 16-010	10	420	65	55	0.002	0.06
MT 16-020	20		85	65	0.003	0.07
MT 16-030	30		105	75	0.003	0.07
MT 16-040	40		125	85	0.004	0.08
MT 16-050	50		145	95	0.005	0.09
MT 16-060	60		165	105	0.006	0.10
MT 16-070	70		185	115	0.007	0.11
MT 16-080	80		205	125	0.008	0.11

* = at full stroke

Basic Information

For general information see "About Gas Springs", 2.1
 Pressure medium Nitrogen
 Max. charging pressure See table above
 Min. charging pressure 25 bar (at 20°C)
 Operating temperature 0 - +120°C
 Force increase by temperature ±0.3%/°C
 Recommended max strokes/min See table above
 Max piston rod velocity 1.0 m/s
 Service life (0 to 80°C) 1'000'000 strokes
 or 100'000 strokemeters*
 Service life (80 to 120°C) 500'000 strokes
 or 50'000 strokemeters*
 Tube surface Black oxide
 Rod surface Nitrided
 Repair kit Non-repairable

Mounting Possibilities

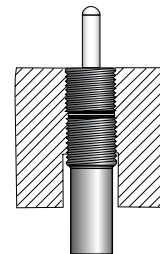

Thread Mount
 Lock nut available
 M16x1.5 503681

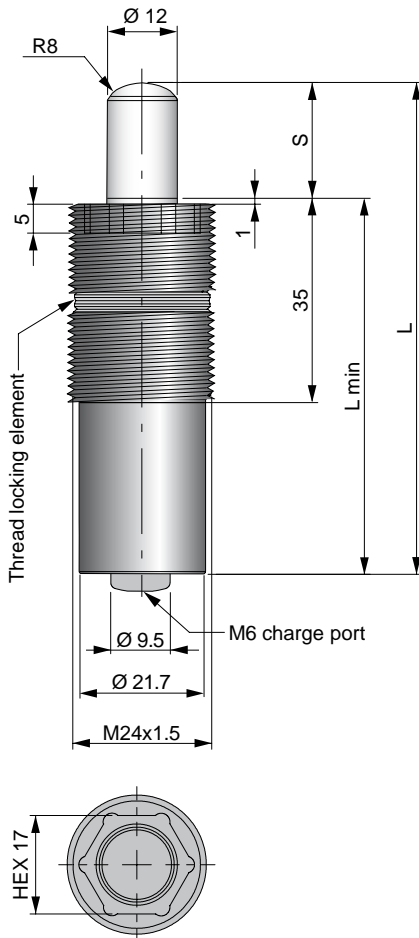

Mould Temp gas springs have been engineered to withstand higher working temperatures, like those commonly associated with plastic moulding tools. Mould Temp gas springs are compact and powerful piston rod sealed gas springs, which can be used at working temperatures up to 120°C.

Features:

- For applications up to 120°C
- Fully adjustable charge pressure
- Various mounting possibilities using our standard mounts as well as bottom threaded holes
- MT 16 and MT 24 have threaded upper cylinders for easy and adjustable mounting
- M6 gas ports can be connected to the special high temp version of our Micro EO24™ Hose and Tube system for remote pressure control

Max. Working Temp. Interval	Max Strokes per Minute (spm)	Max Charge Pressure at 20°C (bar)	Force per Temperature		
			Spring Temp.	Initial Force (N)	End Force* (N)
0 - 80°C	20	150	80°C (20°C)	2040 (1700)	3250 (2700)
80 - 100°C	15	125	100°C (20°C)	1800 (1415)	2880 (2250)
100 - 120°C	10	115	120°C (20°C)	1750 (1300)	2800 (2080)

Order No.	S Stroke	Initial Force in N at 150 bar/+20°C	L ±0.25	L min	Gas vol. (l)	Weight (kg)
MT 24-010	10	1700	65	55	0.003	0.13
MT 24-020	20		85	65	0.006	0.15
MT 24-030	30		105	75	0.008	0.17
MT 24-040	40		125	85	0.011	0.19
MT 24-050	50		145	95	0.012	0.21
MT 24-060	60		165	105	0.014	0.23
MT 24-070	70		185	115	0.017	0.25
MT 24-080	80		205	125	0.019	0.27

* = at full stroke

Basic Information

For general information see "About Gas Springs", 2.1
 Pressure medium Nitrogen
 Max. charging pressure See table above
 Min. charging pressure 25 bar (at 20°C)
 Operating temperature 0 - +120°C
 Force increase by temperature ±0.3%/°C
 Recommended max strokes/min See table above
 Max piston rod velocity 1.0 m/s
 Service life (0 to 80°C) 1'000'000 strokes
 or 100'000 strokemeters*
 Service life (80 to 120°C) 500'000 strokes
 or 50'000 strokemeters*
 Tube & rod surface Nitrided
 Repair kit Non-repairable

Mounting Possibilities

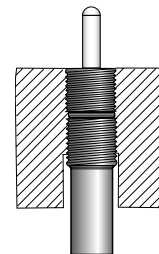

Thread Mount
 Lock nut available
 M24x1.5 503928

We reserve the right to add, delete or modify components without notification.

All dimensions are stated in mm.
 All dimensions are nominal unless tolerance is stated.

Mould Temp gas springs have been engineered to withstand higher working temperatures, like those commonly associated with plastic moulding tools. Mould Temp gas springs are compact and powerful piston rod sealed gas springs, which can be used at working temperatures up to 120°C.

Features:

- For applications up to 120°C
- Fully adjustable charge pressure
- Various mounting possibilities using our standard mounts as well as bottom threaded holes
- M6 gas ports can be connected to the special high temp version of our Micro EO24™ Hose and Tube system for remote pressure control

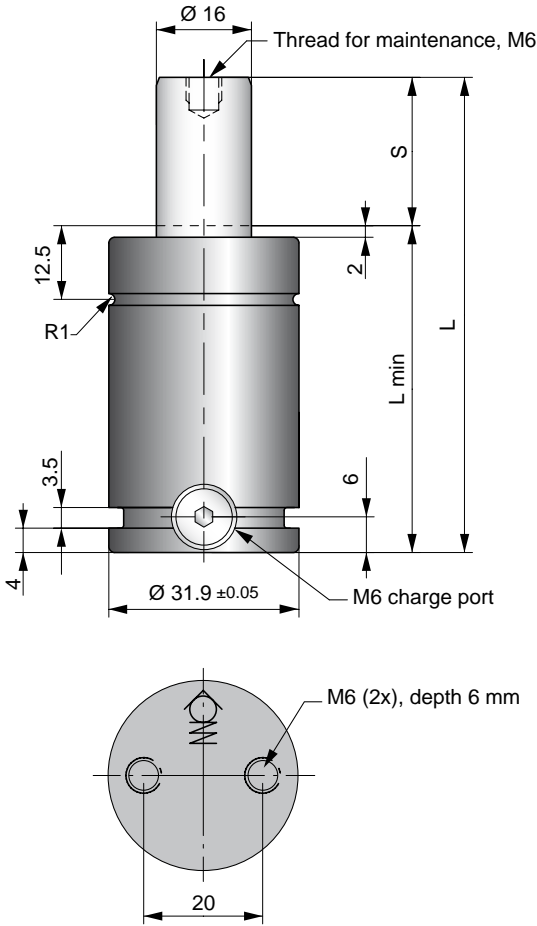

Max. Working Temp. Interval	Max Strokes per Minute (spm)	Max Charge Pressure at 20°C (bar)	Force per Temperature		
			Spring Temp.	Initial Force (N)	End Force* (N)
0 - 80°C	20	150	80°C (20°C)	3630 (3000)	5550 (4600)
80 - 100°C	15	125	100°C (20°C)	3200 (2510)	4900 (3850)
100 - 120°C	10	115	120°C (20°C)	3100 (2310)	4750 (3540)

* = at full stroke

Order No.	S Stroke	Initial Force in N at 150 bar/+20°C	L ±0.25	L min	Gas vol. (l)	Weight (kg)
MT 300-010	10	3000	50	40	0.01	0.17
MT 300-013	13		56	43	0.01	0.17
MT 300-016	16		62	46	0.01	0.19
MT 300-019	19		68	49	0.01	0.20
MT 300-025	25		80	55	0.02	0.21
MT 300-032	32		94	62	0.02	0.23
MT 300-038	38		106	68	0.03	0.25
MT 300-050	50		130	80	0.03	0.29
MT 300-063	63		156	93	0.04	0.33
MT 300-075	75		180	105	0.05	0.36
MT 300-080	80	190	110	0.05	0.38	

Basic Information

For general information see "About Gas Springs", 2.1
 Pressure medium Nitrogen
 Max. charging pressure See table above
 Min. charging pressure 25 bar (at 20°C)
 Operating temperature 0 - +120°C
 Force increase by temperature ±0.3%/°C
 Recommended max strokes/min See table above
 Max piston rod velocity 1.0 m/s
 Service life (0 to 80°C) 1'000'000 strokes
 or 100'000 strokemeters*
 Service life (80 to 120°C) 500'000 strokes
 or 50'000 strokemeters*

Tube & rod surface Nitrided
 Repair kit 3022687

Mounting Possibilities

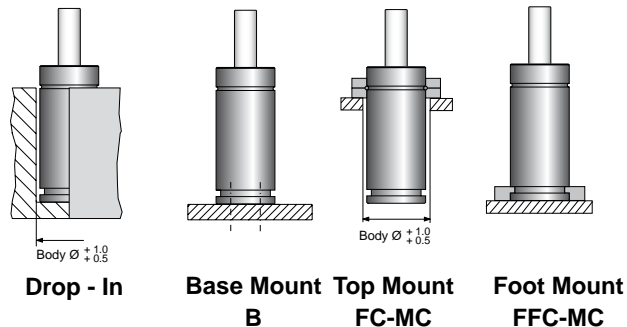

FC-MC-150
Order No. FC-MC-150

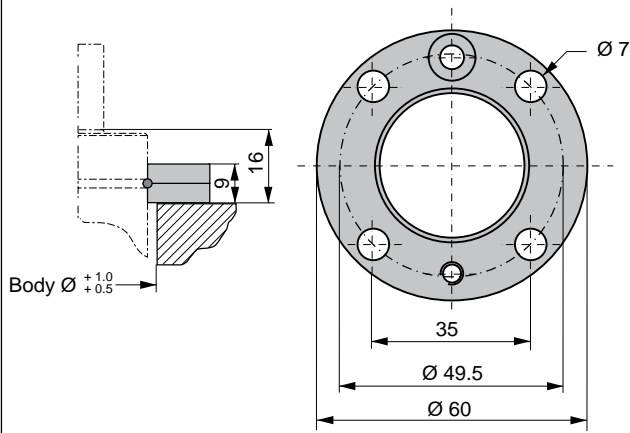

FFC-MC-150
Order No. FFC-MC-150

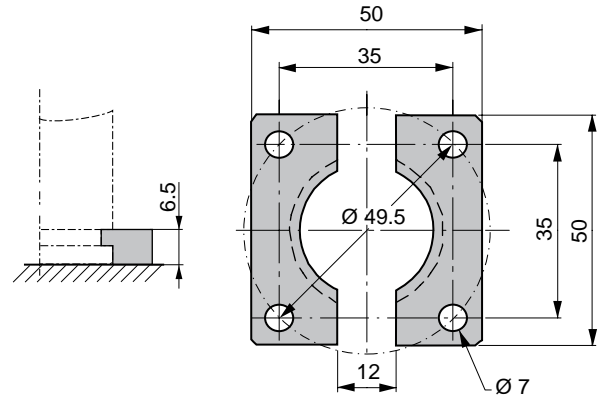

FCS-32
Order No. FCS-32

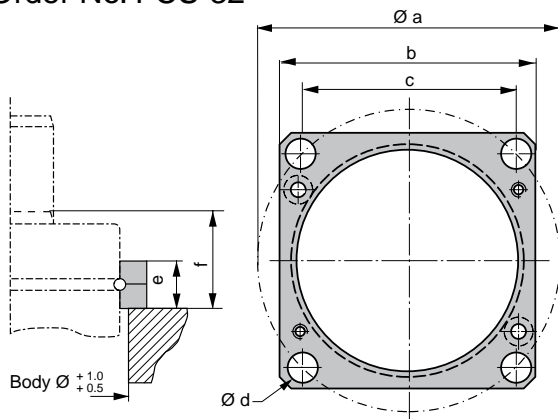

Order No.	$\varnothing a$	b	c	$\varnothing d$	e	f
FCS-32	49.5	45	35	7	9	17

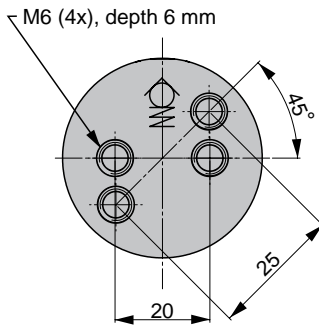
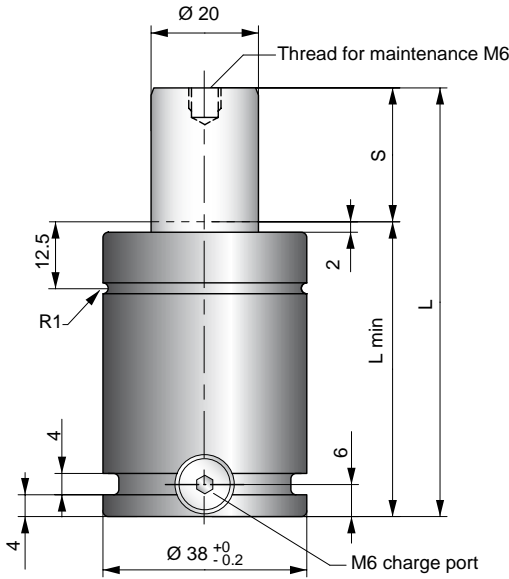

Mould Temp gas springs have been engineered to withstand higher working temperatures, like those commonly associated with plastic moulding tools. Mould Temp gas springs are compact and powerful piston rod sealed gas springs, which can be used at working temperatures up to 120°C.

Features:

- For applications up to 120°C
- Fully adjustable charge pressure
- Various mounting possibilities using our standard mounts as well as bottom threaded holes
- M6 gas ports can be connected to the special high temp version of our Micro EO24™ Hose and Tube system for remote pressure control

Max. Working Temp. Interval	Max Strokes per Minute (spm)	Max Charge Pressure at 20°C (bar)	Force per Temperature		
			Spring Temp.	Initial Force (N)	End Force* (N)
0 - 80°C	20	150	80°C (20°C)	5680 (4700)	8690 (7200)
80 - 100°C	15	125	100°C (20°C)	5000 (3930)	7650 (6010)
100 - 120°C	10	115	120°C (20°C)	4850 (3610)	7420 (5520)

* = at full stroke

Order No.	S Stroke	Initial Force in N at 150 bar/+20°C	L ±0.25	L min	Gas vol. (l)	Weight (kg)
MT 500-010	10	4700	50	40	0.01	0.25
MT 500-013	13		56	43	0.01	0.26
MT 500-016	16		62	46	0.02	0.27
MT 500-019	19		68	49	0.02	0.28
MT 500-025	25		80	55	0.03	0.31
MT 500-032	32		94	62	0.03	0.34
MT 500-038	38		106	68	0.04	0.36
MT 500-050	50		130	80	0.05	0.40
MT 500-063	63		156	93	0.06	0.45
MT 500-075	75		180	105	0.07	0.50
MT 500-080	80	190	110	0.08	0.52	

Basic Information

For general information see "About Gas Springs", 2.1
 Pressure medium Nitrogen
 Max. charging pressure See table above
 Min. charging pressure 25 bar (at 20°C)
 Operating temperature 0 - +120°C
 Force increase by temperature ±0.3%/°C
 Recommended max strokes/min See table above
 Max piston rod velocity 1.0 m/s
 Service life (0 to 80°C) 1'000'000 strokes
 or 100'000 strokemeters*
 Service life (80 to 120°C) 500'000 strokes
 or 50'000 strokemeters*
 Tube & rod surface Nitrided
 Repair kit 3022688

Mounting Possibilities

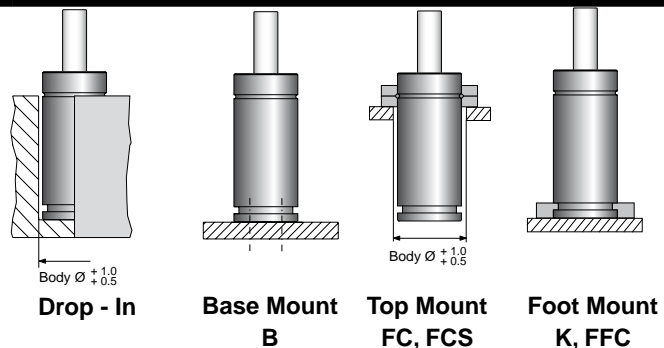

Note! For dimensions on mounting possibility K-500 refer to Chapter 3.

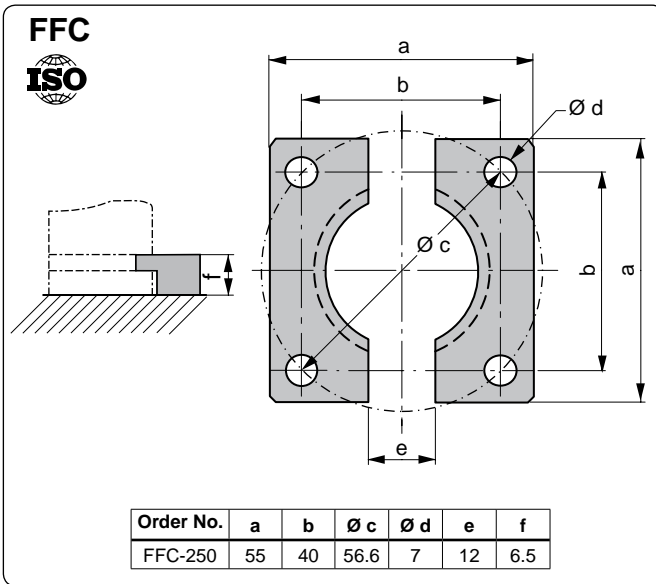
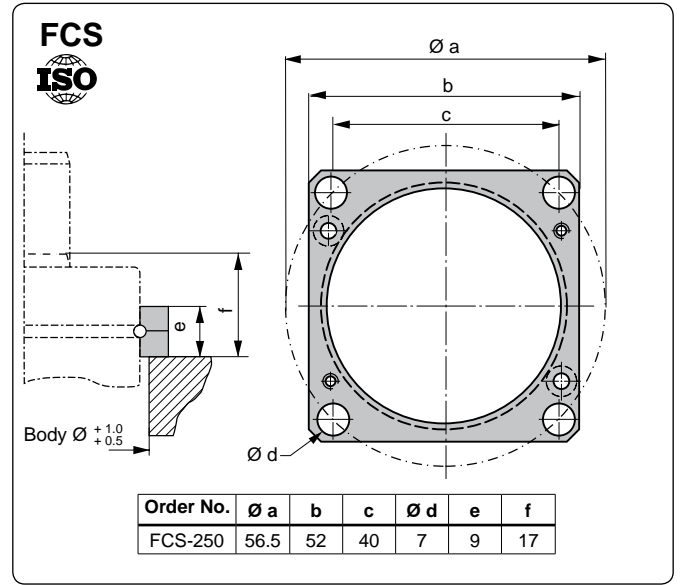
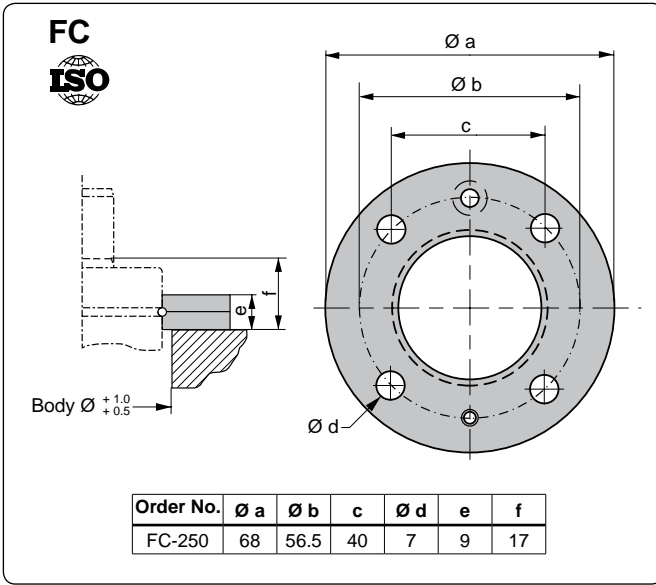

Note! For dimensions on mounting possibility K-500 refer to Chapter 3.

Mould Temp gas springs have been engineered to withstand higher working temperatures, like those commonly associated with plastic moulding tools. Mould Temp gas springs are compact and powerful piston rod sealed gas springs, which can be used at working temperatures up to 120°C.

Features:

- For applications up to 120°C
- Fully adjustable charge pressure
- Various mounting possibilities using our standard mounts as well as bottom threaded holes
- M6 gas ports can be connected to the special high temp version of our Micro EO24™ Hose and Tube system for remote pressure control

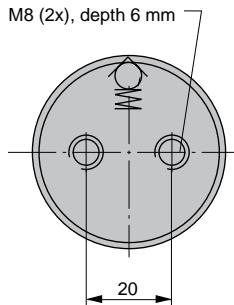
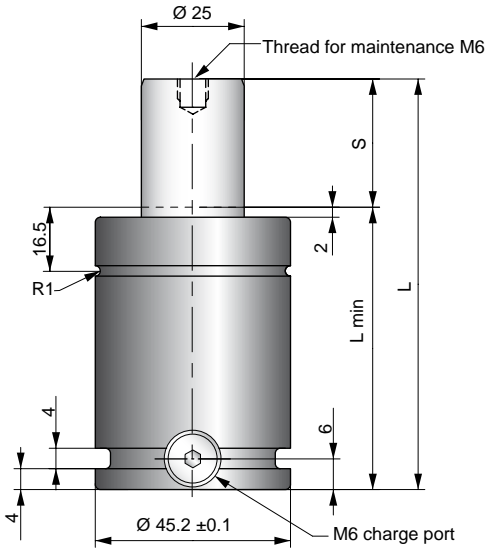

Max. Working Temp. Interval	Max Strokes per Minute (spm)	Max Charge Pressure at 20°C (bar)	Force per Temperature		
			Spring Temp.	Initial Force (N)	End Force* (N)
0 - 80°C	20	150	80°C (20°C)	8870 (7400)	14100 (11760)
80 - 100°C	15	125	100°C (20°C)	7810 (6140)	12420 (9750)
100 - 120°C	10	115	120°C (20°C)	7570 (5650)	12050 (9000)

* = at full stroke

Order No.	S Stroke	Initial Force in N at 150 bar/+20°C	L ±0.25	L min	Gas vol. (l)	Weight (kg)
MT 750-010	10	7400	52	42	0.02	0.37
MT 750-013	13		58	45	0.02	0.39
MT 750-016	16		64	48	0.03	0.41
MT 750-019	19		70	51	0.03	0.41
MT 750-025	25		82	57	0.04	0.45
MT 750-032	32		96	64	0.05	0.50
MT 750-038	38		108	70	0.05	0.53
MT 750-050	50		132	82	0.07	0.61
MT 750-063	63		158	95	0.09	0.69
MT 750-075	75		182	107	0.10	0.77
MT 750-080	80	192	112	0.11	0.80	

Basic Information

For general information see "About Gas Springs", 2.1
 Pressure medium Nitrogen
 Max. charging pressure See table above
 Min. charging pressure 25 bar (at 20°C)
 Operating temperature 0 - +120°C
 Force increase by temperature ±0.3%/°C
 Recommended max strokes/min See table above
 Max piston rod velocity 1.0 m/s
 Service life (0 to 80°C) 1'000'000 strokes
 or 100'000 strokemeters*
 Service life (80 to 120°C) 500'000 strokes
 or 50'000 strokemeters*

Tube & rod surface Nitrided
 Repair kit 3022686

Mounting Possibilities

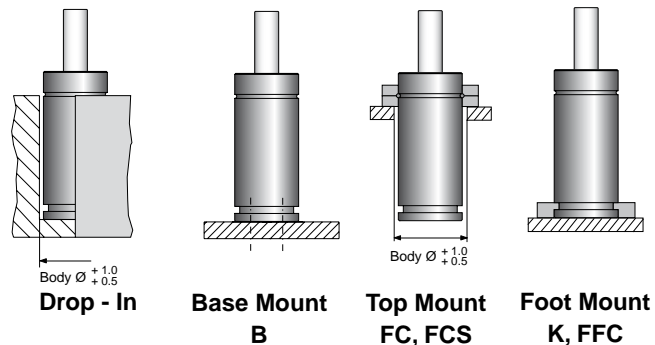

Note! For dimensions on mounting possibility K-750 refer to Chapter 3.

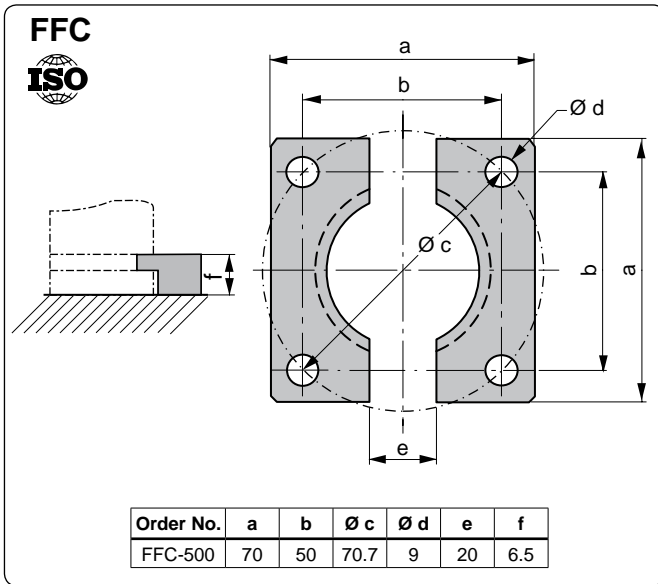
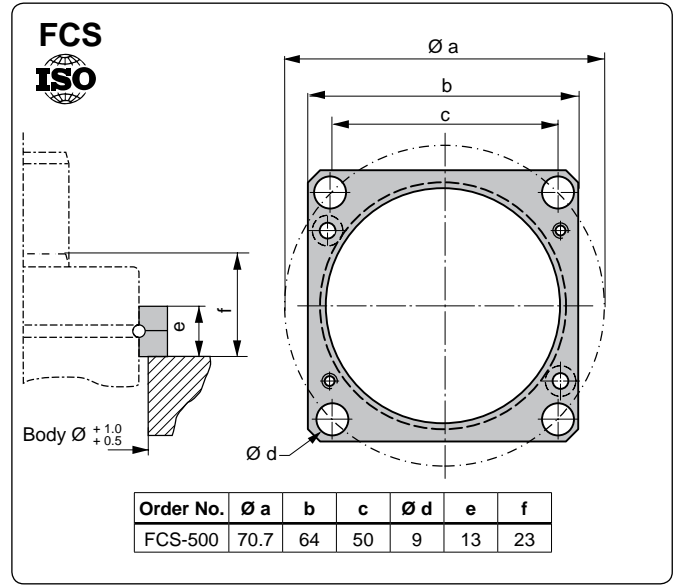
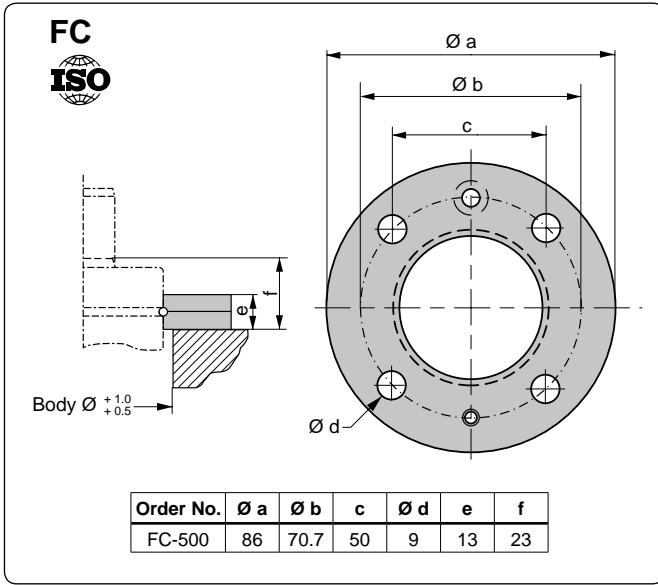

Note! For dimensions on mounting possibility K-750 refer to Chapter 3.

Mould Temp gas springs have been engineered to withstand higher working temperatures, like those commonly associated with plastic moulding tools. Mould Temp gas springs are compact and powerful piston rod sealed gas springs, which can be used at working temperatures up to 120°C.

Features:

- For applications up to 120°C
- Fully adjustable charge pressure
- Various mounting possibilities using our standard mounts as well as bottom threaded holes
- M6 gas ports can be connected to the special high temp version of our Micro EO24™ Hose and Tube system for remote pressure control

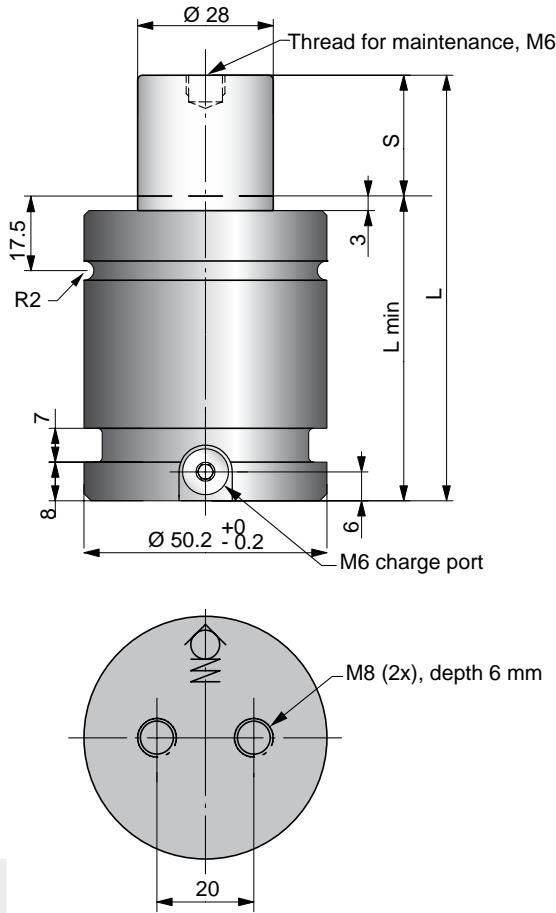

Max. Working Temp. Interval	Max Strokes per Minute (spm)	Max Charge Pressure at 20°C (bar)	Force per Temperature		
			Spring Temp.	Initial Force (N)	End Force* (N)
0 - 80°C	20	150	80°C (20°C)	11130 (9200)	17500 (14500)
80 - 100°C	15	125	100°C (20°C)	9800 (7700)	15400 (12100)
100 - 120°C	10	115	120°C (20°C)	9500 (7080)	14900 (11100)

* = at full stroke

Order No.	S Stroke	Initial Force in N at 150 bar/+20°C	L ±0.25	L min	Gas vol. (l)	Weight (kg)
MT 1000-013	13	9200	64	51	0.03	0.52
MT 1000-016	16		70	54	0.04	0.54
MT 1000-019	19		76	57	0.04	0.56
MT 1000-025	25		88	63	0.05	0.61
MT 1000-032	32		102	70	0.06	0.66
MT 1000-038	38		114	76	0.07	0.71
MT 1000-050	50		138	88	0.09	0.81
MT 1000-063	63		164	101	0.11	0.91
MT 1000-075	75		188	113	0.13	1.02
MT 1000-080	80		198	118	0.14	1.05

Basic Information

For general information see "About Gas Springs", 2.1
 Pressure medium Nitrogen
 Max. charging pressure See table above
 Min. charging pressure 25 bar (at 20°C)
 Operating temperature 0 - +120°C
 Force increase by temperature ±0.3%/°C
 Recommended max strokes/min See table above
 Max piston rod velocity 1.0 m/s
 Service life (0 to 80°C) 1'000'000 strokes
 or 100'000 strokemeters*
 Service life (80 to 120°C) 500'000 strokes
 or 50'000 strokemeters*

Tube & rod surface Nitrided
 Repair kit 3022690

Mounting Possibilities

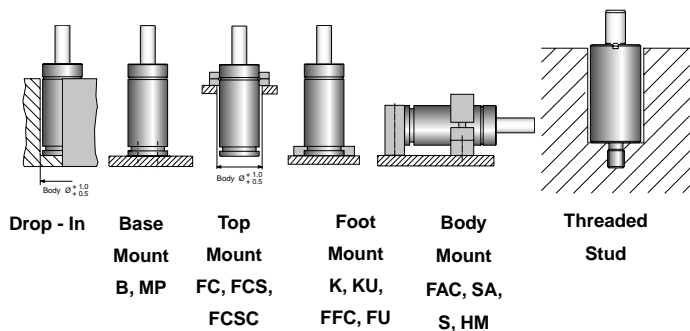

Note! For dimensions on mounting possibilities FCSC-750, K-750, KU-750, FU-750, FAC-750, SA-750 and HM-750 refer to Chapter 3.

MP
ISO

Note! Comes complete with screws to mount gas spring.

Order No.	a	b
MP-750	75	56.5

FC
ISO

Order No.	Ø a	Ø b	c	Ø d	e	f
FC-750	95	80	56.5	9	13	24

FCS
ISO

Order No.	Ø a	b	c	Ø d	e	f
FCS-750	80	70	56.5	9	13	24

FFC
ISO

Order No.	a	b	Ø c	Ø d	e	f
FFC-750	75	56.5	80	9	24	12

S
ISO

Note! Support S is designed to be used in combination with flanges mounted in the U or C groove or attachment B.

The mounting screw (M8) should be tightened with torque 25 Nm.

Order No.	Ø a	b	c	d	e	f	g	Ø h
S-750	50.4	20	40	40	130	110	10	9

Note! For dimensions on mounting possibilities FCSC-750, K-750, KU-750, FU-750, FAC-750, SA-750 and HM-750 refer to Chapter 3.

Notes

Notes

Notes



The Safer Choice

1 ABOUT THE COMPANY

2 GAS SPRINGS INCLUDING STANDARD MOUNTS

3 SPECIAL MOUNTS

4 GAS LINK SYSTEM

5 NITRO SUSPENSION

6 COUNTERBALANCE

7 SPECIAL CYLINDERS

8 SERVICE AND MAINTENANCE

9 PIERCING AND FORMING UNITS / CAMS

10 CONTROLLABLE GAS SPRINGS



For more information see our website

www.kaller.com