



# Mould Temp MT 16 to MT 1000

# Mould Temp MT 16 to MT 1000

Mould Temp gas springs have been engineered to withstand higher working temperatures, like those commonly associated with plastic moulding tools. Mould Temp gas springs are compact and powerful piston rod sealed gas springs, which can be used in temperatures up to 120°C.

## Safety Features

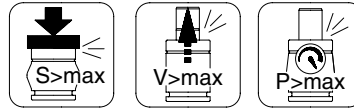

## Reliability Features

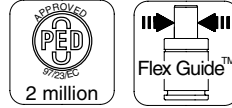

Additional information at [www.kaller.com/FAQ](http://www.kaller.com/FAQ)

## MT 300 to MT 1000 models

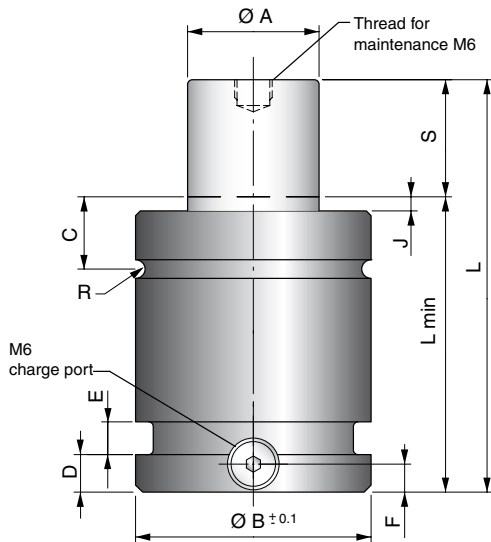

For models:  
MT 300,  
MT 750  
MT 1000

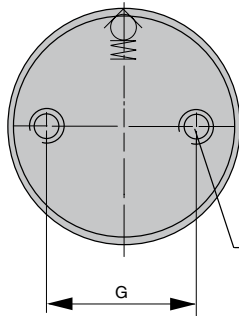

For model:  
MT 500

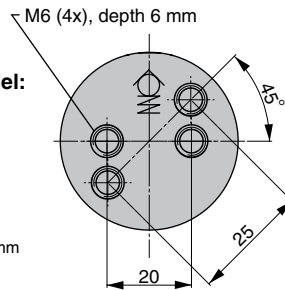

Model	Initial force in N at 150 bar/ + 20°C	Ø A	Ø B	Ø C	D	R
MT 16	420	6	M16x1.5	13.5	10	3
MT 24	1700	12	M24x1.5	21.7	17	8

Model	Initial force in N at 150 bar/ + 20°C	Ø A	Ø B	C	D	E	F	G	Ø H	J	R
MT 300	3000	16	31.9	12.5	4	3.5	6	20	M6	2	1
MT 500	4700	20	37.9	12.5	4	4		20/25	M6	2	1
MT 750	7400	25	45.2	16.5	4	4		20	M8	2	1
MT 1000	9300	28	50.2	17.5	8	7		20	M8	3	2

## Performance and Design Features:

- For applications up to 120°C
- Fully adjustable charge pressure
- Various mounting possibilities using our standard mounts as well as bottom threaded holes
- MT 16 and MT 24 have threaded upper cylinders for easy and adjustable mounting
- M6 gas ports can be connected to the special high temp version of our Micro EO24™ Hose and Tube system for remote pressure control

## MT 16 & 24 models

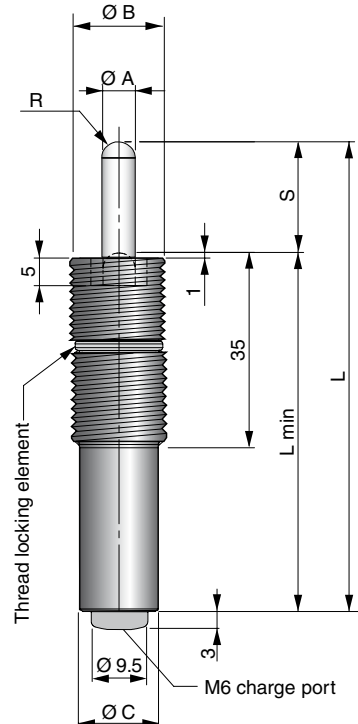
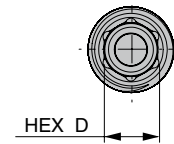

Limited Features for MT 16 and 24

# Mould Temp MT 16 to MT 1000

## Length dimensions per stroke length

Model		Stroke length							
		10	20	30	40	50	60	70	80
MT 16	L	65	85	105	125	145	165	185	205
	Lmin	55	65	75	85	95	105	115	125
MT 24	L	65	85	105	125	145	165	185	205
	Lmin	55	65	75	85	95	105	115	125

Model		Stroke length										
		10	13	16	19	25	32	38	50	63	75	80
MT 300	L	50	56	62	68	80	94	106	130	156	180	190
	Lmin	40	43	46	49	55	62	68	80	93	105	110
MT 500	L	50	56	62	68	80	94	106	130	156	180	190
	Lmin	40	43	46	49	55	62	68	80	93	105	110
MT 750	L	52	58	64	70	82	96	108	132	158	182	192
	Lmin	42	45	48	51	57	64	70	82	95	107	112
MT 1000	L	-	64	70	76	88	102	114	138	164	188	198
	Lmin	-	51	54	57	63	70	76	88	101	113	118

Maximum charge pressure and stroke frequency will depend on the operating temperature, according to the following table:

Operating temperature interval (°C)	Max strokes per minute (spm)	Max charge pressure at 20°C (bar)	Initial force (N)	Spring model					
				MT 16	MT 24	MT 300	MT 500	MT 750	MT 1000
0 - 80	20	150*	at 80°C (at 20°C)	510 (420)	2040 (1700)	3630 (3010)	5680 (4710)	8870 (7360)	11130 (9240)
80 - 100	15	125	at 100°C (at 20°C)	450 (355)	1800 (1415)	3200 (2510)	5000 (3930)	7810 (6140)	9800 (7700)
100 - 120	10	115	at 120°C (at 20°C)	435 (325)	1750 (1300)	3100 (2310)	4850 (3610)	7570 (5650)	9500 (7080)

\*Pre-charged with 150 bar unless other specified

## Basic Information

Pressure medium ..... Nitrogen  
 Max. charging pressure ..... See table above  
 Min. charging pressure ..... 25 bar (at 20°C)  
 Operating temperature ..... 0 - +120°C  
 Force increase by temperature ..... ±0.3%/°C  
 Recommended max strokes/min ..... See table above  
 Max piston rod velocity ..... 1.0 m/s  
 Service life (0 to 80°C) ..... 1'000'000 strokes  
 or ..... 100'000 strokemeters\*  
 Service life (80 to 120°C) ..... 500'000 strokes  
 or ..... 50'000 strokemeters\*  
 Repair kits ..... Available for MT 300-1000  
 Rod surface ..... Nitrided  
 Tube surface ..... Black oxide

\*For general information see "About gas springs" in main KALLER catalogue

## Mounting possibilities

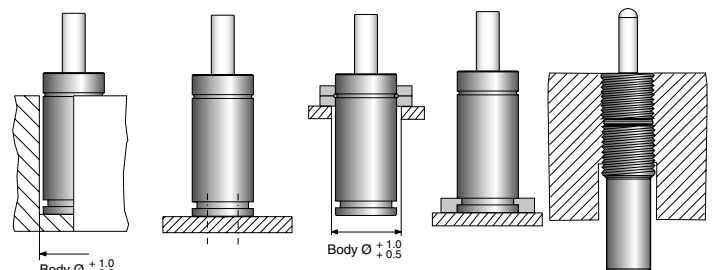

Drop - In

Base Mount

Top Mount

Foot Mount

Thread Mount  
 (Only MT 16 & 24)  
 Lock nut available  
 M16x1.5 503681  
 M24x1.5 503928

We reserve the right to add, delete or modify components without notification.

All dimensions are stated in mm.  
 All dimensions are nominal unless tolerance is stated.

# **KALLER**<sup>®</sup>

## The Safer Choice

- 1** **ABOUT THE COMPANY**

---
- 2** **GAS SPRINGS INCLUDING STANDARD MOUNTS**

---
- 3** **SPECIAL MOUNTS**

---
- 4** **GAS LINK SYSTEM**

---
- 5** **PROBLEM SOLVERS AND ACCESSORIES**

---
- 6** **LIFTERS**

---
- 7** **MACHINE AND VEHICLES**

---
- 8** **SERVICE AND MAINTENANCE**

---
- 9** **PIERCING AND FORMING UNITS / CAMS**

---
- 10** **CONTROLLABLE GAS SPRINGS**

---

